

Section 3

TRANSMITTERS

Part 1

STANDARD BROADCAST TRANSMITTERS *

H. M. SCHOLES

*Broadcast Transmitter Engineering
Technical Products Department
General Electric Company
Electronics Park
Syracuse, New York*

INTRODUCTION

Most standard broadcast transmitters in current production use the familiar design in which a final Class C RF amplifier is plate-modulated by a push-pull Class B or Class AB modulator. Of twenty-two modern transmitters described in the following pages, all but four use this design. Transmitters using other designs are all in the high-power category. One 5-kw and one 10-kw transmitter use grid modulation of the final RF amplifier. One 50-kw transmitter uses a high-efficiency linear-output amplifier, while one 50-kw transmitter uses the phase-to-amplitude modulation system.

Modern standard broadcast transmitters have been simplified to such an extent that a typical 250-watt unit employs only three tube types with a total tube complement of 10. One of the 50-kw transmitters uses only five tube types with a total tube complement of 14.

The use of semiconductors in place of tube rectifiers in the power supplies has helped to make this possible. Two of the 50-kw transmitters use semiconductor rectifiers exclusively.

Through circuit simplification and use of smaller components, transmitter dimensions have been reduced to such a degree that a modern 50-kw unit occupies little more space than that required for a 5-kw unit some years ago. This program of size reduction has been carried to the point where some manufacturers now make their high-power transmitters self-contained. Several 5- and 10-kw transmitters and one in the 50-kw class are in this category. Some manufacturers do not endorse this development, however, but maintain that operating advantages result from locating large transformers, reactors, blowers, and contactors outside the main transmitter enclosure.

The use of air-cooled tubes is found to be universal in standard broadcast transmitters in current production. Another feature found in all transmitters is the use of single-ended circuitry in RF amplifiers.

* The following manufacturers provided information and photographs for this part: Bauer Electronic Manufacturing Co., Collins Radio Company, Continental Electronics Manufacturing Company, Gates Radio Company, General Electric Company, and Radio Corporation of America.

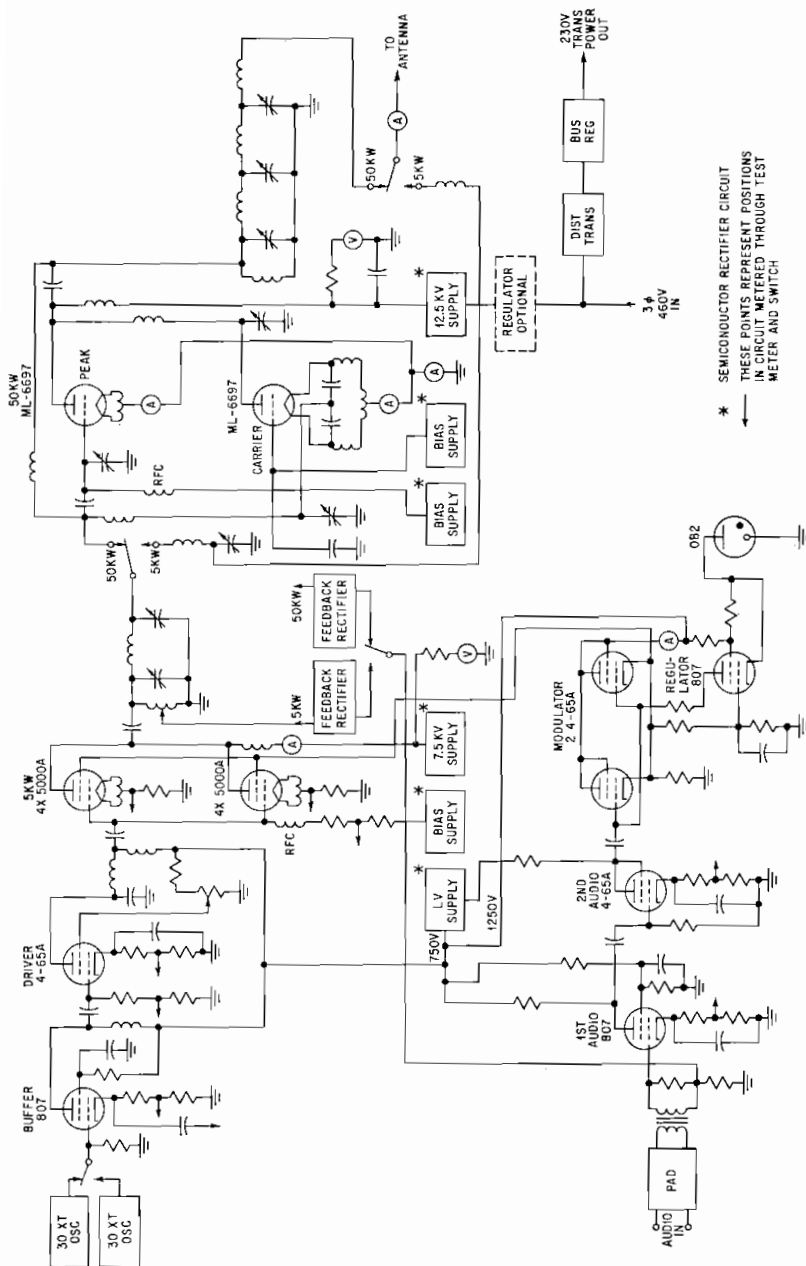

FIG. 1-1. Simplified schematic diagram—Continental type 317B 50,000-watt AM transmitter. (Courtesy of Continental Electronics Manufacturing Company.)

According to the manufacturers, all transmitters surpass FCC requirements as regards frequency stability,¹ audio-frequency response, distortion, carrier shift, and noise level.

Details of various transmitters arranged by power classes will be found in the following pages.

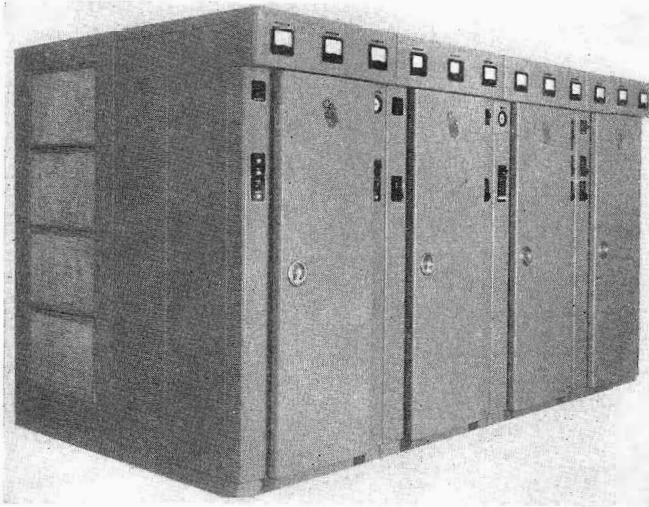

FIG. 1-2. Continental electronics type 317B 50-kw transmitter. (Courtesy of Continental Electronics Manufacturing Company.)

CONTINENTAL ELECTRONICS MANUFACTURING COMPANY TYPE 317B TRANSMITTER

This 50-kw transmitter uses a high-efficiency linear amplifier driven by a Continental Electronics type 315B 5-kw transmitter. Figure 1-1 shows the simplified schematic diagram of this transmitter, while its physical appearance is seen in Fig. 1-2.

In this circuit, modulated output of the exciter is applied to two separate amplifiers whose outputs are combined in a common load. Bias and excitation are adjusted, so that at carrier level, one amplifier (called the carrier amplifier) is operated in a nearly saturated Class B condition but the other amplifier (called the peak amplifier) is drawing essentially no plate current.

For negative excursions of modulation, the carrier amplifier, operating in a conventional Class B linear fashion, still supplies all the output power. When the positive-modulation swing starts, however, the peak amplifier begins to draw plate current and contributes power to the load. This causes the load on the carrier amplifier to decrease, thus permitting it to deliver more power. At positive-modulation crest, each amplifier develops twice the carrier power, thus supplying the fourfold carrier power required for 100 per cent modulation.

In the 317B transmitter, the grid of the carrier tube is operated at ground potential as far as the signal is concerned. The cathode of this tube is operated "above ground" and is connected to the excitation source through a phase-lag-correction network. This causes the output of the tube to have proper phase relation to the load circuit.

Some of the advantages claimed for this circuit are:

1. Neutralization not required for the carrier tube

¹ A recent NAB survey indicates that the average frequency deviation for standard broadcast stations in the United States is ± 3 cps.

2. Reduction of power requirement for the amplifier, since exciter power appears in the output

3. Reflection of antenna load back to the exciter, thus eliminating the necessity of "swamping" resistors normally used with exciters driving Class B linear amplifiers

4. Reduction of harmonic content through use of lag networks (low-pass filters) in both input and output of the carrier amplifier

The 317B transmitter is self-contained within a 12-ft by 72- by 78-in. enclosure. It uses semiconductor rectifiers in all power supplies. Additional details can be found in Table 1-1 on page 3-13.

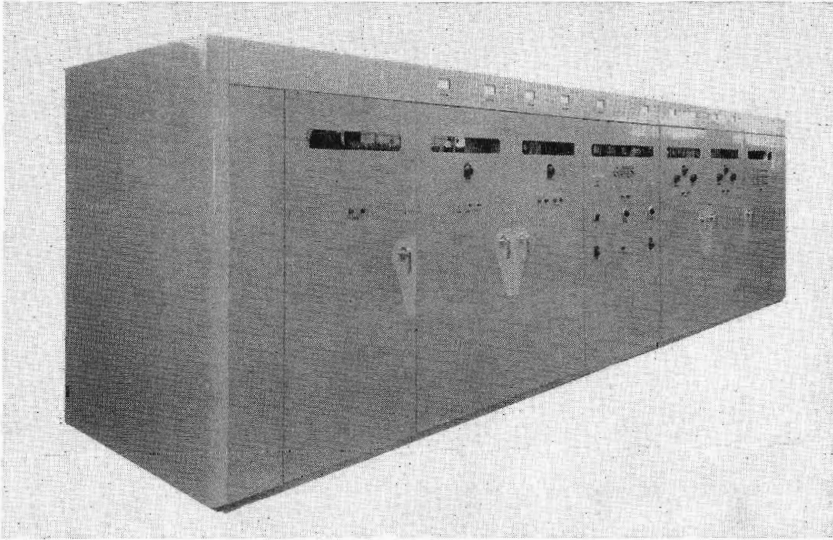

FIG. 1-4. Gates model BC-50B transmitter (50-kw). (Courtesy of Gates Radio Company.)

GATES MODEL BC-50B TRANSMITTER

The Gates Model BC-50B 50-kw transmitter is shown in simplified schematic form in Fig. 1-3.

Five stages of RF amplification are used following the crystal oscillator. The final RF amplifier is operated Class C and plate-modulated with a Class B push-pull modulator. Three stages of push-pull audio amplification precede the modulator. Audio feedback in this transmitter is obtained through a resistor-capacitor network across the primary of the modulation transformer and fed back to the grid of the first audio amplifier. Approximately 15 db of feedback is employed.

According to the manufacturer, this is physically the largest of the 50-kw transmitters. The manufacturer emphasizes its "massive" design, which provides walk-in accessibility and conservatively rated components.

A spare final RF amplifier tube and a spare modulator tube are mounted in the transmitter. Provisions are made to switch either of them into active service in case of tube failure.

Although this transmitter uses tube rectifiers throughout, the number of tube types employed has been kept to a minimum by using the same tube types in the RF and audio amplifiers.

One of the features of this transmitter is a filament voltage regulator which automatically holds the voltage on the primary of each filament transformer within $\frac{1}{2}$ of 1 per cent.

An extensive harmonic filter network has been incorporated in the BC-50B trans-

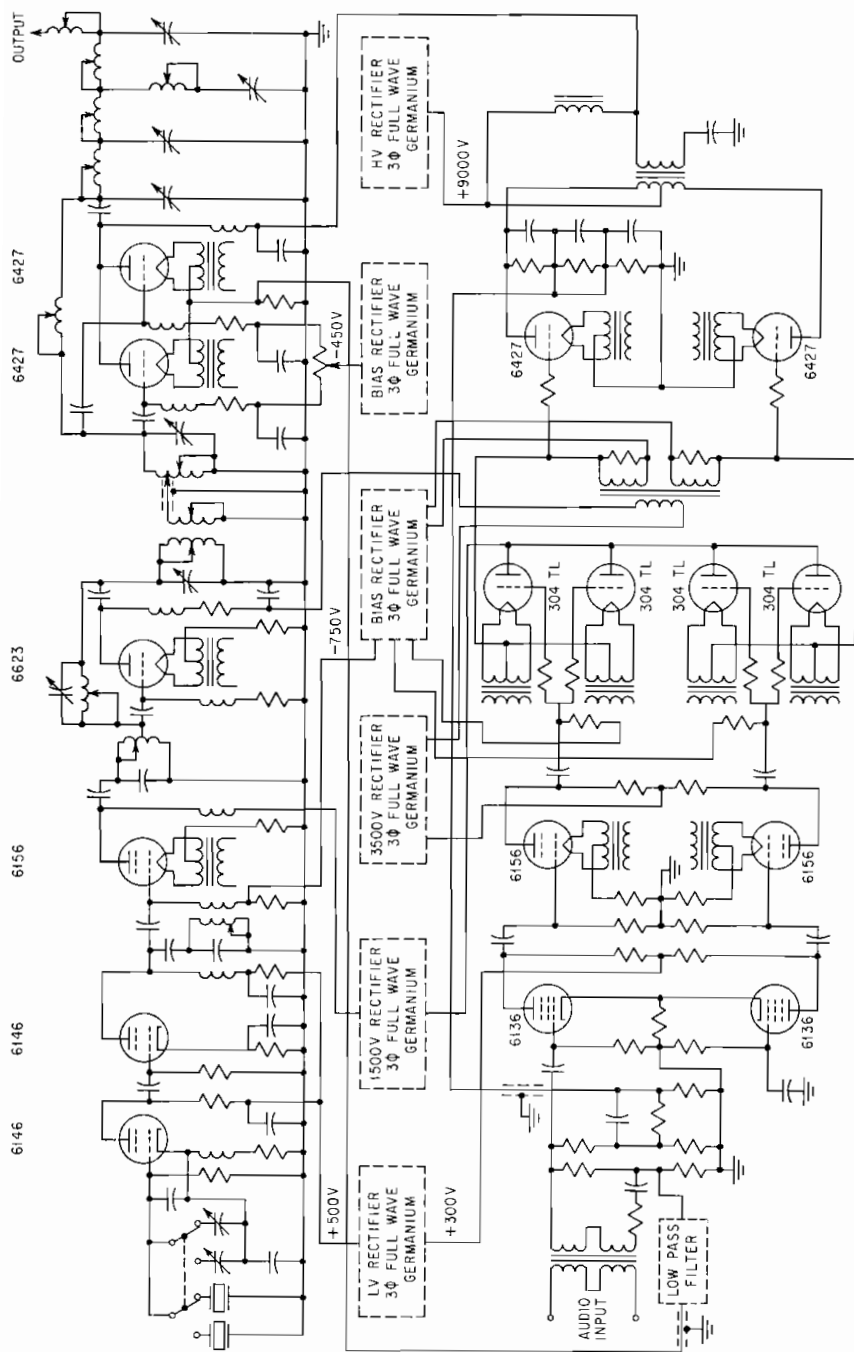

Fig. 1-5. Simplified schematic General Electric type BT-50-A transmitter. (Courtesy of General Electric Company.)

mitter which limits its harmonic output to at least 70 db below the fundamental output.

Detailed information concerning this transmitter can be found in Table 1-1.

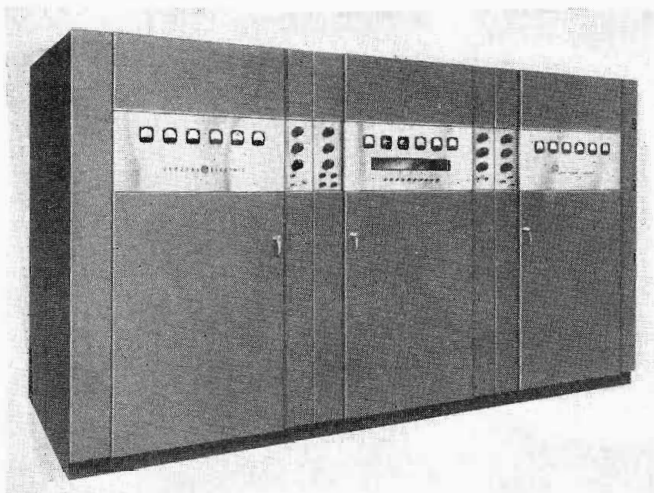

FIG. 1-6. General Electric type BT-50-A transmitter (50-kw). (Courtesy of General Electric Company.)

GENERAL ELECTRIC TYPE BT-50-A TRANSMITTER

The General Electric type BT-50-A transmitter is shown in simplified schematic form in Fig. 1-5.

Four stages of RF amplification are used following the crystal oscillator. The final RF amplifier is operated Class C and plate-modulated with a Class B push-pull modulator. A small amount of modulation is also applied to the intermediate RF amplifier in this transmitter. Two stages of push-pull audio amplification are used, together with a cathode-follower stage which drives the modulator.

Two feedback circuits are used in this transmitter. Primary feedback, which operates at higher audio frequencies, is obtained from the modulation transformer primary and fed back to the grid of the first audio amplifier. Because of very tight coupling between the two halves of the modulation-transformer primary, feedback is taken from only one-half of the primary. Approximately 10 db of feedback is supplied by this circuit above 1,000 cps.

Secondary feedback is derived from the secondary of the modulation transformer by means of a resistor in the cathode circuit of the final RF amplifier and returned to the grid of the first audio amplifier. A resistor-capacitor network in this circuit allows only frequencies below 1,000 cycles to be passed. Approximately 10 db of feedback is used at 250 cps.

All power supplies in the BT-50-A transmitter use three-phase, full-wave, germanium rectifier circuits. Included are bias supplies for the modulator and final RF amplifier and four plate supplies delivering voltages of 500, 1,500, 3,500, and 9,000 volts.

The main enclosure of this transmitter is the smallest in this power class. Plate, modulation, and distribution transformers; filter and modulation reactors; the blower; and the plate-contactor assembly are located outside this enclosure.

A completely shielded harmonic filter network is included in the output circuit of the BT-50-A transmitter. No harmonic is less than 80 db below the fundamental output.

Design of the exhaust-air system in this transmitter is such that hot air from the tubes is drawn directly out of the transmitter while incoming air is first drawn through the cubicle. This serves to keep the temperature of the transmitter components at a lower level.

Solenoid-operated vacuum switches are used for applying primary power to the high-voltage rectifier in this transmitter. This provides improved overload protection due to very fast operation of the vacuum switches.

Additional overload protection is provided by a current-limiting reactor in the primary circuit of the high-voltage rectifier.

Detailed information about this transmitter can be found in Table 1-1.

RCA TYPE BTA-50C TRANSMITTER

This 50-kw transmitter uses the phase-to-amplitude system of modulation, which RCA has termed "Ampliphase."

In this system, phase-modulated RF is applied at low levels to two amplifier chains in such a manner that when the phase is advancing in one chain, it is retarding in

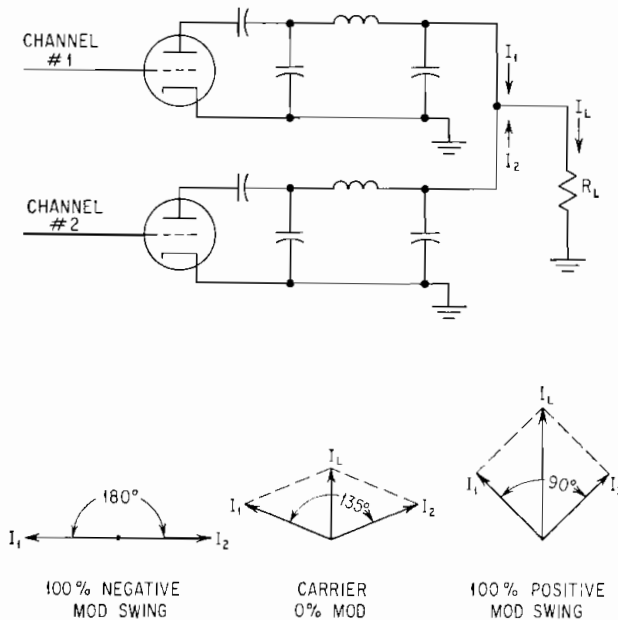

FIG. 1-7. Simplified schematic of output stage and vector diagrams illustrating "ampliphase" system.

the other. Resultant outputs of the two chains are combined in the load to produce amplitude modulation.

Referring to vector diagrams of Fig. 1-7, at carrier level (zero modulation), there is a 135° phase difference between the output currents I_1 and I_2 of the two amplifier channels, which combine to produce load current I_L . At 100 per cent negative modulation swing I_1 has advanced $22\frac{1}{2}^\circ$ and I_2 has retarded $22\frac{1}{2}^\circ$, making the phase difference between them 180° , thus causing the amplitude of I_L to drop to zero.

At 100 per cent positive modulation swing, I_1 has retarded $22\frac{1}{2}^\circ$ in phase from the carrier condition and I_2 has advanced $22\frac{1}{2}^\circ$. This makes their phase difference only 90° , with a resulting increase in the amplitude of I_L to twice the carrier level. Thus,

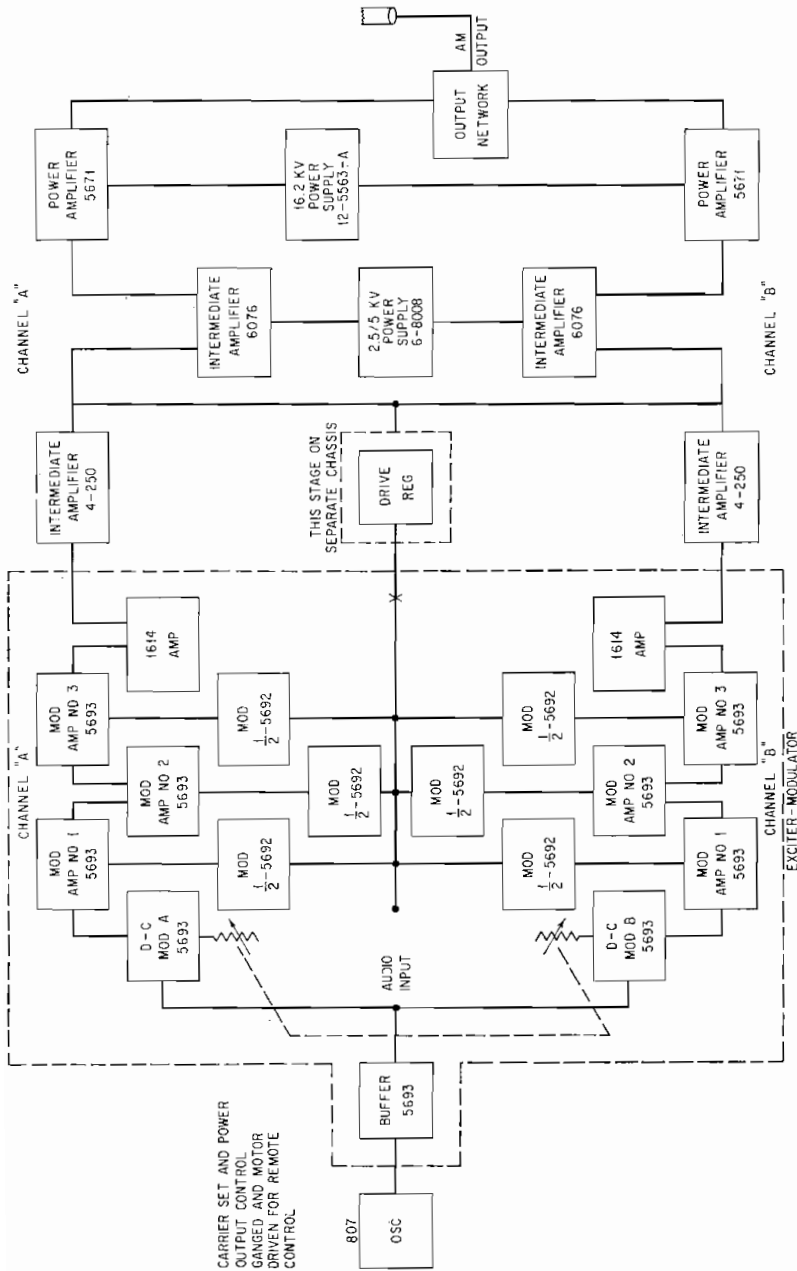

FIG. 1-8. Block diagram of RCA type BTA-50G transmitter (50-kw). (Courtesy of Radio Corporation of America.)

conditions necessary for 100 per cent amplitude modulation are achieved by shifting the phase angles of I_1 and I_2 plus and minus $22\frac{1}{2}^\circ$.

As shown in the block diagram of Fig. 1-8, the oscillator is followed by a buffer amplifier, with two outputs to feed the two amplifier chains. This buffer amplifier has a push-pull output tank circuit, which provides excitation voltages, with a phase difference of 180° for the two separate RF channels. The first stage in each channel is an adjustable phase-shift amplifier capable of shifting the phase of its output voltage plus or minus 25° . These amplifiers are normally adjusted to produce the 135° phase difference between the two channels required for carrier-level condition.

However, the phase-shift controls on the two amplifiers are mechanically connected in such a way that they can be varied simultaneously to provide a convenient control of carrier level.

Following the adjustable phase-shift amplifier in each channel are three modulated amplifier stages in which the phase is shifted by the audio signal. Each of these stages is capable of a maximum phase excursion of plus and minus $7\frac{1}{2}^\circ$. When three stages are used in cascade, the $22\frac{1}{2}^\circ$ phase excursion required for 100 per cent modulation is achieved.

Following the modulated amplifiers in each channel is a conventional amplifier which provides approximately 5 watts of RF power to excite the 4-250 stage which in turn drives the intermediate amplifier using a type 6076 tetrode. The output amplifier in each channel uses a type 5671 triode.

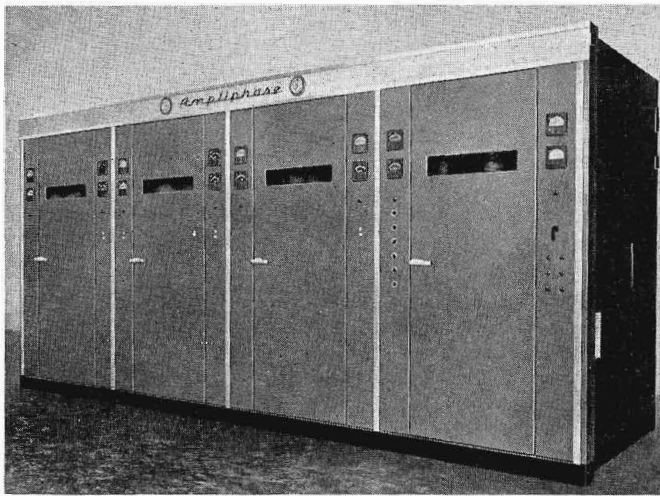

FIG. 1-9. RCA type BTA-50G transmitter (50-kw). (Courtesy of Radio Corporation of America.)

Because of the shifting phase relationship between the two output tubes, the load impedance into which they work varies widely during the modulation cycle. In order to maintain reasonably constant efficiency over the modulation cycle, it has been found desirable to vary the excitation to the output tubes with modulation. In the BTA-50G transmitter, this is accomplished by applying a degree of grid modulation to the type 6076 intermediate amplifiers.

The modulator consists of three type 807 tubes in a cathode-follower circuit. A three-stage audio amplifier precedes the modulator. The modulator and its associated audio amplifier are called the drive regulator in the BTA-50G transmitter. Approximately 90 per cent amplitude modulation of the excitation is used for 100 per cent modulation of the output.

A small amount of over-all feedback is used in this transmitter by rectifying a sample of the amplitude-modulated output and applying it in phase opposition to the incoming audio.

A completely shielded, multielement harmonic filter network has been incorporated in this transmitter to limit its harmonic output to a value at least 83 db below the fundamental output.

Additional details concerning this transmitter can be found in Table 1-1.

Table 1-1. Specifications for 50-kw Transmitters °

	Continental Electronics 317B	Gates BC-50B	General Electric BT-50-A	RCA BTA-50G
Physical data:				
Width, in.	12 ft	22 ft 6 in.	13 ft 6 in.	15 ft 1 ½ in.
Depth, in.	72	64	54	63
Height, in.	78	78	84	84
Approx. wt., lb.	12,000	25,070	13,000	12,000
Input supply:				
Voltage.	460	460	480, 2,400, 4,160	460
Phase.	3	3	3	3
Frequency, cps.	50 or 60	50 or 60	50 or 60	50 or 60
AF input level, dbm.	+10	+10	+10	+10
AF input, ohms.	150/600	150/600	150/600	150/600
Load impact, ohms.	50 or as specified	40-250	50-230	50 (nominal)
Frequency range, kc.	535-1,620	540-1,600	535-1,620	535-1,620
Max. output, kw.	53.0	53.0	53.0	53.0
External equipment.	Self-con- tained	Contacto- r cabinet Blower 4 trans- formers 2 reactors	Plate contacto- r 5 trans- formers Blower 3 reactors ΔY switch	2 circuit breakers ΔY switch 6 trans- formers 2 regulators

* The above information was supplied by the manufacturers.

5- AND 10-KW TRANSMITTERS

Most manufacturers produce only one transmitter in this power range with provisions to modify it for either 5- or 10-kw operation.

All but two of the transmitters in these power classes use a Class C final RF amplifier, which is plate-modulated by a Class B or Class AB push-pull modulator. Tetrodes are used in both the final RF and modulator stages in most units, although one manufacturer uses triodes. One manufacturer uses plate modulation of the intermediate RF amplifier as well as the final RF amplifier.

The Continental Electronics 5- to 10-kw transmitter differs from the others in that it uses screen-grid modulation of the final RF amplifier. The modulator in this case is connected as a cathode follower.

Five of the 11 transmitters in the 5- to 10-kw class are entirely self-contained.

All the 5-kw transmitters are provided with 1-kw power cutback facilities for stations using this lower nighttime power.

Tables 1-2, 1-3, 1-4 give detailed specifications of the 5- and 10-kw transmitters. Simplified schematic diagrams and photographs of typical units are shown in Figs. 1-10 through 1-16.

Table 1-2. Specifications for 10,000-watt Transmitters *

	Collins 21M	Gates BC-10P	General Electric BT-73-A	RCA BTA-10H
Tubes used:				
Oscillator.....	6AU6	12BY7A	6146	807(2)
1st RF amplifier.....	6SJ7	12BY7A	6146	807(2)
2d RF amplifier.....	807	6146	4-250A(2)	833A
3d RF amplifier.....	4-125A(2)	4-250A		
Final RF amplifier.....	3X2500A3(2)	3X2500F3(2)	3X2500F3(2)	5762(3)
1st AF amplifier.....	6SJ7(2)	6SN7	5814A	807(2)
2d AF Amplifier.....	4-125A(2)	6BG6(2)	4-125A(2)	828(2)
3d AF amplifier.....		652S(4)		813(4)
Modulator.....	3X3000A1(2)	3X2500F3(2)	3X3000F1(2)	5762(2)
Bias rectifier 1.....	5U4G	6W4(2)	5R4GY	Selenium
Bias rectifier 2.....	866A(2)	5R4GYA(2)	866(2)	
Low-voltage rectifier Intermediate Rectifier.....	866A(2)	5R4GYA	5R4GY(2)	8008(4)
High-voltage Rectifier.....	872A(2)	5R4GYA(2)		
	575A(6)	673(6)	673(6)	5563A(4)
Physical data:				
Width, in.....	105 ¼	73 ½	66	130
Depth, in.....	28	39 ½	21 ½	32 ½
Height, in.....	76	78	83	84
Approx. weight, lb..	3,000	2,650	4,500	5,500
Input supply:				
Voltage.....	208/230	230	208/230	208/230
Phase.....	3	3	3	3
Frequency, cps.....	50 or 60	50 or 60	60	50 or 60
AF input level, dbm..	+10	0	+10	+10
AF input, ohms.....	150/600	150/600	150/600	150/600
Load imp., ohms.....	40-600	40-270	50-230	40-250
Frequency range, kc..	540-1600	535-2000	540-1600	535-1620
Max. output, watts...	10,600	10,600	10,600	10,600
Miscellaneous data...	Plate trans- former external	Self-con- tained	1 transformer 2 Reactors • external	1 trans- former external Bi-level modu- lation

* The above information was supplied by the manufacturers.

Table 1-3. Specifications for Continental Electronics 5- and 10-kw Transmitters °

	Type 315B	Type 316B
Tubes used:		
Oscillator.....	6AG7(2)	6AG7(2)
1st RF amplifier.....	807	807
2d RF amplifier.....	4-65A	4-65A
Final RF amplifier.....	4X5000A(2)	4X5000A(3)
1st AF amplifier.....	807	807
2d AF amplifier.....	4-65A	4-65A
Modulator.....	4-65A(2)	4-65A(3)
Bias rectifier.....	Selenium	Selenium
Low-voltage rectifier.....	Selenium	Selenium
High-voltage rectifier.....	Selenium	Selenium
Two-oscillator regulator.....	0B2(2)	0B2(2)
Modulator regulator.....	807	807
Voltage reference.....	0B2	0B2
Feedback rectifier.....	6X5	6X5
Physical data:		
Width, in.....	72	72
Depth, in.....	36	36
Height, in.....	78	78
Approx. weight, lb.....	5,000	5,300
Input supply:		
Voltage.....	208/230	208/230
Phase.....	3 (open Δ)	3
Frequency, cps.....	60 (50 avail.)	60 (50 avail.)
AF input level, dbm.....	+10	+10
AF input impedance, ohms.....	150/600	150/600
Output impedance, ohms.....	50 (or as specified)	50 (or as specified)
Frequency range, kc.....	535-1,620	535-1,620
Max. output, watts.....	5,500	10,600
Miscellaneous data.....	Self-contained	Self-contained

*The above information was supplied by the manufacturer.

Note: These transmitters are not listed with the other 5- and 10-kw transmitters because of their different tube classifications resulting from the use of screen-grid modulation of the final RF amplifier.

Table 1-4. Specifications for 5,000-watt Transmitters °

	Collins 21E	Fritz Bauer FB-5000C	Gates BC-5P	General Electric BT-72-A	RCA BTA-5H
Tubes used:					
Oscillator.....	6AU6	6AG7	6AG7	6146	807(2)
1st RF amplifier.....	6SJ7	6AG7(2)	6146	6146	807(2)
2d RF amplifier.....	807	813	4-250A	4-250A	833A
3d RF amplifier.....	4-125A(2)				
Final RF amplifier....	3X2500A3	3X2500F3	3X2500F3	3X2500F3	5762(2)
1st AF amplifier.....	6SJ7(2)	807(2)	6SN7	5814A	807(2)
2d AF amplifier.....	4-125A(2)	845(2)	6SN7	4-125A(2)	828(2)
3d AF amplifier.....			6550(4)		813(2)
Modulator.....	3X3000A1 (2)	3X2500F3 (2)	3X2500F3 (2)	3X3000F1 (2)	5762(2)
Bias rectifier 1.....	5U4G	5R4GY(2)	5R4GY	5R4GY	Selenium
Bias rectifier 2.....	866A(2)		6W4(2)	866(2)	
Low-voltage rectifier..	866A(2)	5R4GY	5R4GY	5R4GY(2)	8008(4)
Intermed. rectifier....	872A(2)		5R4GY(2)		
High-voltage rectifier..	575A(6)	8008(6)	8008(6)	8008(6)	5563A(4)
Physical data:					
Width, in.....	105 1/4	90	73 1/2	66	130
Depth, in.....	28	36	39 1/2	21 1/2	32 1/2
Height, in.....	76	72	78	83	84
Approx. weight, lb....	2,700	3,000	2,186	4,500	5,300
Input supply:					
Voltage.....	208/230	230	230	208/230	208/230
Phase.....	3	3	3	3	3
Frequency, cps.....	50 or 60	60	50 or 60	60	50 or 60
AF input level, dbm....	+10	+10	-5	+10	+10
AF input, ohms.....	150/600	500/600	150/600	600	150/600
Load impact, ohms.....	40-600	50-250	40-270	50-230	40-250
Frequency range, kc....	540-1,600	540-1,620	535-2,000	540-1,600	535-1,620
Max. output, watts....	5,500	6,000	5,600	5,500	5,500
1,000-watt power cut- back.....	Yes	Yes	Yes	Yes	With kit
Miscellaneous data.....	Plate trans- former external	Self-con- tained	Self-con- tained	1 trans- former 2 reactors external	Plate trans- former external Bi-level modula- tion used

* The above information was supplied by the manufacturers.

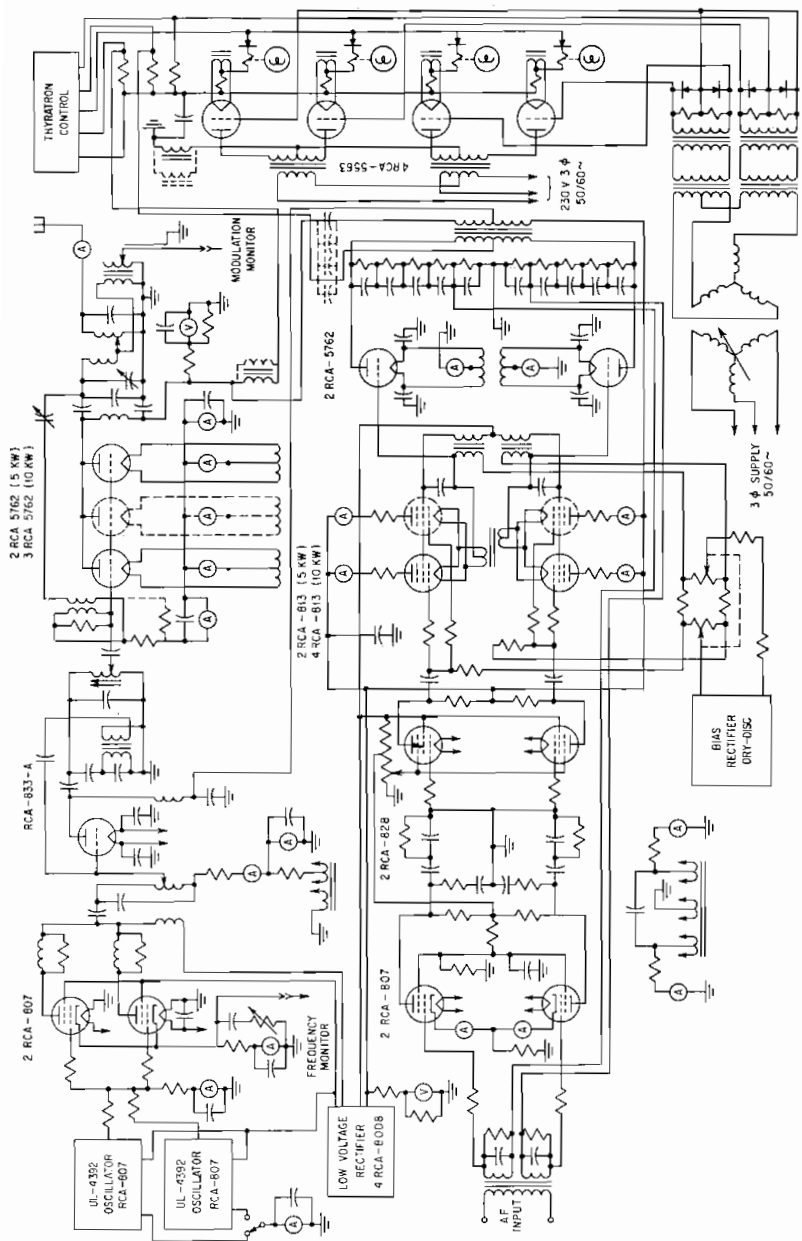

Fig. 1-10. Simplified schematic RCA type BTA-5H (5-kw) and type BTA-10H (10-kw) transmitters. The dotted lines indicate changes required for 10-kw operation. (Courtesy of Radio Corporation of America.)

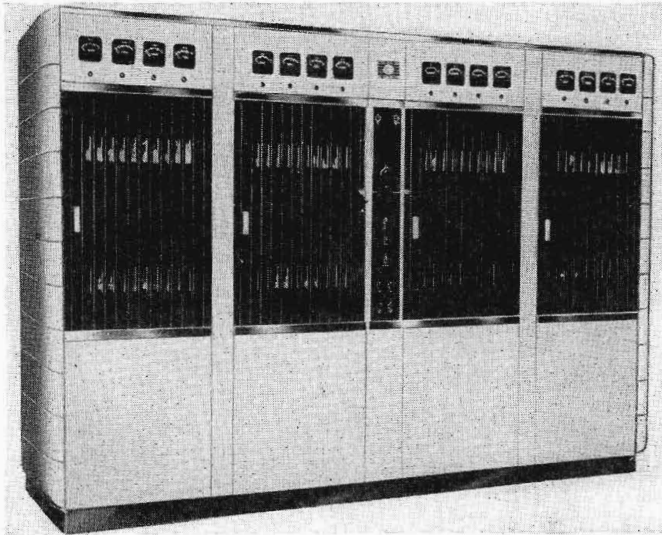

FIG. 1-11. RCA type BTA-5H/BTA-10H transmitter (5- or 10-kw). (Courtesy of Radio Corporation of America.)

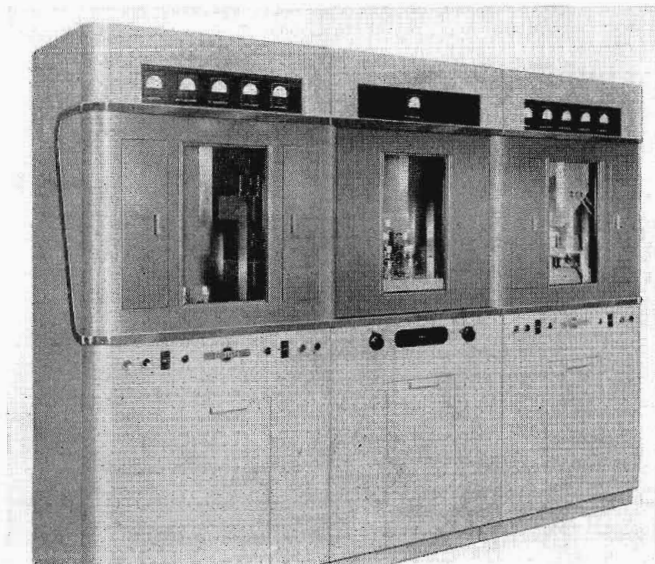

FIG. 1-12. Collins 21E/21M transmitter (5- to 10-kw). (Courtesy of Collins Radio Company.)



FIG. 1-13. Continental Electronics type 315B/316B 5- to 10-kw transmitter. (Courtesy of Continental Electronics Manufacturing Company.)

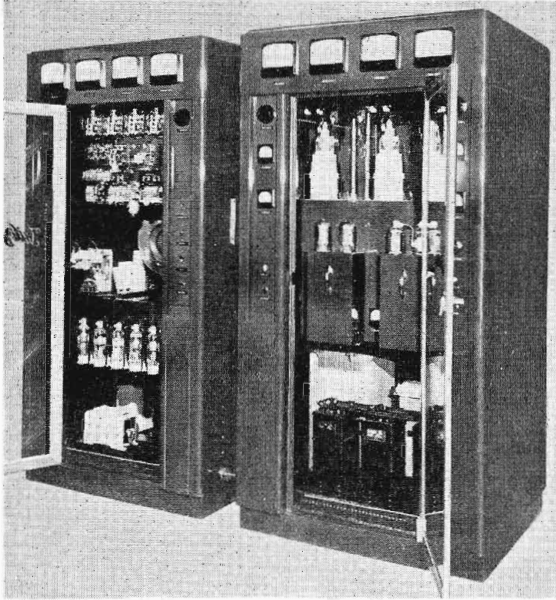

FIG. 1-15. Fritz Bauer FB-5000-C transmitter (5-kw). (Courtesy of Bauer Electronic Manufacturing Company.)

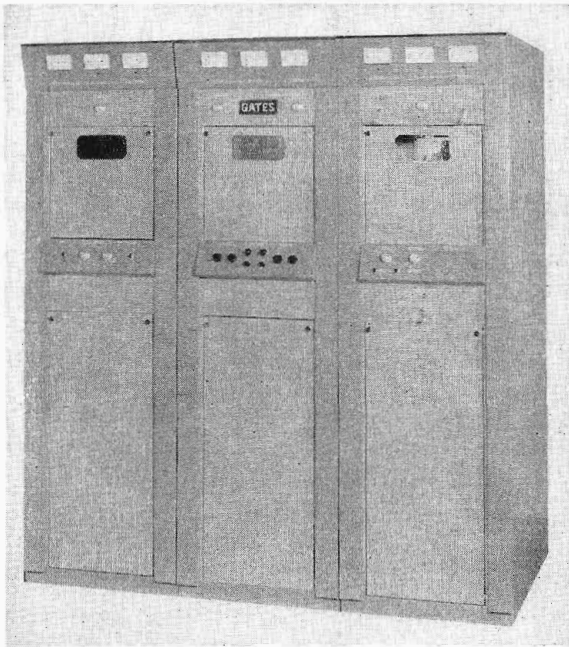

FIG. 1-16. Gates model BC-5P transmitter (5-kw). (Courtesy of Gates Radio Company.)

250- AND 1,000-WATT TRANSMITTERS

Since there are so many points of similarity in the 250- and 1,000-watt transmitters, they can be described together. Some manufacturers, in fact, use identical cabinets, control circuits, and low-level stages for their 250- and 1,000-watt units. Required changes are made in the final RF and modulator stages and in the capacity of the high-voltage power supply.

In both power classes, the transmitters have been designed for simplicity and economy. Each uses a crystal oscillator, followed by one or two intermediate RF amplifiers, and a Class C final RF amplifier which is plate-modulated by a push-pull Class B or Class AB modulator. One or two stages of push-pull audio amplification precede the modulator. One manufacturer uses modulation in the intermediate RF amplifier as well as in the final RF amplifier.

Three power supplies are used for bias, low-voltage plate, and high-voltage plate, respectively. Only one manufacturer has adopted the use of semiconductor rectifiers in power supplies.

In all cases, these transmitters are self-contained, but there is considerable variation in size.

Several manufacturers produce 500-watt transmitters which are slightly modified versions of their 1,000-watt units. Changes are so minor that the 500-watt models will not be described in detail in this report.

Following are detailed specifications of the 250- and 1,000-watt transmitters, together with simplified schematic diagrams and photographs of typical units.

Table 1-5. Specifications for 1,000-watt Transmitters *

	Collins 20V-2	Fritz Bauer FB-1000J	Gates RC-1T	RCA BTA-1R
Tubes used:				
Oscillator	6AU6	6AG7	12BY7A	6AK5
1st RF amplifier	6SJ7	807	12BY7A	5763
2d RF amplifier	807	807	6BG6G(2)	6146
Final RF amplifier	4-400A(2)	4-400A(2)	833A(2)	4-400A(2)
1st AF amplifier	6SJ7(2)	807(2)	6BG6G(2)	2E26(2)
2d AF amplifier	807	807	6BG6G(2)	807
Modulator	4-400A(2)	4-400A(2)	833A(2)	4-400A(2)
Bias rectifier	5U4G	5R4GY	5R4GY	Selenium
Low-voltage rectifier	866A(2)	5R4GY	866A(2)	Selenium
High-voltage rectifier	872A(2)	800S(2)	800S(2)	800S(2)
Physical data:				
Width, in.	38	34	36	34
Depth, in.	27	23	32	32 1/2
Height, in.	76	78	78	84
Weight, lb.	1,150	700	800	1,700
Input supply:				
Voltage	208/230	230	230	208/240
Phase	1	1	1	1
Frequency, cps.	50 or 60	60	50 or 60	50 or 60
AF input level, dbm	+10	+10	+12	+10
AF input, ohms	150/600	500/600	150/600	150/600
Load impact, ohms	40-600	50-250	50-70	40-250
Frequency range, kc.	540-1,600	540-1,620	540-2,000	535-1,620
Max. output, watts	1,100	1,100	1,100	1,100
Miscellaneous data		Dummy antenna supplied	Dummy antenna supplied	Bi-level modula- tion used

* The above information was supplied by the manufacturers.

Table 1-6. Specifications for 250-watt Transmitters °

	Collins 300J-2	Gates BC-250-GY	RCA BTA-250M
Tubes used:			
Oscillator.....	6AU6	807	807
1st RF amplifier.....	6SJ7	813	807
2d RF amplifier.....	807		
Final RF amplifier.....	4-125A(2)	810(2)	813(2)
1st AF amplifier.....	6SJ7(2)	6L6(2)	807(2)
Modulator.....	4-125A(2)	810(2)	813(2)
Bias rectifier.....	5U4G	5V4	Selenium
Low-voltage rectifier.....	866A(2)	5V4	Selenium
High-voltage rectifier.....	872A(2)	8008(2)	866A(2)
Physical data:			
Width, in.....	38	40	28
Depth, in.....	27	33	20 ½
Height, in.....	76	78	84 ⅝
Weight, lb.....	900	900	600
Input supply:			
Voltage.....	208/230	230	110/125
Phase.....	1	1	1
Frequency, cps.....	50 or 60	60	50 or 60
AF input level, dbm.....	+10	+14	+10
AF input, ohms.....	600/150	600	150/600
Output load, ohms.....	40-600	30-300	20-250
Frequency range, kc.....	540-1,600	540-1,600	535-1,620
Max. output, watts.....	275	280	275
Miscellaneous data.....	100-watt power cutback	Bi-level modula- tion used

* The above information was supplied by the manufacturers.

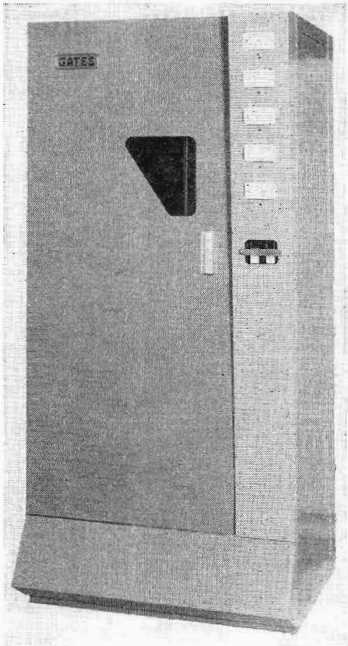

FIG. 1-18. Gates BC-1T (1,000-watt) AM broadcast transmitter. (Courtesy of Gates Radio Company.)

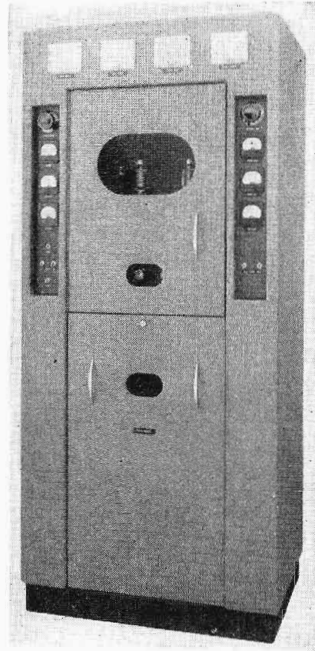

FIG. 1-19. Fritz Bauer FB-1000J (1,000-watt) AM broadcast transmitter. (Courtesy of Bauer Electronic Manufacturing Company.)

FIG. 1-20. RCA type BTA-1R (1,000-watt) AM broadcast transmitter. (Courtesy of Radio Corporation of America.)



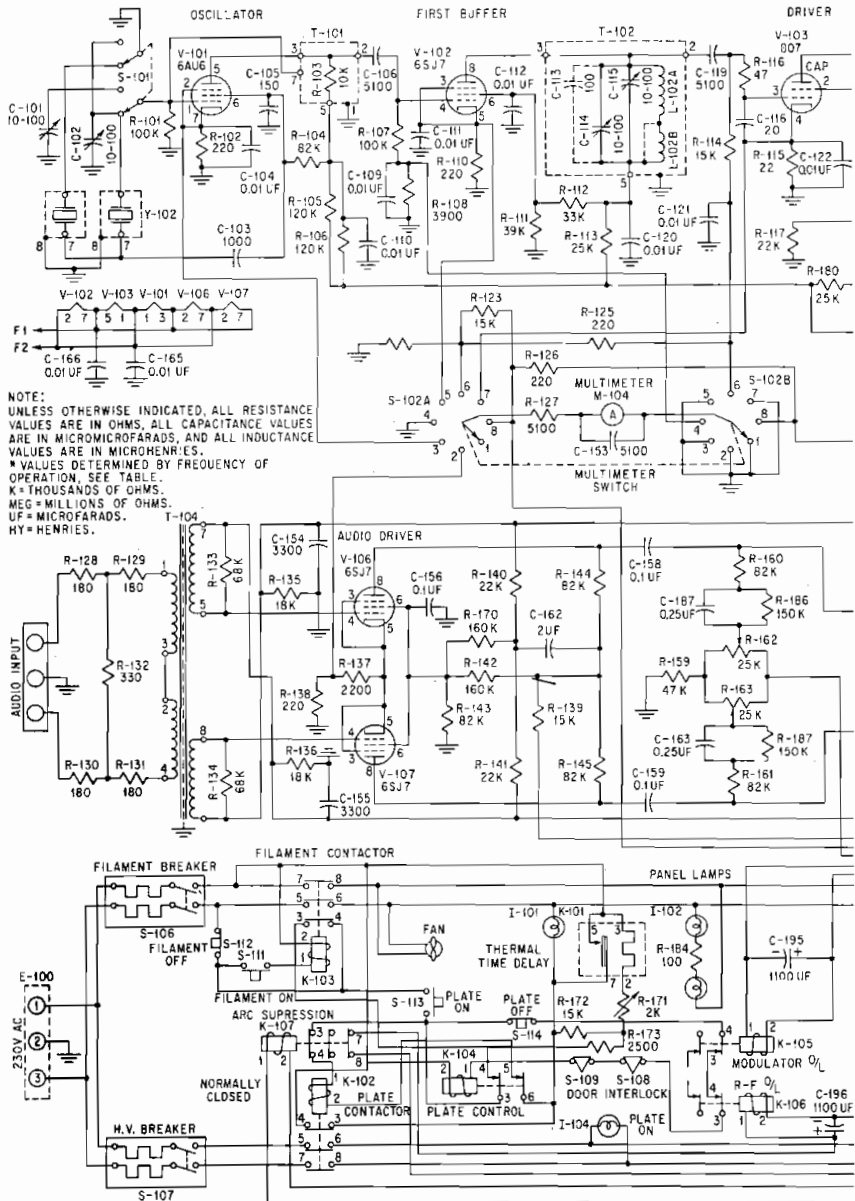
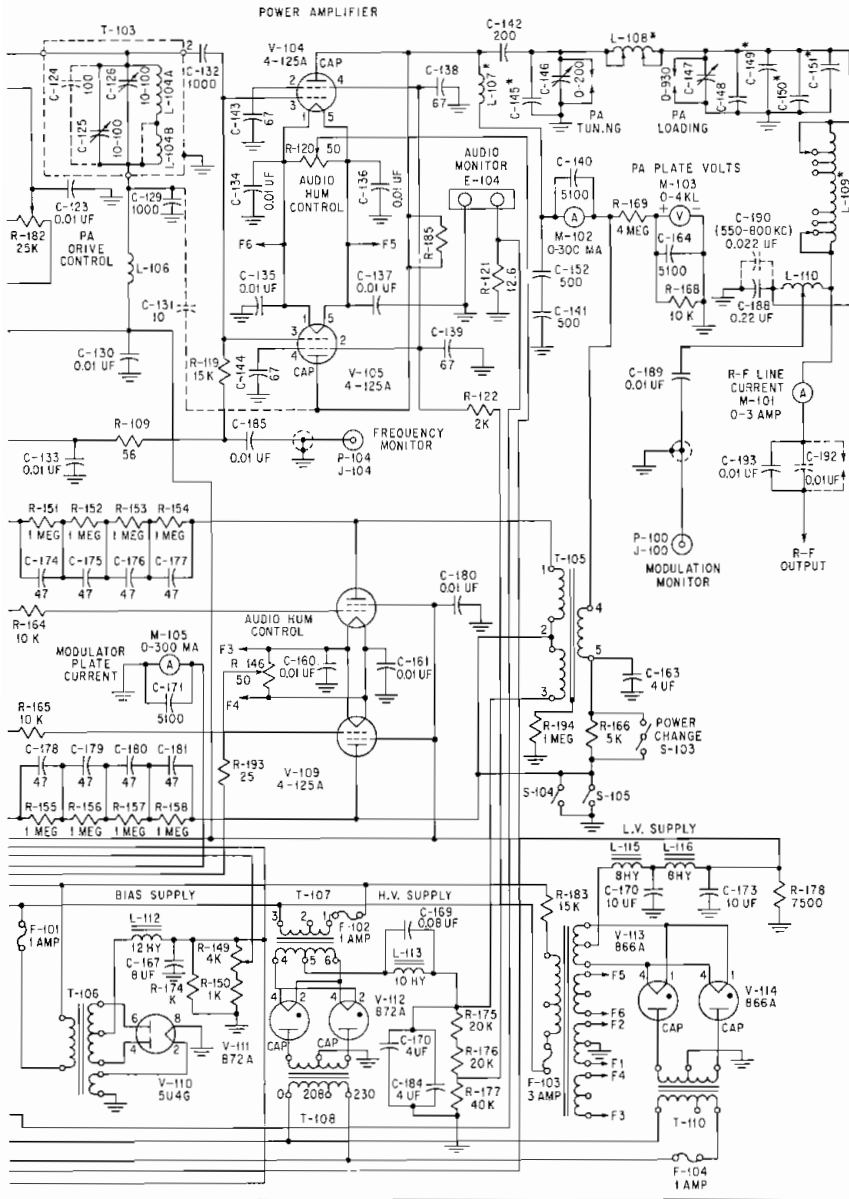

FIG. 1-21. Schematic diagram Collins 300J-2 transmitter (250-watt). (Courtesy of Col-



(ins Radio Company.)

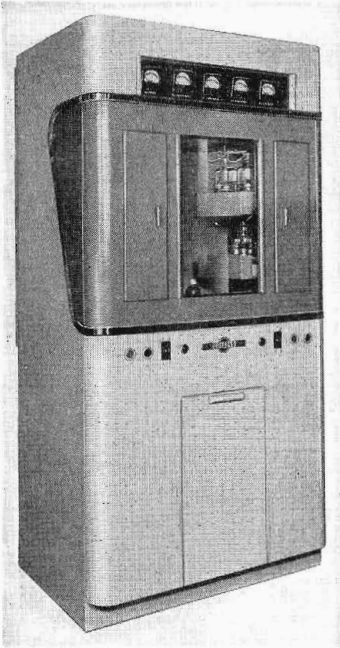

FIG. 1-22. Collins 300J-2 (250-watt) and 20V-2 (1,000-watt) AM broadcast transmitters. These transmitters have the same external appearance. (Courtesy of Collins Radio Company.)

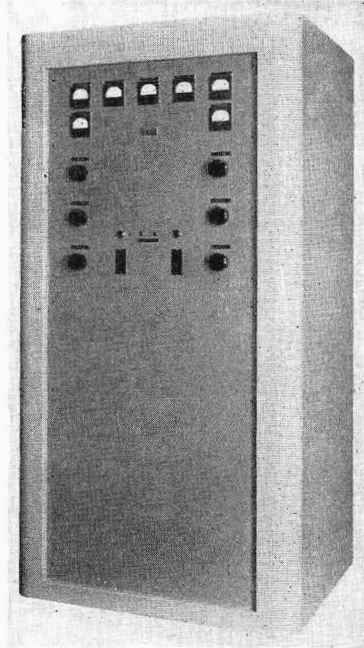

FIG. 1-23. Gates BC-250-GY (250-watt) AM broadcast transmitter. (Courtesy of Gates Radio Company.)

TRANSMITTER MAINTENANCE

A transmitter can give reasonably trouble-free performance year after year only if it receives regular maintenance. Manufacturers' instruction books usually contain maintenance information applicable to each specific transmitter, but the following general principles may be useful.

At most stations, a routine maintenance system is set up by the station engineer for guidance of maintenance personnel. Various maintenance operations are usually listed on cards or sheets, with spaces provided for the maintenance engineer to initial and date each operation as it is completed. Maintenance operations are classified on these cards or sheets according to the frequency with which they are repeated, such as weekly, monthly, or semiannually. Following are some of the most important maintenance operations.

Cleaning

All equipment, particularly tubes, insulators, and other high-voltage components, must be kept free of dust and oily deposits. A source of medium-pressure air is useful for removing dust from hard-to-reach places, such as around terminal boards or between capacitor plates.

Some stations install small air-compressor units for this purpose, but in most cases, vacuum cleaners with suitable attachments are used.

It has been argued that blowing the dust from these inaccessible places is ineffective, since much of it will settle back again. If a vacuum system with adequate suction

were available, it would doubtless be better for removing the dust. Unfortunately, an ordinary vacuum cleaner does not develop enough suction for this purpose. One technique that has been used successfully is first to blow dust from hard-to-reach places. After the dust settles, use a dust cloth on all accessible surfaces. Finally, use a suction device to remove the loose dust from inaccessible places.

A cloth moistened with carbon tetrachloride is effective for removing oily deposits. The use of lintless cloths is recommended for transmitter cleaning and for removing the film residue left by carbon tetrachloride.²

The frequency with which the cleaning operation needs to be repeated depends upon transmitter construction and local conditions. Many stations put this maintenance activity on a monthly schedule.

Air Filters

Nearly all modern standard broadcast transmitters are air cooled; thus proper care of the air filters is most important. They should be inspected at least once each month.

When dirty, the filters must be replaced or cleaned and recharged, depending upon the type used. Specific information on the care of air filters can usually be found in the individual transmitter instruction book.

Tightening

All connections involving screw-type terminals should be periodically checked for tightness. This can be done on a semiannual or annual basis in most cases.

Breakers, Switches, Contactors, and Relays

At least once yearly or in case of repeated tripping, the contacts of main circuit breakers should be inspected. If badly pitted, they should be repaired as recommended by the manufacturer. In breakers using dashpot timers, the liquid level should be checked semiannually and filled to the indicated level.

The operation and timing of all time-delay relays should be checked periodically. Small relay contacts can be cleaned, if needed, with Kraft paper. Badly pitted contacts should be smoothed with a fine file or burnishing tool.

Contactors should be checked for burned or pitted contacts. A flat file and/or sandpaper should be used for correcting such conditions. Discretion should be used here, as it is possible to overmaintain these contacts.

It is essential that metal filings be kept out of all relays. Air should be used to blow out any filings which may have accumulated on the pole faces.

Contacts of overload relays should be inspected monthly and cleaned if necessary. Action of the relays should also be checked. After work of this kind, always allow time to test the transmitter before program time.

Door interlocks should be checked frequently for proper alignment and condition of contacts. Safety grounding switches, if used, should be checked in the same manner.

Rotating Equipment

Bearings of motors and blowers should be checked regularly for proper lubrication. It is well to follow the manufacturer's recommendations very closely in this case, since it is possible to overlubricate as well as underlubricate many bearings.

Drive belts should be inspected frequently for signs of wear and for proper tension. Impeller blades on blowers should be kept free of dirt and oil. If rust spots develop, they should be scraped clean and repainted.

² Observe safety precautions when using carbon tetrachloride.

High-power Tubes

New tubes should be inspected, when received, for possible damage resulting from shipment. Each new tube should be used in the transmitter for at least one day as soon as possible after it is received. Spare tubes should be given one day of regular operation every six months. This will clean up any gas that may have been liberated and assures that spares are in usable condition.

Records should be kept on the life of high-power tubes. This is usually done by assigning a card to each tube. The tube hour-meter reading is then recorded on the card each time the tube is installed and removed from the transmitter.

When a new tube is first placed in service, it should be operated at rated filament voltage without plate voltage for 15 min. Approximately half of the normal plate voltage should then be applied for 15 min, followed by full plate voltage for 15 min. Modulation should then be applied gradually up to 100 per cent. If a gas kick occurs at any point in the process, plate voltage should be reduced to the previous level and additional aging time allowed.

Rectifier Tubes

When first placed in service, high-power mercury-vapor rectifier tubes should be operated for at least 30 min with normal filament voltage but without plate voltage.

Spare rectifier tubes should be given a one-day period of operation in the transmitter every six months.

In addition to keeping life records for these tubes, it is desirable to make a monthly check of the peak breakdown voltage of each tube in service. One method of making this check is as follows:

1. Remove the regular plate connection from the tube and apply filament power.
2. Connect the 120-volt secondary winding of a 300-volt isolation transformer in series with the tube and a 50-ohm 200-watt current-limiting resistor.
3. Connect the vertical deflection plates of an oscilloscope across the tube.

The pattern of tube voltage will show a sharp peak at start of conduction, and the amplitude of the voltage at this point indicates the initial breakdown voltage of the tube. Peak breakdown voltage of a good tube will be between 10 and 20 volts. When this value reaches 30 volts, arc backs may be expected. When it reaches 50 volts, the tube probably should be replaced.

Small Tubes

Small tubes should be tested when received, either in the transmitter or with a portable tube tester. This process should be repeated at six-month intervals.

PERFORMANCE TESTS

A regular schedule of performance tests should be included in the maintenance routine. This is done each month at many stations but less frequently at others. The following measurements should be included:

1. Carrier noise level
2. Distortion at 95 per cent modulation from 50 to 7,500 cycles
3. Audio response from 30 to 10,000 cycles
4. Carrier shift at 400 cps with 100 per cent modulation

Another item, which might be called a performance test, is to obtain a measurement of the carrier frequency of the station from an outside source.³ This probably need not be done more often than semiannually with modern transmitters. However, many broadcasters make such checks on a monthly basis.³

³ Not required by the FCC.

PERSONNEL TRAINING

Despite the most careful maintenance, every transmitter will occasionally fail during regular program transmission. Since time off the air means lost revenue to stations, it is imperative for transmitter personnel to locate and remedy the source of trouble quickly. Each individual should study the equipment, the circuit diagrams, and the instruction books until he is familiar with every part of the transmitter.

A further step in personnel training is a program of simulated failures. This must be carried on during off-the-air time. It consists of one member of the staff (usually the station engineer) deliberately placing a fault in the equipment, after which other staff members observe the fault symptoms and endeavor to locate and correct the trouble as quickly as possible.

Such a program is difficult to carry out in a standard broadcast station where off-the-air time usually occurs after midnight. However, it has proved to be very effective in improving personnel efficiency.

Part 2

FM TRANSMITTERS *

H. S. WALKER

*Broadcast Transmitter Engineering
Technical Products Department
General Electric Company
Electronics Park
Syracuse, New York*

INTRODUCTION

Since the introduction of frequency modulation by Major E. H. Armstrong in 1936, a large variety of circuits have been developed to produce FM. Only those circuits used for FM broadcast will be discussed.

The original Armstrong modulator used a balanced modulator generating sidebands with a suppressed carrier in one path and a 90° phase-shift circuit in the other path. The two signals were then added to each other to produce phase modulation (PM), with modulation capabilities of $\pm 30^\circ$ and good linearity. A large number of multipliers were required to achieve a total deviation of 75 kc at the lower audio frequencies. In general, the PM signal was multiplied a number of times, then heterodyned down to a lower frequency, and again multiplied to obtain the desired final operating frequency. The use of a correction network in the audio input line converts the PM characteristic to that of FM.

MODULATION THEORY

There are basically two modulation methods that have been used in postwar FM transmitters. The first is direct FM, using a stable oscillator with a reactance-control tube or device across the frequency-determining circuit and a servo circuit to stabilize the mean center frequency by comparing it with a reference crystal oscillator. The second is indirect FM, using phase modulation of a crystal-controlled crystal carrier with a large number of multipliers to achieve the desired frequency deviation.

A variety of circuits were developed by a number of manufacturers to control the mean center frequency accurately. The direct FM method requires the use of a frequency-comparison circuit. In some cases, the output from these circuits is a two-phase voltage used to control the mean center frequency through a motor-driven

* The author wishes to thank Mr. D. A. McCormick of Standard Electronics Corporation, Messers A. H. Bott and J. A. Aurand of the Radio Corporation of America, Mr. Bernard Wise of the Industrial Transmitters and Antenna Company, and the Gates Radio Company for supplying the material pertaining to their equipment.

capacitor connected across the oscillator frequency-controlling circuit. In other cases, the output is in the form of a d-c voltage applied directly to the frequency-controlling element of the modulation reactance tube. The amplitude and polarity of the d-c voltage depend on the direction and magnitude of frequency shift of the modulated oscillator.

An unmodulated carrier wave is a single-frequency, constant-amplitude, sinusoidal wave. To transmit intelligence, this wave must be varied in some way. This process of superimposing intelligence on a carrier wave by some variation is known as modulation.

There are two fundamental forms of modulation:

1. Variation of amplitude (AM)
2. Variation of repetition rate (FM or phase modulation)

More complicated systems of modulation are actually variations or combinations of these fundamental methods.

Considering a very simple case of a carrier that is amplitude modulated with a single-frequency sine wave, we can express the result mathematically in the following manner:

$$e = E(1 + m \cos \Omega t) \cos \omega t \tag{2-1}$$

where m is the modulation factor.

$$\begin{aligned} e &= E(\cos \omega t + m \cos \Omega t \cos \omega t) \\ &= E[\cos \omega t + \frac{m}{2} \cos (\omega + \Omega)t + \frac{m}{2} \cos (\omega - \Omega)t] \end{aligned} \tag{2-2}$$

Equation (2-1) is in the form of a sine wave of carrier frequency with an amplitude that varies at the modulation rate. This might be shown in pictorial form similar to that in Fig. 2-1.

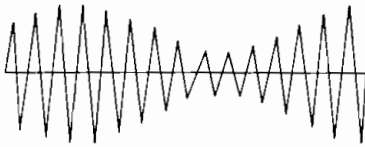

FIG. 2-1. Amplitude-modulation RF envelope.

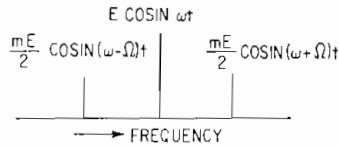

FIG. 2-2. AM sideband representation.

On the other hand, Eq. (2-2), which was derived directly from Eq. (2-1), shows that there are three frequencies present: the carrier frequency, having the same angular velocity ω as the original unmodulated carrier and the same amplitude E , and also two angular velocities $\omega + \Omega$ and $\omega - \Omega$ which correspond to frequencies above and below the carrier frequency, separated by the modulating frequency, as shown in Fig. 2-2. This can also be represented in vector form as shown in Fig. 2-3.

These three ways of representing or picturing an amplitude-modulated wave are not different things but are merely somewhat imperfect ways of trying to visualize a single phenomenon, as is evident when we realize that they come from the same mathematical formula merely changed in form by straightforward trigonometry from Eq. (2-1) to Eq. (2-2).

Phase modulation can be expressed mathematically by the expression

$$e = E \sin (\omega t + \phi) \tag{2-3}$$

where ϕ varies with modulation, so that

$$e = E \sin (\omega t - m \sin \Omega t) \tag{2-4}$$

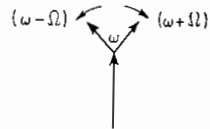

FIG. 2-3. Simplified AM vector representation.

This is in a form similar to that of Eq. (2-1) for amplitude modulation.

In phase modulation, m is a modulation factor similar to the modulation factor used in AM and represents the maximum angular deviation during modulation.

In frequency modulation, where a fixed value of modulation represents a certain frequency deviation, we make the modulation factor

$$m = \frac{\Delta\omega}{\Omega} \quad (2-5)$$

where $\Delta\omega$ is the maximum departure of the angular velocity from the unmodulated value during modulation and Ω is the modulating frequency.

Now, expanding this expression,

$$e = E[\sin \omega t \cos (m \sin \Omega t) + \cos \omega t \sin (m \sin \Omega t)]$$

However,

$$\cos (m \sin \Omega t) = J_0(m) + 2[J_2(m) \cos 2\Omega t + J_4(m) \cos 4\omega t + \dots]$$

and

$$\sin (m \sin \Omega t) = 2[J_1(m) \sin \Omega t + J_3(m) \sin 3\Omega t + \dots]$$

Therefore,

$$e = E \sin \omega t \{J_0(m) + 2[J_1(m) \sin \Omega t + J_2(m) \cos 2\Omega t + \dots]\}$$

$$e = E \{J_0(m) \sin \omega t + J_1(m)[- \cos (\omega + \Omega)t + \cos (\omega - \Omega)t] + J_2(m)$$

$$[\sin (\omega + 2\Omega)t' \sin (\omega - 2\Omega)t] + \dots \} \quad (2-6)$$

This is similar in form to Eq. (2-2) for AM in that it consists of a carrier-frequency term and side frequencies. In this case, however, the carrier amplitude varies with modulation, and there is a series of side frequencies spaced from the carrier by multiples of the modulating frequency.

We can represent a frequency-modulated wave pictorially as shown in Fig. 2-4.

A vector representation is valid only for very small angular deviations, but for this special case it is that shown in Fig. 2-5.



FIG. 2-4. Frequency-modulation RF envelope.

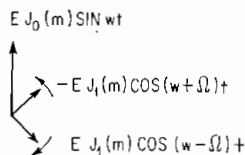

FIG. 2-5. Simplified FM vector representation for small deviation ratios.

The absolute magnitude of sideband-spectrum representation corresponding to Fig. 2-2 for AM is shown in Fig. 2-6 for three different deviation ratios.

The Bessel functions $J_0(m)$, $J_1(m)$, etc., which expressed the magnitudes of the various frequency components, can be obtained from mathematical tables in exactly the same way as we find values of the ordinary circular functions \sin , \cos , etc.

We can make practical use of many of the properties of these Bessel functions. For instance, we notice that $J_0(x)$ goes to zero for certain values of x : $x = 2.4048$, 5.5201 , 8.6537 , The J_0 function describes the amplitude of the carrier for any modulating frequency and deviation.

The following is an example of the application of this method. Using a selective AM receiver tuned to the IF of the station modulation monitor or a good FM receiver, modulate the FM transmitter with an audio tone of 8,666 cycles. It will be observed

FM Transmitters

that as the level of the audio signal is increased, the carrier will disappear for c levels of audio signal. If the audio level is gradually increased until the carrier gone to zero three times, then the transmitter will have a deviation of ± 75 kc.

$$8.666 \times 8.6537 = 75 \text{ kc}$$

Using this method, any value of deviation can be accurately determined by choosing the proper Bessel function and audio-modulating frequency.

BANDWIDTH

A study of the Bessel functions also shows us the requirements for bandwidth with frequency modulation. Theoretically, the bandwidth is infinite, but practically we

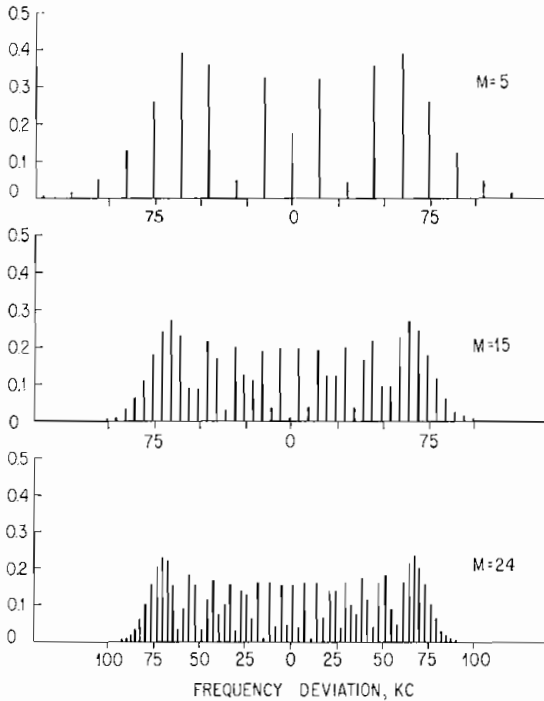

FIG. 2-6. Sideband amplitudes of a frequency-modulated wave.

see from Fig. 2-6 that the amplitudes of the side frequencies beyond the maximum swing become very small and can be neglected. We should remember, however, that even for very small swings, we need a bandwidth sufficient to include the first-order sidebands or no intelligence will be included.

A good "rule of thumb" for bandwidth (BW) requirements is

$$BW = 2(f_m + \Delta f)$$

where f_m is the modulating frequency and Δf is the maximum frequency deviation. Though this rule is not accurate, it is a good practical method for ordinary use.

Insufficient bandwidth results in distortion of the modulation. This is different from the case of AM, in which restricted bandwidth affects the frequency response

of the system but does not affect wave shape. It should also be noted that to have frequency modulation free of distortion, the system should have all frequency components transmitted not only without relative changes in amplitude but also without relative phase changes. This means that there must be a flat frequency response within the passband and a linear phase characteristic.

A frequency-modulation system, however, does not require a linear amplitude response, and in fact, its chief advantage, that of noise reduction, is obtained by purposely introducing an extremely nonlinear element, the limiter, in the receiver.

NOISE REDUCTION

The effect of a limiter in reducing noise is most easily visualized by the method used by Roder in his article, *Noise in Frequency Modulation*, *Electronics*, May, 1937. This explanation uses a vector representation of the frequency-modulated wave similar to that of Fig. 2-5, except that when we are considering large frequency swings, we cannot show the various frequency components and the wave is represented merely as a single vector which must be pictured as rotating back and forth through the angular deviation caused by the modulation. The noise is represented as a vector having a magnitude equal to the peak value of the noise and any arbitrary phase.

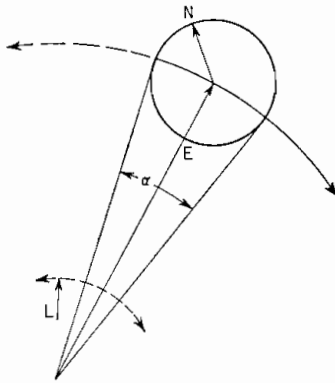

E - CARRIER
N - NOISE
L - LIMITED CARRIER PLUS NOISE
 α - MAXIMUM VALUE OF 90°

FIG. 2-7. Simplified vector diagram of noise added to the RF carrier.

It can be seen from the diagram in Fig. 2-7 that, if the peak noise amplitude is less than the signal, it can produce a phase modulation not greater than $\pm 90^\circ$. If the amplitude variations are removed by limiting, the noise contribution will be reduced by a factor which varies with the ratio of this angle to the maximum deviation angle of the frequency-modulated signal.

Mathematically, the reduction of noise can be expressed as a wideband gain

$$G = \sqrt{3} \cdot \frac{\Delta f}{f_m}$$

where f_m , in this case, is the highest modulating frequency to be transmitted by the system and Δf is the maximum frequency deviation.

It should be noted that this gain holds only for signal levels where the signal is greater than the noise and that below this value, which is called the threshold, the signal is rapidly wiped out by the noise.

PREEMPHASIS

Further improvements in the signal-to-noise ratio of a system transmitting voice or music can be obtained by the use of preemphasis and deemphasis. This system takes advantage of the fact that very little energy is normally contained in the higher frequency components of speech or music by distorting the frequency response of the transmitter input so that above a frequency of, let us say, 1,500 cycles the amplitude increases in proportion to the frequency. A compensating network in the receiver restores the over-all frequency response of the system.

The gain resulting from the use of preemphasis with FM takes advantage of the fact that the noise of a flat system is proportional to the modulating frequency. This effect is shown graphically in Fig. 2-8.

The improvement is not quite so great as the ratio of areas, since the audio input level must be reduced slightly to prevent overmodulation by high-frequency components, but for an audio spectrum up to 15,000 cycles, a preemphasis of 75 μsec gives a gain of about 10 db.

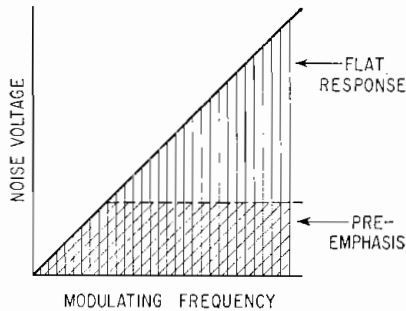

FIG. 2-8. Gain resulting from the use of preemphasis with FM.

This same gain for preemphasis cannot be obtained with AM because it does not have a triangular noise spectrum.

COMMERCIAL FM BROADCAST EQUIPMENT

Direct FM System

The first postwar FM transmitter manufactured by RCA (the type BTF-250A) used push-pull reactance tubes connected across the frequency-determining circuit of the modulated oscillator. The automatic frequency-control circuit is completely independent of the modulator circuit. Center-frequency stability is maintained by comparing a subharmonic of the modulated signal against a standard temperature-controlled oscillator. The error signal resulting from any difference between the mean frequency of the modulated oscillator and the standard oscillator is used to drive a two-phase motor that positions a condenser connected across the frequency-determining circuit of the modulated oscillator. The advantages of this type of modulator are that small frequency multiplication is required and very low harmonic distortion is introduced by the reactance modulator tubes.

Phasitron System

The Phasitron¹ modulator was originally proposed by Dr. Robert Adler of the Zenith Radio Corporation. It requires the use of a special tube developed for this type of service by the General Electric Company. This development permitted a reduction in the number of multipliers required.

A crystal-controlled carrier is first generated by the crystal oscillator. A phase-splitting network supplies the three-phase voltage for the deflector elements. An audio air-cored inductor is placed around the tube so that the axes of the coil and tube are the same. The coil is designed to appear as nearly as possible like a pure inductance over the entire audio-frequency range. When a constant voltage is held across the coil at all audio frequencies, the current through the coil and, consequently, the magnetic field in the Phasitron tube will be inversely proportional to the modulation frequency. This is exactly the condition required to convert from phase modulation to frequency modulation. The Phasitron is capable of ± 3.5 radians as compared

¹ Registered U.S. Patent Office.

Transmitters

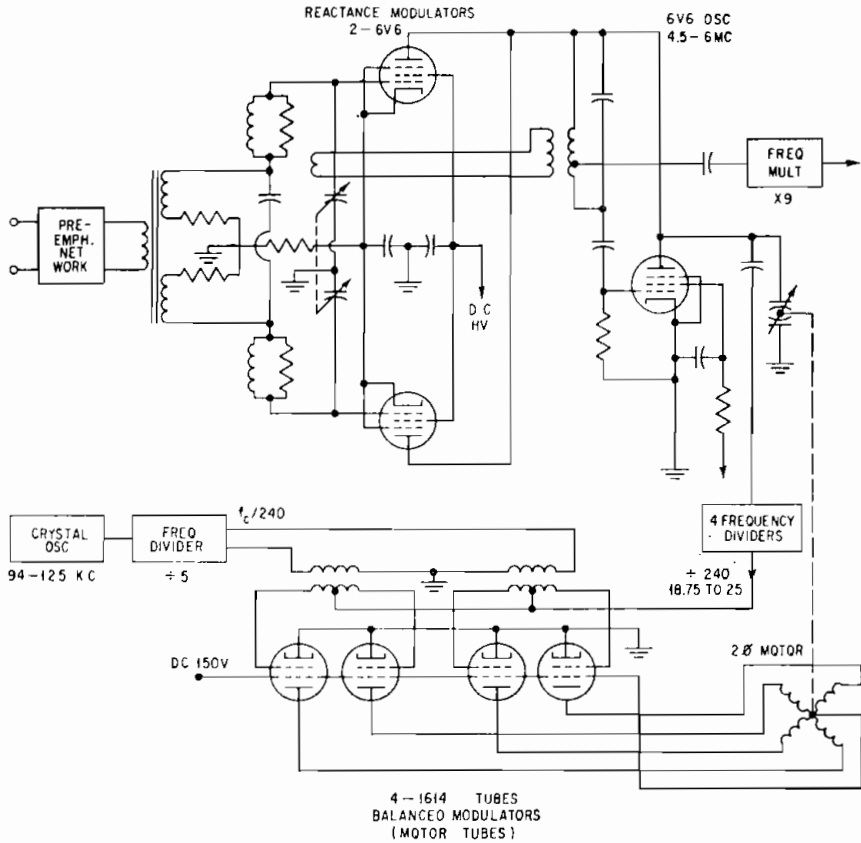

Fig. 2-9. Frequency-controlled FM modulator.

with approximately ± 0.5 radians, using a conventional phase modulator with corrections circuits. Using ± 3.5 radians as the maximum phase shift obtainable, the required multiplication rate can then be calculated as follows:

$$M = \frac{f}{f_a \phi} = \frac{75,000}{50 \times 3.5} = 428$$

Operating frequency = 88 to 108 Mc

M = multiplication rate

f = desired frequency deviation, ± 75 kc

f_a = lowest audio frequency to be used, 50 cycles

ϕ = phase shift, radians

The lowest multiplication number that can be obtained using only doublers and triplers is 432 times. This is the multiplication rate used by most manufacturers employing the Phasitron for standard FM broadcast use. When RF feedback is used, the distortion at the lower audio frequencies can be made to be less than 1 per cent.

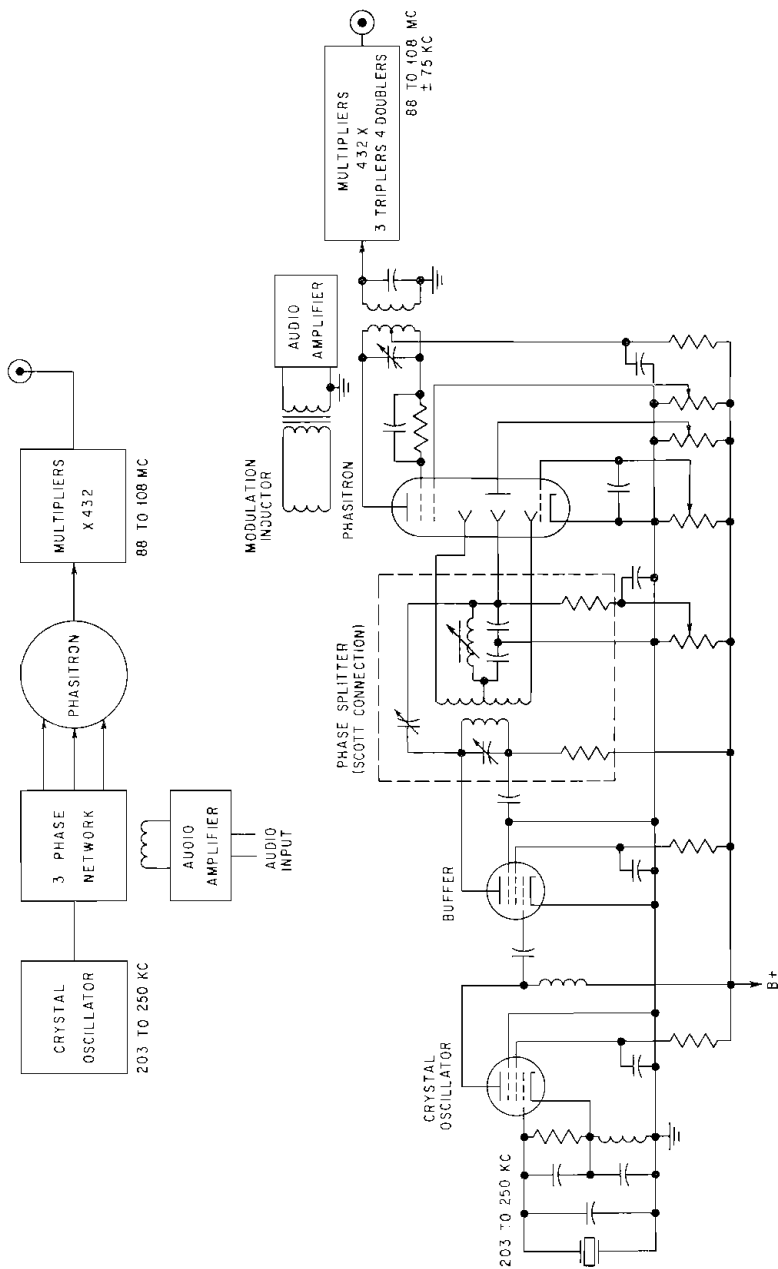

Fig. 2-10. General Electric Phasitron FM modulator.

INDUSTRIAL TRANSMITTERS AND ANTENNA COMPANY

A brief description of the ITA Company FM transmitters follow. The discussion is divided into the following categories: (1) General Packaging, (2) Meter and Control Circuitry, (3) Exciter, (4) RF Power Amplifiers.

General Packaging

The modern FM transmitter should be compact and capable of being placed in a facility having restricted floor space. It should be capable of being operated by remote control and should require only periodic maintenance. In addition, it must

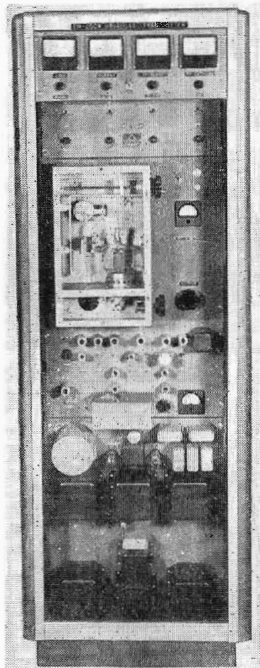

FIG. 2-11. ITA 250-watt FM transmitter.

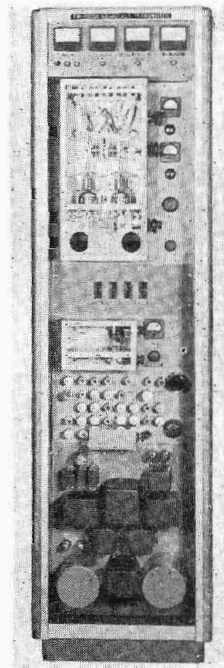

FIG. 2-12. ITA 100-watt FM transmitter.

conform to the latest FCC specifications, which endeavor to limit spurious emissions and cabinet radiations.

Bearing these requirements in mind, the ITA transmitter designs utilize only high-gain stages wherever possible. This reduces the total number of components, thereby reducing the over-all size of the package. For example, the 5-kw transmitter requires only 9 sq ft of floor space. In addition, all the components are mounted in vertical panels. This permits ease of viewing circuits and trouble-shooting when necessary. Every wire that enters an RF enclosure in the transmitter passes through a feed-through capacitor, thus reducing the possibility of cabinet radiation. Every effort has been made to utilize commercially available components. The selection of standard components assures the broadcaster of proved reliability and ready availability of replacement parts. Figure 2-11 and 2-12 exemplify the packaging of the transmitter.

Meter and Control Circuitry

The function of the meters and the controls in the transmitter is quite apparent. However, as mentioned above, in the majority of cases the FM transmitter will be operated unattended and will be controlled from some remote location. Thus, all the meter circuits, except for AC line voltmeter, are connected to ground. In order to read their indications remotely, a sampling resistor is inserted between the meter and ground and the voltage developed across it is applied to a remote meter line. For the same reason, each transmitter has control circuits which require only the application of line voltage before the transmitter will automatically advance through the various stages of filament, exciter, and amplifier plate and screen voltages. Provisions have been made available to control the various supplies in the equipment independently. Time-delay units are used throughout to prevent the application of voltage prior to adequate preheating of rectifier and power tubes.

Exciter

The method used for achieving frequency modulation in the ITA exciter is by the "indirect," or phase-modulation, method. In this system, the oscillator circuit is not affected by the modulation, and thus, carrier-frequency stability is dependent only on the oscillator circuitry components.

The major limitation of a phase-modulating system is that the maximum frequency deviation that can be obtained is a very small percentage of the modulating frequency. Thus, in order to obtain the required 75-kc deviation at low audio frequencies, modulation must occur at a very low subharmonic of the carrier. This frequency is then multiplied manyfold. Multiplication also increases the deviation.

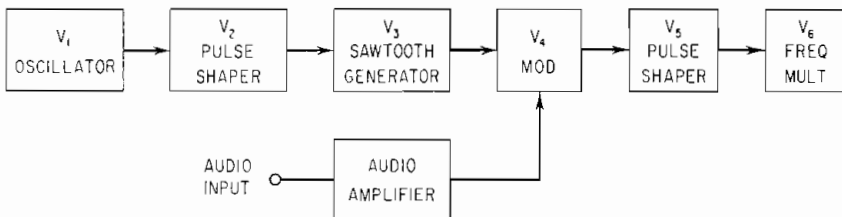

FIG. 2-13. Block diagram of basic Serrasoid FM modulator.

A type of phase modulation, developed by J. R. Day and commonly referred to as a Serrasoid modulator,² has greatly extended the modulation capability of phase modulators using conventional tubes. Figure 2-13 is a block diagram of the basic exciter which uses this system. V_1 is a conventional crystal-controlled oscillator. V_2 modifies the oscillator waveform into pulses. These pulses trigger V_3 , a sawtooth oscillator. The output of the sawtooth oscillator is fed to the grid of the modulator tube V_4 . Owing to the grid conduction of this stage, the sawtooth is truncated. Figure 2-14a represents the waveform at the grid of V_4 . Thus, if the grid voltage is varied at an audio rate, the point of truncation can be changed. Figure 2-14b shows the waveform at the input to V_4 under the condition of audio modulation; V_5 differentiates the output of V_4 so that it produces a pulse at the point at which truncation occurs. Because of the modulation process, the point of truncation and, thus, the output pulse from V_5 will change in time position. Figure 2-14c describes this action.

V_6 is a frequency multiplier. The pulses from the preceding stage drive V_6 into saturation, and its output tank circuit is tuned to a harmonic of the oscillator frequency. As these pulses change in time position owing to modulation, the output sine wave of V_6 changes in phase. The carrier has become frequency-modulated at the audio rate.

² Registered U.S. Patent Office.

Following V_6 are a number of Class C frequency multipliers which produce the output carrier frequency. Interconnecting each of these stages are double-tuned circuits.

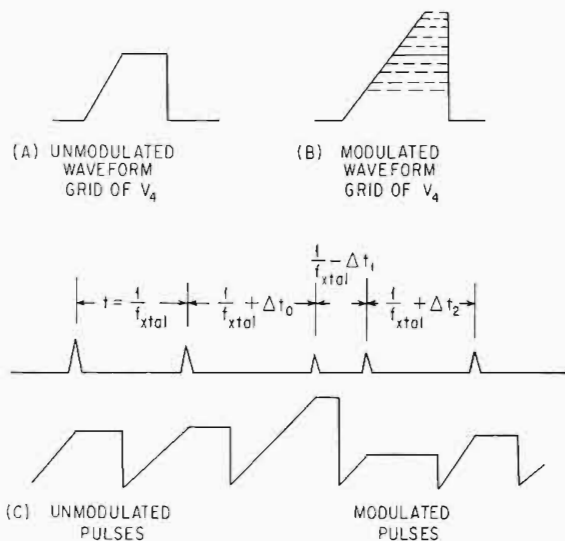

FIG. 2-14. Typical RF waveforms of the Serrasoid modulator.

Figure 2-15 is a picture of the ITA exciter. It utilizes 14 tubes and has a multiplication factor of 864. All the stages can be tuned from the front panel by maximizing the grid drive to the RF multipliers. These transformers are pretuned at the factory and rarely require any field adjustment. The output power of the exciter is 10 watts at the final frequency.

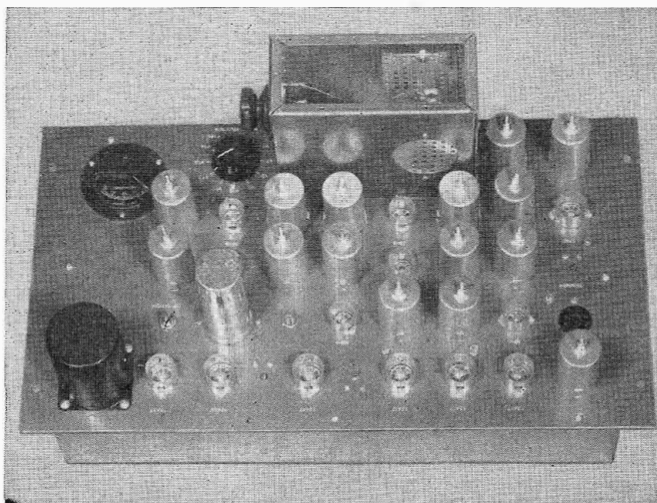

FIG. 2-15. ITA FM exciter.

RF Power Amplifiers

There are available today a number of power tubes with extremely large transconductances which, when driven by a modest power, can produce substantial power outputs. Their proper selection will result in transmitter simplicity, economic packaging, minimum operating expense, and trouble-free operation.

The following tubes are used at the various power levels for commercial FM broadcast transmitters manufactured by ITA:

Drive Requirement, Watts	Power Output, Watts	Tube Types
5	250	4-250A
10	500	4-400A
20	1,000	(2) 4-400A
200	5,000	4CX5000A

For ease of explanation, the discussion that follows will be divided into three sections: input circuit, neutralization, and output circuits.

Input Circuit of Class C RF Power Amplifier

The grid circuit of an RF amplifier at 100 Mc is determined by the magnitude of the grid-to-cathode interelectrode capacitance and the inductance within the tube

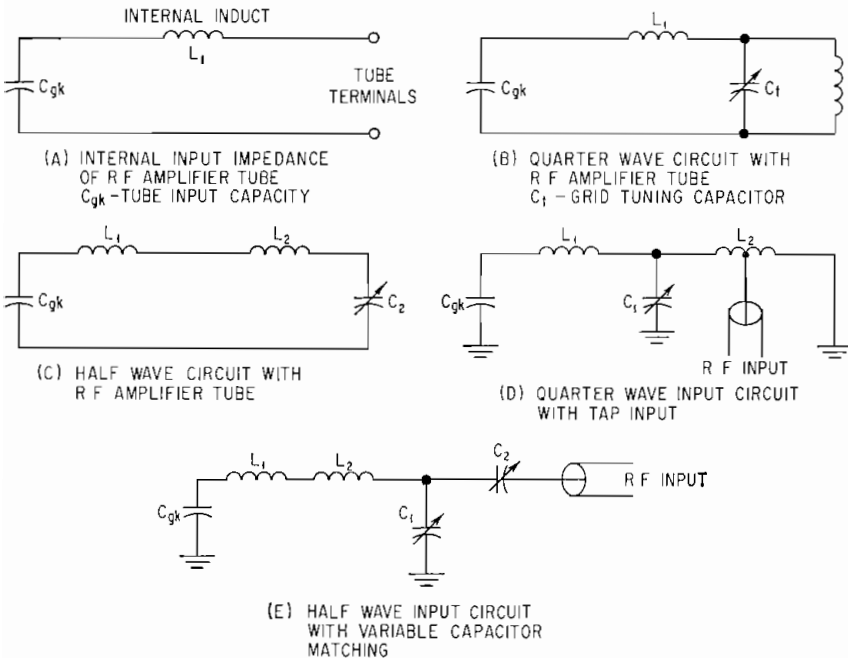

FIG. 2-16. Equivalent circuits.

envelope between the electrodes and its terminals. Fig. 2-16a represents an equivalent circuit for this capacitance and inductance. If this combination is resonant at a frequency higher than the desired frequency, resonance can be obtained by adding a fixed inductance external to the tube. Tuning can be accomplished by using

variable air capacitors or changing the amount of external inductance. Figure 2-16*b* describes this "quarter-wave mode" of operation.

If the combination of the input electrode capacity and lead inductance is resonant at a frequency lower than the desired operating frequency, the combination pictured in Figure 2-16*c*, commonly referred to as a half-wave mode, can be used. Since the latter arrangement is a longer circuit electrically, it represents a greater storage of energy and, thus, will have less bandwidth than the quarter-wave circuit described earlier. Nevertheless, both circuits will normally provide adequate bandwidth for FM transmission.

The question now arises as to how to couple into this type of circuit. One of the acceptable methods is to use a fixed tap a short distance away from the short-circuited end of a quarter-wave input circuit. This point should correspond to approximately 50 ohms in impedance when the input circuit is tuned to resonance. This coupling arrangement is shown in Fig. 2-16*d*.

When coupling into a half-wave circuit, the circuit shown in Fig. 2-16*e* can be used. Here the series coupling capacitor is approximately $5 \mu\text{f}$ when coupling a 50-ohm line into a stage utilizing one of the previously mentioned tetrodes. This is due to the fact that the series circuit of coupling capacitor and 50-ohm line represents a resistance of approximately X_c^2/R , which can be adjusted to match the high impedance present at the end of a half-wave circuit.

In the 1-kw transmitter, a push-pull arrangement is used. In order to drive this stage from an unbalanced line, a coupling loop is used. The use of a push-pull circuit reduces the input capacity to one-half the interelectrode capacity of a single tube. This reduction in capacity permits the use of a quarter-wave mode.

Neutralizing

To avoid introducing distortion and intermodulation, the amplifier must have a linear phase-vs.-frequency characteristic. This requires that the amplifier be well neutralized.

Most power tetrodes that are used in FM transmitter applications are so constructed

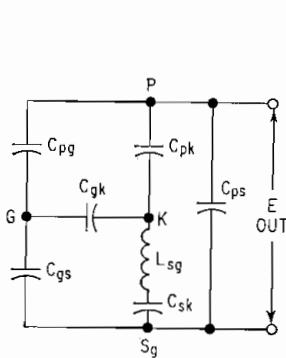

FIG. 2-17. Equivalent circuit of interelectrode capacities of a tetrode.

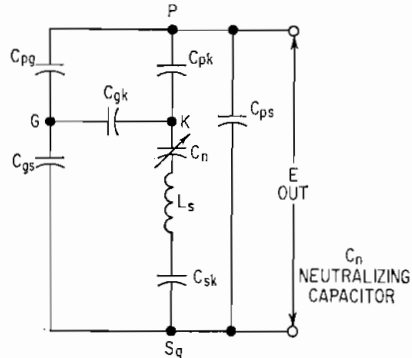

FIG. 2-18. Equivalent circuit of a tetrode with neutralizing capacitor in series with screen.

that their screen grids have considerable inductance between their active area and terminal connections. Figure 2-17 describes the equivalent circuit of a typical power tetrode, including the high interelectrode capacities and lead inductance. By referring to this figure, it can be seen that the output voltage of the stage is developed across a bridge circuit whose arms consist of the electrode capacitors and the screen inductance. If this bridge is balanced, the difference of potential across the grid-to-

cathode electrode capacity approaches zero. Accordingly, in this condition, the amplifier will be stable. Referring to Fig. 2-17, it is evident, however, that the screen inductance unbalances the bridge, so that the tetrode amplifier circuit will have feedback and oscillations can exist. In order to compensate for this unbalance, a series screen capacitor can be used to balance the bridge. Figure 2-18 describes the equivalent circuit of the arrangement.

In practice, the procedure used for neutralizing the stage with screen neutralizing is relatively simple. The input circuit is tuned for a maximum indication of grid current. An absorption meter is placed in the output circuit with the plate and screen voltages removed, and the plate circuit tuned for a maximum indication on the absorption meter. The screen neutralizing capacitor is then adjusted for a minimum indication on the absorption meter.

Output Circuits

The output circuits for the ITA, 250-watt and 1-kw transmitters are shown in Figs. 2-19 and 2-20.

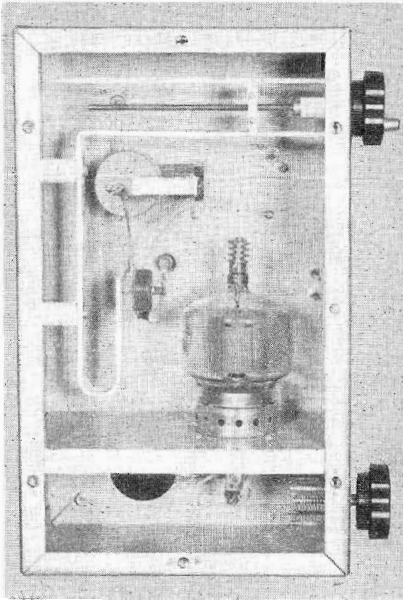

FIG. 2-19. ITA 250-watt RF amplifier.

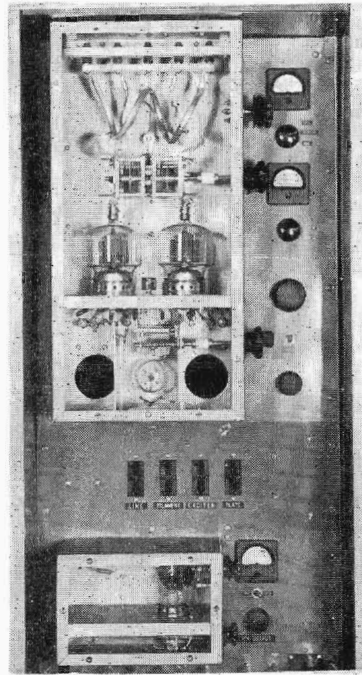

FIG. 2-20. ITA 1,000-watt RF amplifier.

The 250-watt amplifier has a capacity-tuned, quarter-wave plate tank circuit. The antenna is directly coupled to a low-impedance point through a d-c blocking condenser. Proper loading of the stage is achieved by varying the point at which the output line is tapped.

The 1-kw transmitter, using two 4-400A tubes operating in push-pull, also uses a quarter-wave, capacitively tuned plate tank. The antenna is inductively coupled to the final tank and is series-tuned for proper loading.

GATES RADIO COMPANY FM TRANSMITTER

The Gates FM-5B, 5,000-watt FM broadcast transmitter (Figs. 2-21 and 2-22) consists of a M5534 Serrasoid modulator exciter, a 4X250B intermediate-power amplifier, and a pair of 6076 tetrodes operating push-pull in a grounded-cathode circuit.

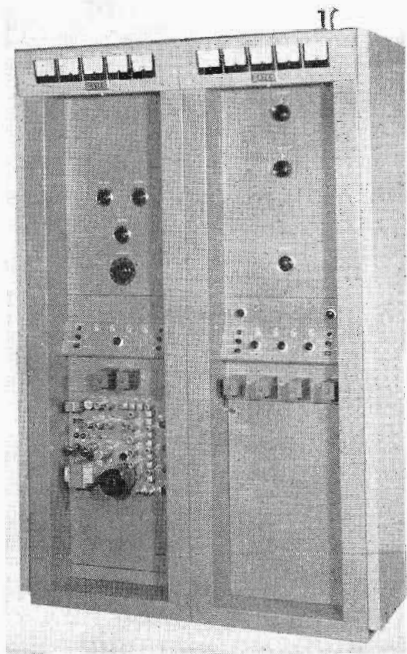

FIG. 2-21. Gates 5,000-watt FM-5B complete transmitter.

The exciter is constructed on a standard 19-in. panel for rack mounting. This unit is complete with its own power supply and has provisions between the fifth and sixth multiplier stages to insert additional multiplex channels from a separate chassis. The last stage in the exciter uses a type 6360 tube as an amplifier and can supply up to 10 watts for use as either a complete transmitter or as a driver for a higher powered amplifier. The operation of a Serrasoid modulator has been previously described.

The output from the exciter drives the intermediate-power amplifier. This amplifier consists of a single 4X250B tube operating in a grounded-cathode circuit.

The input is a half-wave circuit, with the output from the exciter inductively coupled to it. The driving power can be adjusted by varying the position of the loop. The plate circuit is a modified π , being capacity-tuned and capacity-loaded (see Fig. 2-23).

The final amplifier consists of two 6076 tetrodes operated in a push-pull grounded-cathode circuit. The input is again a half-wave capacitively tuned circuit. Input coupling is accomplished by connecting the inner conductor of the

transmission line from the driver to one grid line. The plate tank is electrically a quarter wave long and tuned by use of a vane. The output circuit is inductively coupled by means of an adjustable loop. For complete stability of the amplifier, cross neutralization is provided (see Fig. 2-24).

Each stage of the transmitter is metered by a multimeter system, and the power amplifier with a separate plate ammeter. Power output is monitored with a Micro-match directional coupler that is calibrated for power output and also standing-wave ratio. The amplifier tubes are air cooled by pressurizing a plenum chamber in which the grid circuit is also built. The transmitter is thoroughly protected from overloads and malfunctioning of other components, such as blowers and so forth.

STANDARD ELECTRONICS COMPANY FM TRANSMITTER

In the Standard Electronics FM broadcast 3-kw transmitter will be found the high degree of carrier stability inherent in a rigid control device. The generation of the RF signal from a quartz crystal oscillator with temperature control in an oven ensures a high degree of frequency stability. When this source of RF is used directly in a Serrasoid modulator, a combination of high-frequency stability, frequency response, and very low distortion can be achieved.

The frequency response and low distortion are produced by the circuitry of the Serrasoid modulator. The modulator is designed around four receiver-type tubes,

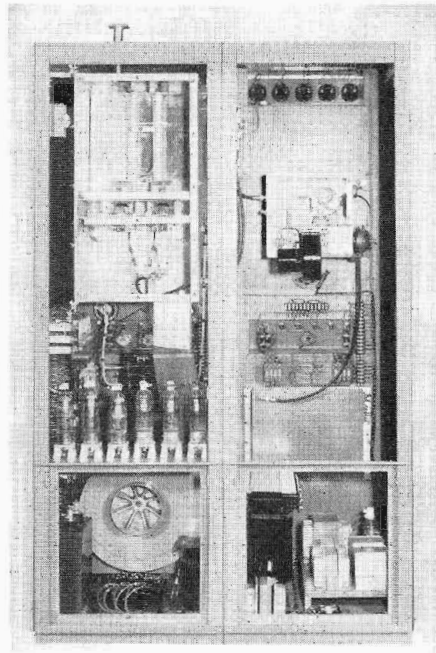

FIG. 2-22. Rear view of Gates 5,000-watt transmitter.

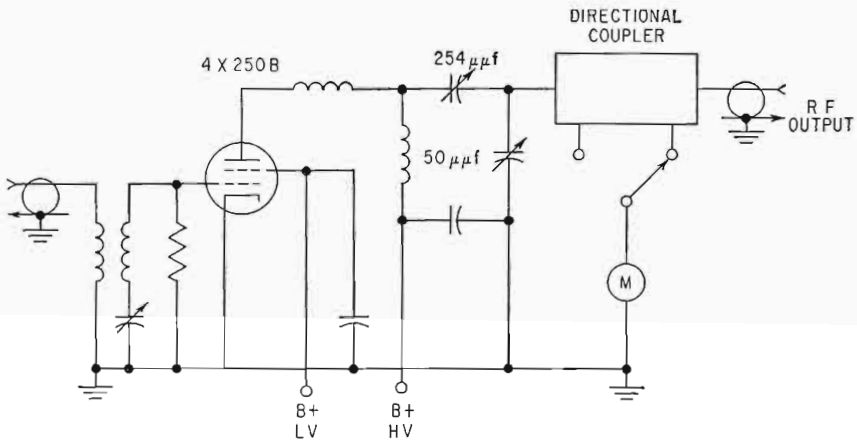

FIG. 2-23. Simplified schematic of Gates Radio Company FM-250B, 250-watt amplifier.

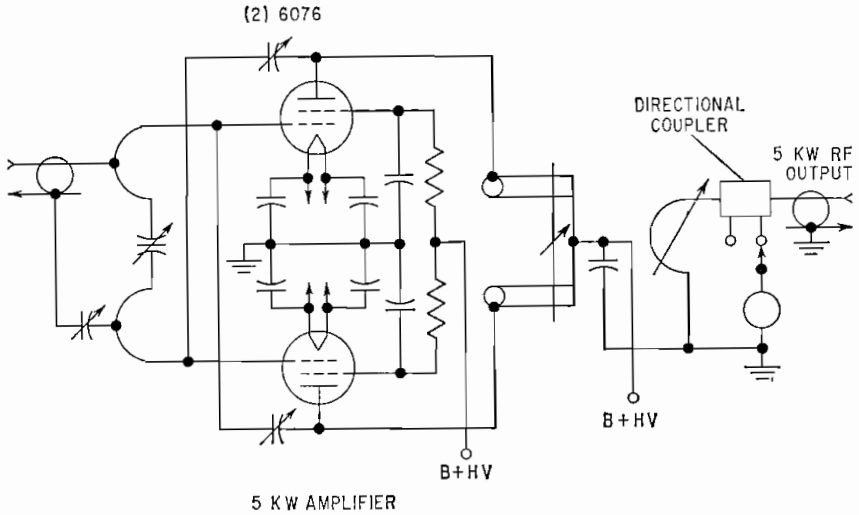

FIG. 2-24. Simplified schematic of Gates Radio Company FM-5B, 5,000-watt amplifier.

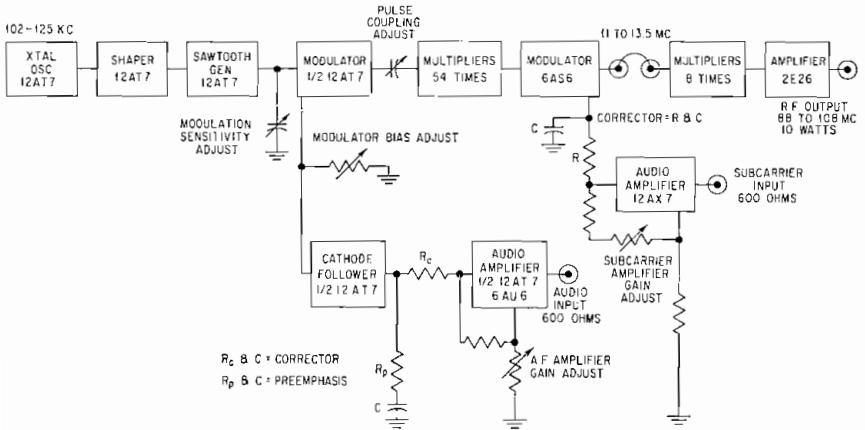

FIG. 2-25. Block diagram of Standard Electronics Serrasoid FM modulator.

V_1 and V_4 (12AT7's) (see Fig. 2-25). The quartz crystal in conjunction with the first 12AT7 generates an RF signal at the crystal frequency. This frequency may range anywhere from 102 to 125 kc, depending upon the authorized frequency of the station.

The second tube, V_2 , shapes the oscillator buffer output to produce a steeply rising waveform at the crystal frequency, while the third tube, V_3 , is a driven sawtooth generator with a bootstrap circuit to ensure linear rise of the generated waveform. The fourth tube, V_4 , the modulator, clips off the sawtooth wave by an amount varying with the amplitude of the modulating signal impressed on the cathode of this tube.

Prior to its application on the cathode of the modulator, the audio signal is passed through a corrector network and a preemphasis network. The corrector network compensates for the tendency of the high audio frequencies to produce more equivalent frequency modulation than the low audio frequencies.

The preemphasis network is used in the transmitter with a corresponding deemphasis network in the FM receiver. The purpose here is to raise the level of the high audio frequencies to such a degree that they will override noise. That is, it would produce a better signal-to-noise ratio at the receiver.

Referring again to the modulator tube V_4 , the output of this tube is a series of sharp positive pulses at the crystal frequency. The audio information appears in the form of phase modulation of the above-mentioned positive pulses. The effect of the phase-modulated pulses on the grid of the first frequency multiplier tube V_5 is to produce an equivalent frequency modulation.

The audio-frequency amplifier, V_{15} and V_{16} , used on the modulator panel of this transmitter incorporates inverse feedback. The frequency response up to the corrector network is flat between 50 and 15,000 cps. The distortion in terms of total harmonic is less than 1 per cent from 50 to 15,000 cps.

The audio input level is a standard +10 dbm. A potentiometer is provided to change the over-all gain of the amplifier. The +10-dbm input level will produce 100 per cent modulation, which, in this case, is a deviation of ± 75 kc at carrier frequency.

Total frequency multiplication on the modulator panel is 108. The frequency range at the output of this panel is 11 to 13.5 Mc. The available power from the final amplifier stage, V_{14} (type 5686), is approximately 1 watt into 50 ohms.

A second input is provided on the modulator panel by means of which a multiplexed signal can be introduced. A subcarrier generator outside the transmitter under discussion generates a carrier in the frequency range of 25 to 75 kc. The modulation of the subcarrier is FM. The subcarrier is amplified by V_{17} and applied to the main carrier channel in the form of phase modulation. The phase modulation of the main carrier at V_{12} is accomplished by the combination of two quadrature voltages at the output of V_{11} and V_{12} . The grids of these tubes are driven by RF signals that are approximately 90° apart. They combine to form a resulting vector at their common plate load. When subcarrier modulation is applied to the grid of V_{17} , the gain of this tube varies and its output amplitude changes. This new vector which varies in amplitude above and below a static level combines with the fixed amplitude and thus produces phase modulation. The rate and amount of phase modulation is proportional to the multiplex subcarrier frequency and amplitude. When the multiplexing feature of this modulator panel is used, the modulation level of the main channel must be reduced so that the combined modulation of the main program input and the subcarrier input will not produce a total FM deviation greater than ± 75 kc.

Pin jacks are provided on this panel as well as on the frequency-multiplier panel for checking tube voltages. A combination of selector switches and a meter provide metering access to every RF stage in the 250-watt driver. In case of signal failure, the trouble point can be rapidly isolated by means of the selector switch.

As mentioned before, the total frequency multiplication on the modulator panel is 108. A further multiplication of 8 takes place on a frequency-multiplier panel. Three doubler stages and an output amplifier stage complete the panel. The input impedance of the frequency-multiplier panel is 50 ohms. This feature permits inserting a power-monitoring device between panels and checking the RF power. In

addition, the use of a directional coupler for this purpose will give an indication of VSWR and in turn a relative indication of match between units. The normal use of the directional coupler and its power-indicating meter is to monitor constantly the power output of V6011, the 4X250B stage. This equipment as described up to this point occupies one relay rack and can be used as an individual 250-watt FM transmitter.

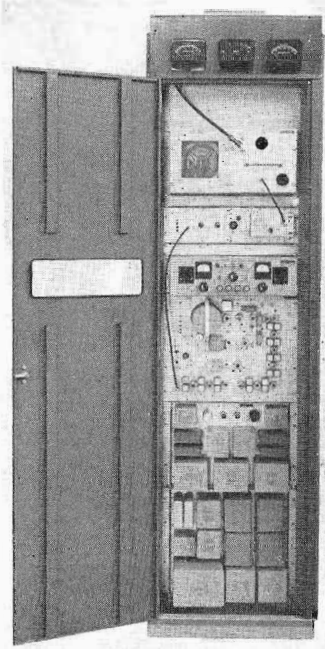

FIG. 2-26. Standard Electronics 250-watt FM transmitter.

It is completely self-contained. It will operate from a 208/230-volt single-phase line. A variable voltage control Transtat³ corrects the line voltage for the entire relay rack to 230 volts for line variations from 187 to 250 volts. The corrected voltage is read on an a-c voltmeter mounted on the control panel. Sufficient capacity has been built into the Transtat in the 250-watt rack to take care of the filament primary requirements of the 3-kw amplifier mounted in a companion relay rack. The 3-kw amplifier, V701 (type 5924A), is a self-contained amplifier mounted in a relay rack 84 by 24 by 22 in.; although it was designed to be a companion unit to the 250-watt transmitter, it can be operated with any low-power transmitter with sufficient drive (see Figs. 2-27 and 2-29b).

The input tuning system, consisting of two tuning stubs separated by an eighth wave, permits the amplifier to work with any driver. The input can be tuned to ideal flatness by means of the directional coupler in the driver or by making use of the coupler supplied with the amplifier.

The output tuning system of the amplifier is a quarter-wave line cavity foreshortened by capacitance. The capacitance plates are ganged and are controlled by a multiturn knob on the front of the cavity. Variable-loop coupling is provided to adjust the loading of the amplifier stage to the antenna system.

A "patch-over" is supplied in this amplifier to facilitate operations in case of amplifier failure.

By means of the patch-over the amplifier can be removed from the RF signal path and the driver connected directly to the antenna. In the patched-out condition, the amplifier can be worked on and, when repaired, can be put back on the air with a minimum of lost air time.

The amplifier is designed for 208/230-volt three-phase a-c operation. The primary side of the high-voltage transformer is supplied with taps to accommodate the differences in line voltage.

Although the input connection is ordinarily made by flexible coaxial line with type H fittings, the same connection can be made with 1 $\frac{1}{8}$ -in. rigid coaxial line. The output connection is made with 1 $\frac{1}{8}$ -in. rigid coaxial line. The patch-over feature previously mentioned is made by means of a U-shaped 1 $\frac{1}{8}$ -in. line located at the rear of the cavity. The physical arrangement of the patch-over includes a Micro Switch⁴ which operates in the patch-out condition. Operation of the Micro Switch permits the amplifier to be worked on while the driver remains in an operating condition.

Another feature of this transmitter is the use of diffused junction silicon diodes as rectifiers in both the high- and low-voltage power supplies. The diodes are arranged on strips of bakelite with banana plugs and jacks to permit rapid replacement of a leg in any rectifier bridge or full-wave application.

³ Registered U.S. Patent Office.

⁴ Registered U.S. Patent Office.

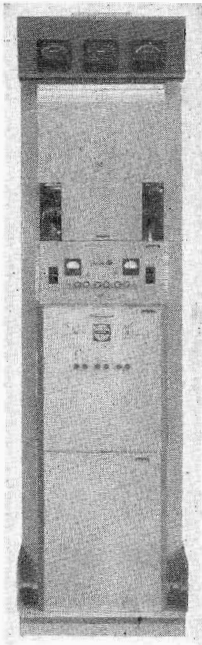

FIG. 2-27. Standard Electronics 3-kw amplifier with skins removed.

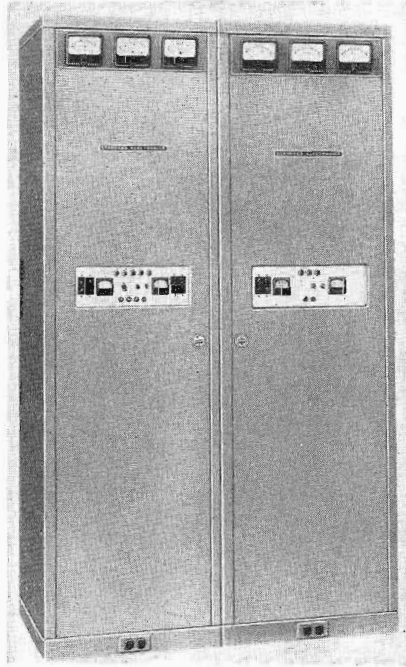
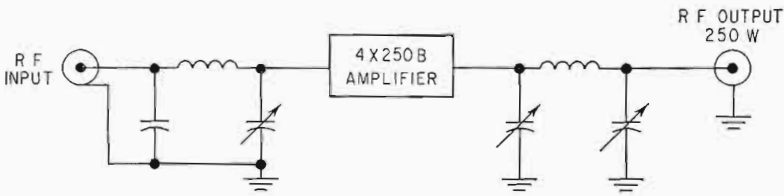
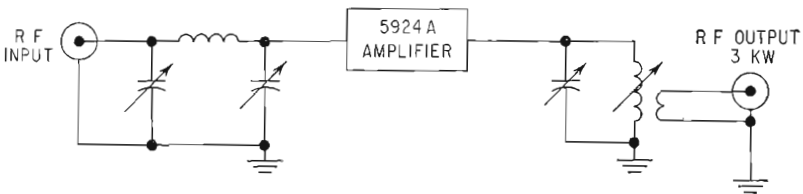

FIG. 2-28. Complete Standard Electronics 3-kw FM transmitter.



(A) 250 W AMPLIFIER



(B) 3 KW AMPLIFIER

FIG. 2-29. Simplified schematic of Standard Electronics 250-watt and 3-kw amplifier.

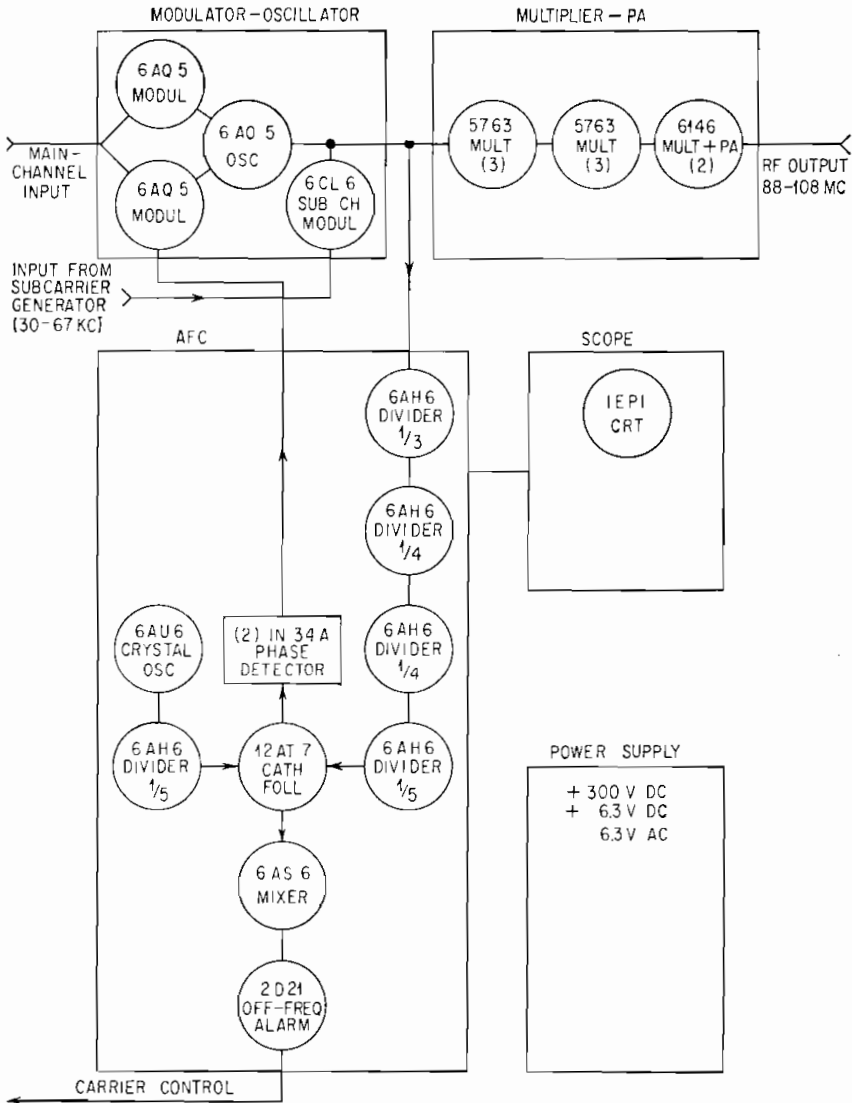

FIG. 2-30. Block diagram of RCA BTE-10B FM exciter.

RADIO CORPORATION OF AMERICA FM TRANSMITTER

The RCA type BTE-10B exciter is used in conjunction with the 250-watt IPA to drive a single 4CX5000A tube in the BTF-5B FM transmitter for ordinary FM service or multiplex operation.

Figure 2-30 is a block diagram of the exciter. A simplified schematic of the modulator-master oscillator portion is shown in Fig. 2-31. A Hartley-type oscillator is used in conjunction with two reactance tubes for the main channel, and a third reactance tube for the modulation of the subcarrier on the main (RF) carrier. This method has several advantages.

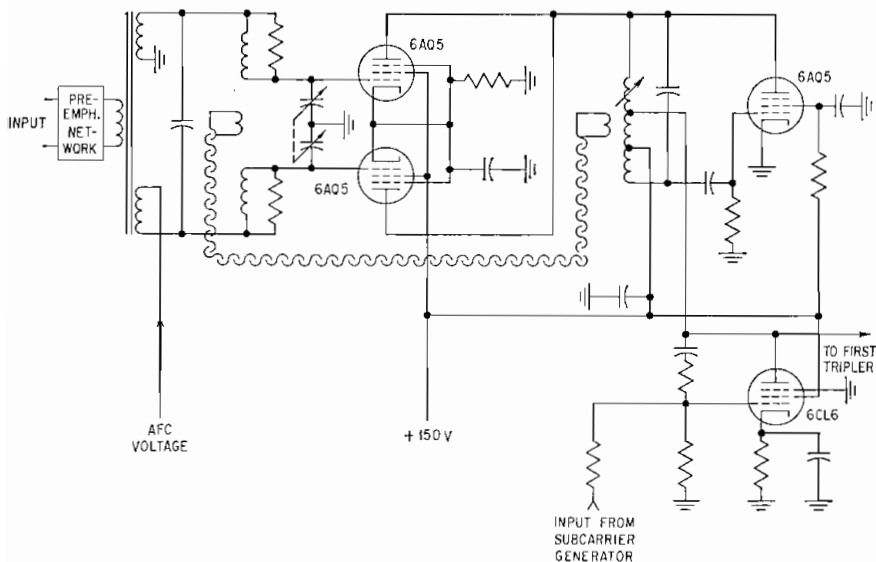

FIG. 2-31. Simplified schematic, oscillator, and modulator.

The highly linear push-pull modulator results in very low harmonic distortion. The coupling circuit is such that each tube is almost a pure reactance, one inductive, the other capacitive. In this way, loading of the oscillator is greatly reduced. The low AFC control voltages required assure proper operation even if the uncontrolled oscillator is off frequency. The subcarrier reactance tube is coupled only to a small part of the oscillator coil, since the deviation of the RF carrier by the subcarrier is small.

Both modulating circuits are very effectively decoupled to minimize the possibility of cross talk between the two channels.

Automatic Frequency Control

Automatic frequency control is accomplished by the use of a phase detector to develop a control voltage that establishes and maintains a phase lock between a reference crystal oscillator and the derived signal. Thus, the system is actually an automatic phase-control system which achieves a stability precisely matching that of the crystal reference source. To confine the phase deviations of the master oscillator signal to within range of the phase detector and in order not to exceed the possible speed of the low-pass network in the AFC circuit, the frequency and swing of the master oscillator must be reduced. This is accomplished in locked-oscillator-type dividers with an over-all division of 240. The maximum phase deviation at the lowest

audio frequency is thus $\pm 28^\circ$ (at ± 100 -kc deviation of the final frequency) and is well within the limits of linearity of the phase detector.

The limited pull-in range normally associated with precise frequency control is overcome by the use of an off-frequency circuit which extends the pull-in range to ± 400 kc (at the final frequency) and simultaneously provides a safeguard against uncontrolled and possible off-frequency operation.

Circuits of the AFC system are diagrammed in Fig. 2-30. A small RF voltage is fed from the master oscillator circuit to the divider chain, where it is divided by 240 to a range of 20 to 25 kc. At the same time, deviation due to modulation is reduced from a maximum of ± 5 kc to ± 20 cps. From the dividers, this voltage is fed through a cathode follower to a phase detector employing two 1N34A diodes. A reference voltage of the same frequency, fed into the phase detector, is obtained by dividing by 5 the frequency of the reference crystal oscillator.

Phase Detector

Operation of the phase detector is illustrated in the simplified diagram shown in Fig. 2-32 and by the vector diagram in Fig. 2-33. Assuming that the master oscillator is exactly on frequency with no correction bias applied to its grid, the two input

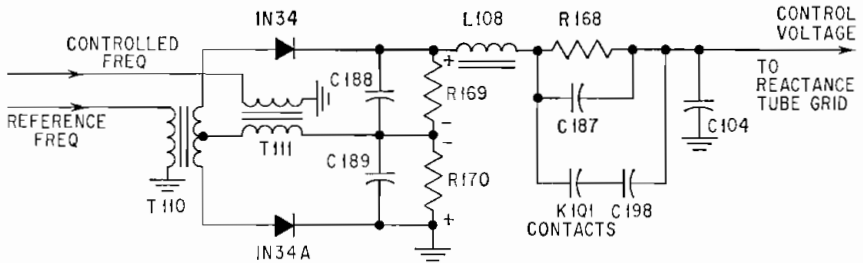

FIG. 2-32. Simplified schematic of phase detector.

signals applied to T_{110} and T_{111} are therefore of the same frequency but 90° out of phase. The reference frequency signal is applied to T_{110} , and the voltage developed across the top half of the secondary is represented by vector BA in Fig. 2-33a, while the voltage across the lower half is represented by vector BC . These two voltages are equal in magnitude and 180° out of phase. The controlled frequency signal is applied to T_{111} , and the voltage developed across its secondary is represented by

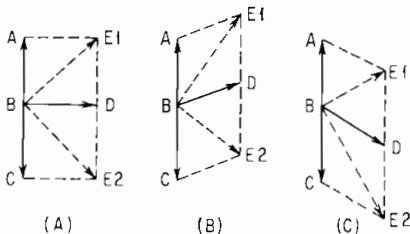

FIG. 2-33. Vector diagram—phase detector.

vector BD , which is 90° out of phase with each of the other two. The voltage impressed across each 1N34A crystal rectifier and its associated load (R_{169} and R_{170}) is then the vector sum of the series voltages E_1 and E_2 , respectively. Since the magnitudes of E_1 and E_2 are equal, the d-c voltages across R_{169} and R_{170} will be equal and of the polarity shown. Hence, the voltage as measured from the top of R_{169} to ground will be zero.

If, however, the frequency of the master oscillator should decrease, the relative phase of the two input signals and their vector relationships will change as shown in Fig. 2-33b.

Since the magnitude of E_1 is now greater than that of E_2 , the d-c voltage across R_{169} will be greater than that across R_{170} , and a net positive correction voltage appearing at the top of R_{169} will be applied to the reactance tube grid, correcting the frequency. Accordingly, if

the oscillator frequency should increase, the vector relationships change as shown in Fig. 2-33c and a net negative correcting voltage is applied to the reactance tube grid. Thus, any departure from the 90° phase relationship between the two signals is instantaneously corrected by a proper error voltage. High-frequency components of the input signals are filtered out of the control voltage by capacitors C_{188} and C_{189} and choke L_{108} .

The network consisting of capacitors C_{104} , C_{187} , and C_{198} and resistor R_{168} extends the control range of the phase detector beyond the $\pm 90^\circ$ phase-difference limit that would otherwise be imposed by feeding a small amount of the beat frequency back to the master oscillator to swing in both directions at the difference-frequency rate. The amount of frequency deviation is proportional to the amplitude of the signal at the

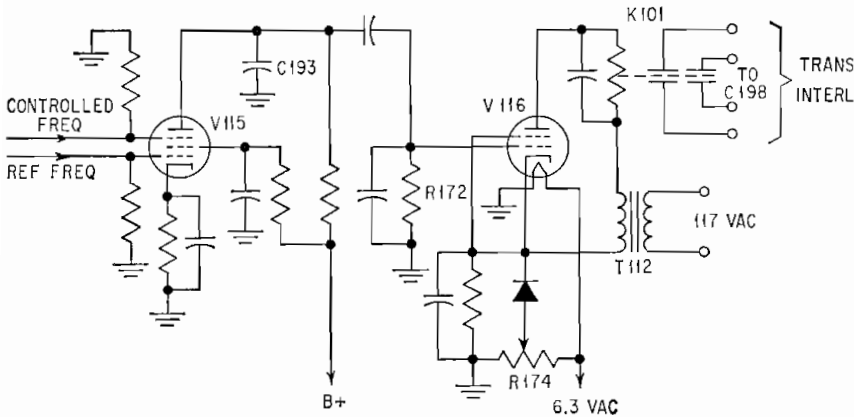

FIG. 2-34. Simplified schematic off-frequency detector.

reactance tube grid, and in order to produce sufficient swing without objectional audio-frequency feedback, capacitor C_{187} is made small and is paralleled by a large capacitor C_{198} , which is switched in only when the master oscillator is "hunting." The switching is done automatically by the off-frequency detector described in a later paragraph.

If the signal at the reactance tube grid is sinusoidal, there will be no d-c component and the mean frequency of the master oscillator will remain unchanged. However, the beat frequency at the phase detector output, when it is not locked in, is nonsymmetrical and has a d-c component of the proper polarity to change the mean frequency of the master oscillator toward its correct frequency.

Protection against loss of control by the automatic-frequency-control system and possible off-frequency operation is provided by the off-frequency detector circuit shown in Fig. 2-34. Tube V_{115} is a 6AS6 mixer stage which is fed from the last divider in each chain as shown in Fig. 2-31. The plate load of the stage is bypassed by capacitor C_{193} , which is a low impedance to the beating frequencies and to the sum of the beating frequencies, eliminating these signals in the output.

When the master oscillator is on frequency, there is no difference frequency produced in V_{115} , and therefore, the output of the stage is zero. If for any reason a difference occurs in the two beating frequencies, however, the difference-frequency component appears across the plate load and hence across the thyatron grid resistor R_{172} . If the positive half of this alternating voltage exceeds the fixed cathode bias applied to the thyatron, V_{116} , the tube conducts, energizing relay K_{101} . One (normally closed) set of contacts on relay K_{101} operates the transmitter interlock circuit, preventing plate power from being applied to the PA; another set of contacts (nor-

mally open) switches in the feedback capacitor C_{198} , shown in Fig. 2-32, for purposes previously described.

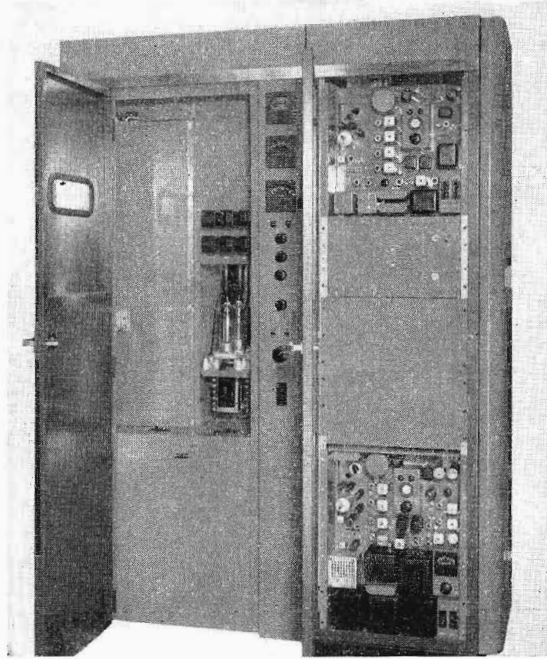

FIG. 2-35. RCA BTF-5B, 5,000-watt transmitter.

The sensitivity of the circuit is adjusted by the thyatron bias resistor R_{174} . This adjustment is set so that the low modulating frequencies will not trigger the thyatron but so that the beat frequencies will cause it to fire.

RF Section

The RF section of the BTF-5B FM transmitter is composed of two high-gain tetrode, Class C amplifiers with the necessary cooling system, power supplies, and control

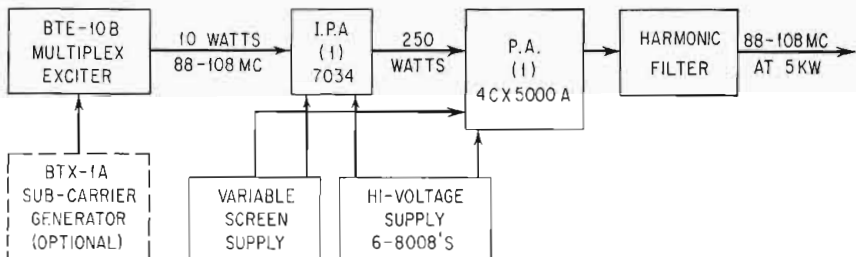

FIG. 2-36. Block diagram BTF-5B transmitter.

circuits to produce the required 5 kw of output power. The complete transmitter, including the BTE-10B exciter, is contained in two metal cubicles with operating

controls and meters on the front vertical panels of the larger cubicle. Space is provided in the smaller cubicle for mounting a multiplex subcarrier generator, type

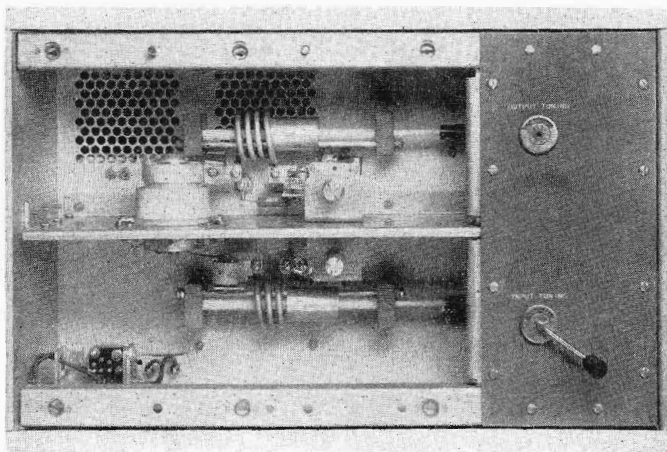

FIG. 2-37. RCA 250-watt intermediate-power amplifier.

BTX-1A. Radio-frequency connections between the exciter and the two RF stages is achieved by using 52-ohm coaxial cable. A variable, common screen supply is used to control power output of both stages, providing an output-power variation of 1 to 5 kw (see Figs. 2-35 and 2-36).

The tetrode IPA circuit consists of two tetrode stages, the first of which uses a 7034 tube located in its own compartment mounted above the exciter (see Fig. 2-37). Both the input and output networks of this stage consist of conventional π networks with variable capacitors as the matching components to match the characteristic impedance of the interconnecting cable (see Fig. 2-38). The frequency variation from 88 to 108 Mc is achieved by varying the inductance. The effective inductance of the coil is reduced by the insertion of a silver-plated brass slug into the center of the coil. No neutralization is required for this stage to achieve an output of approximately 250 watts to drive the PA stage. Both cathode and grid resistance are used to provide grid bias for this IPA stage in such a manner as to prevent excess dissipation when RF drive is removed.

The final stage, the 5-kw PA circuit, uses a 4CX5000A tube located in the larger rack along with the power supplies and the control circuit (see Figs. 2-39 and 2-40). The input circuit to this stage is a modified π network in which the input capacity of the tube is shunted by an inductive line to reduce the effective input capacity of the stage. This inductance also supplies the means for varying the input circuit loading. The inductive component of the circuit is varied by means of capacity in parallel with the coil.

The output circuit of this stage is also a π network with the tube capacity shunted by a variable inductance. Loading and tuning are achieved by the variation of the two inductive-line components. For mechanical simplicity, the π network is inverted, placing one end of the inductance at ground potential. This removes the

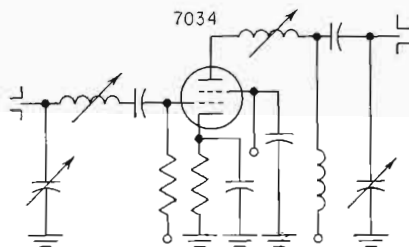

FIG. 2-38. Simplified schematic intermediate-power amplifier.

mechanical and electrical problems of insulating the variable component from ground; however, the output line must be parallel to the inductance to bring it to ground potential. This is done by extending the output line down one side of the inductive line. This stage is neutralized by the variation of the inductance in series with the screen capacity. The efficiency of the final stage is approximately 70 per cent.

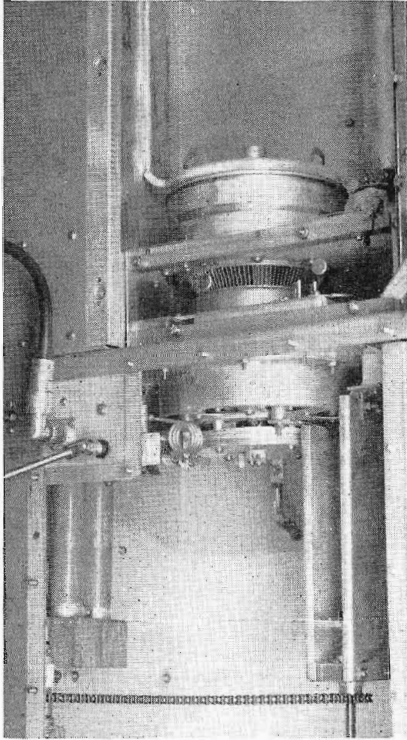

FIG. 2-39. RCA 5,000-watt power amplifier using a 4CX5000.

tuning curves. Final adjustment is then begun under reduced screen voltage for circuit protection.

Tuning to cover the FM range (88 to 108 Mc) requires the changing of only one frequency-determining part in the 4CX5000A input circuit.

Harmonic Reduction

To reduce the harmonics radiating directly from the cabinets, the two power amplifiers are built in shielded compartments. Access doors and panels are equipped with contact fingers to prevent radiation, and all meter and power leads to these compartments enter through feed-through capacitors. The 4CX5000A plate voltage lead was at first bypassed only at the point of exit from its compartment. In order to reduce radiation coming from this lead from a maximum value of 60 db down from carrier to one of at least 72 db, it was necessary to add both a feed-through and ceramic bypass capacitor. Harmonic radiation from the transmitter output is of the order of 38 to 70 db down from carrier and requires the use of a harmonic filter in the output line.

For initial tuning, approximate settings for all variable components are set from

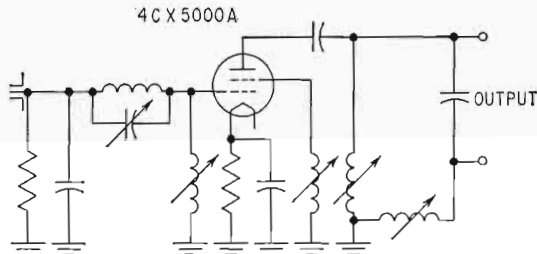

FIG. 2-40. Simplified schematic 5-kw power amplifier.

Control Circuits

The control circuit provides a starting sequence which prevents the application of plate voltage before the filaments are warmed up and the cooling system is operating.

It also provides overload protection and off-frequency shutdown. A time-delay relay of 45 sec provides adequate warm-up time for filaments and exciter. The overload circuit returns the transmitter to the air on the first two overloads after a clearing time of 2 sec. If the overload persists for the third time, manual resetting is required. Overload relays are located in the high-voltage and screen supplies, as well as in the cathode circuits of the IPA and PA stages. The control circuit is designed for unattended operation. By using latching relays in the control circuit all major operations can be remotely operated with a remote-control system, giving momentary closing contacts to the terminals brought out to the transmitter terminal board. In this way the transmitter can be turned off and on, an overload reset, and power output adjusted. Metering resistors provide currents proportional to the final plate voltage and current and power output for remote reading with a 200- μ a meter.

Power Supply

The exciter power supply employs semiconductor rectifiers. One bridge-type germanium rectifier is used for the high-voltage supply, and a full-wave silicon rectifier for the modulator oscillator filament. The exciter can be operated from any single-phase source having a voltage of 197 to 251 volts or 106 to 128 volts a-c at 50 to 60 cps.

One circuit breaker is provided in the high-voltage supply, and one in the a-c input. Both breakers serve at the same time as master and standby switches. There is a separate connection for the 117-volt crystal oven-heater supply. The oven heater should be energized continuously. Each circuit (one operational and one spare crystal) is protected by $\frac{1}{2}$ -amp fuses.

The high-voltage supply is a three-phase, full-wave circuit using six 8008 mercury-vapor rectifier tubes. A single-section inductive input filter produces 5,000 volts at approximately 1.7 amp to supply the plate of the 4CX5000A tube. The center-tap voltage of the transformer supplies the 7034 plate through a double-section RC filter, which filters and reduces the voltage to approximately 1,800 volts. The screen voltage supply uses germanium rectifiers in a bridge circuit to feed both stages. The primary of this transformer is supplied from a variable transformer to control its output voltage.

Three-phase power is applied to the transmitter at the line breaker located on the right-hand front panel of the 5-kw cabinet. Power is then fed to three other breakers. The first supplies power to the filaments, exciter, and control circuit; the second, the high-voltage supply; and the third, the screen supply.

The FILAMENT ON switch applies power to the blower, to the filaments, and to the exciter provided the blower is operating. The filament line passes through a buck-boost circuit so that it can be adjusted to the exact voltage for which the primary filament transformer taps are set. The 45-sec time-delay relay is also energized, preventing the operation of the high-voltage circuit until the time-delay contacts close and all door interlocks are closed. This condition is indicated by the lighting of the READY LIGHT.

The TRANSMITTER ON switch applies the plate and screen voltage to the two tetrode stages. This is indicated by the lighting of the TRANSMITTER ON light. A motor-controlled variable transformer in the screen-supply line adjusts the screen voltage by means of the PROPER ADJUST switch.

Cooling System

The cooling-system blower is located in the bottom of the 5-kw cabinet, feeding air directly into the 4CX5000A stage. A constant-speed blower is used which will deliver enough air to cool the final tube up to an altitude of 7,500 ft. The air for the 7034 stage is tapped off the side of the 4CX5000A box by means of a flexible tubing that feeds through the side of the cabinet. Air interlocks are provided in both stages to remove plate and screen voltage if the air should stop.

Performance Data

In conventional FM service (meaning the transmission of only one program on the RF carrier and no subchannels) there are mainly three transmitter-design considerations which affect performance: (1) frequency response, (2) harmonic distortion, and (3) the ratio of the wanted signal to the unwanted noise (signal-to-noise ratio,

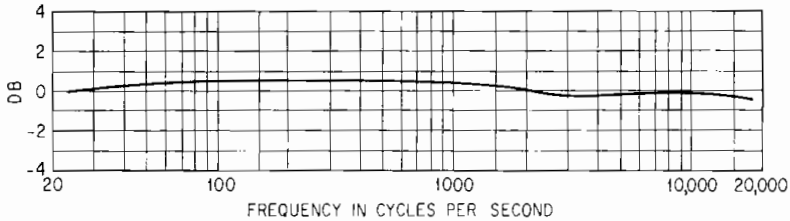

FIG. 2-41. Typical frequency response.

or S/N). Cross talk between channels would have to be added when a multiplex system is considered.

Typical performance data for frequency response are given in Fig. 2-41. Performance is measured from 50 to 18,000 cps. The frequency response of the transmitter is mainly determined by the quality of the audio-frequency components used in the modulator section of the exciter. The RF circuits following the reactance tube modulator and the master oscillator have no appreciable effect on frequency response. The exciter needs only three tuned stages to get up to the final output frequency in the FM broadcast band.

Nonlinearities of the phase-vs.-frequency curve of the tuned circuits create harmonic distortion. The degree of distortion depends upon the degree of nonlinearity. The

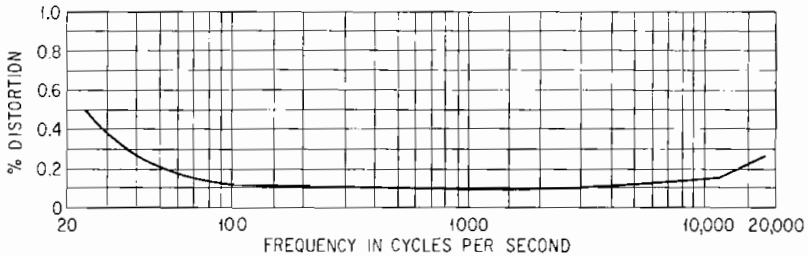

FIG. 2-42. Typical distortion characteristic.

distortion can differ greatly at different audio frequencies, and it is, of course, dependent on the percentage of modulation. To a lesser degree, distortion is also created by improper amplitude response of the tuned circuits, but under practical conditions this can be disregarded. It should be remembered that in order to get the *ultimate* of low-distortion output from any FM transmitter (or receiver), all tuned stages should be tuned for minimum distortion, employing a distortion analyzer as an indicating device.

Figure 2-42 gives typical performance data of a BTF-5B transmitter for harmonic distortion. The distortion is so low that the limit of accuracy of the measuring device is of the same order of magnitude.

The AM noise level is -57 db with reference to the carrier voltage, and the FM noise level is -69 db.

Coupled with RCA's new broadband FM antennas, the BTF-5B transmitter can provide effective radiated powers from 4 to 60 kw. The entire chain meets all current FCC and industry standards.

Part 3

TV BROADCAST TRANSMITTERS

J. T. TILLMAN

*Broadcast Transmitter Engineering
Communications Products Department
General Electric Company
Electronics Park
Syracuse, New York*

INTRODUCTION

Once a television scene has been reduced to an electrical signal with the necessary synchronizing information included for proper reproduction, it becomes necessary to deliver the composite signal to the receiver in the home. It is customary to take the composite signal and send it out as high-frequency electromagnetic information to be received and decoded by a television receiver.

In order to eliminate the confusion of signals which would occur if there were no control or regulation of what frequencies to use for television transmission, the government, through the Federal Communication Commission, has set up certain rules and regulations for governing the service.

From a study of the Federal Communications Commission's Rules and Regulations, it is seen that the visual portion of the signal is an amplitude-modulated RF signal while the aural signal is a frequency-modulated RF signal. Because of the great demand for portions of the frequency spectrum, the FCC has set aside many television channels of 6-Mc bandwidth. The visual and aural signals must fit into the 6-Mc bandwidth with their carrier frequencies separated by 4.5 Mc. Because of the different types of modulation and the slightly different frequencies required, it has become the practice to use separate transmitters for the aural and visual signals, with the over-all transmitter power rating being the synchronizing peak power of the visual transmitter. The aural-transmitter power rating must be from 50 to 70 per cent of the visual synchronizing peak power.

For convenience of discussion the composite transmitter will be divided into the visual transmitter, the aural transmitter, the rectifiers and regulated power supplies, and the control circuitry.

VISUAL TRANSMITTER—BASIC CIRCUITRY

The visual transmitter can be broken down into the various functional parts shown in Fig. 3-1.

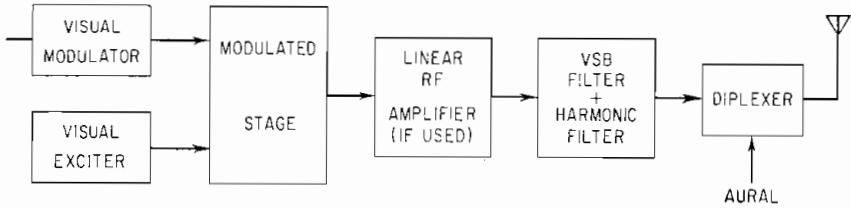

FIG. 3-1. Block diagram—visual transmitter.

Visual Modulators

The prime purpose of the visual modulator is to take the composite video signal of approximately 1 volt peak to peak and amplify it to a level sufficient to modulate the visual RF carrier and to establish a d-c reference to control the modulation of the RF in direct relation to the brightness level of the video signal.

The following factors must be considered in any visual modulator:

1. Input signal level. At least 0.8 volt for full modulation, with the modulator continuing to operate on signals as small as 0.5 volt peak to peak.
2. Signal output to modulated stage. Dependent upon tube and method used for modulation, with grid modulation being the most common and thus requiring synchronizing positive output.
3. Load impedance. Usually highly capacitive.
4. Bandwidth. Usually in excess of 6 Mc to assure minimum time delay of the high-frequency picture detail referred to the low-frequency information.
5. Direct current insertion. This is the d-c level of the signal blanking and is a function of the modulation method and the tube in which modulation takes place.
6. Additional features. Synchronizing pulse stretch, white clip, and linearity-correction circuits.

Since the video amplifiers are the most important parts of the visual modulator, special attention should be given them in the original design to assure optimum performance. With several video amplifiers in series, it is best to assure a uniform over-all amplitude-vs.-frequency response by designing with excessive bandwidth, using the equations for maximum flatness. The extra bandwidth eliminates bandpass limitation from cascading stages and assures a uniform time delay through the amplifiers of the critical frequencies. A bandwidth per stage of 7 Mc is a reasonable design figure for a visual modulator.

Most video amplifiers in present-day modulators employ pentodes and can be designed using equations based on a simple uncompensated stage (see Fig. 3-2). From an inspection of Fig. 3-2*b* it is seen that the amplitude of the output signal will fall off at both the high frequencies and the low frequencies owing to the shunt

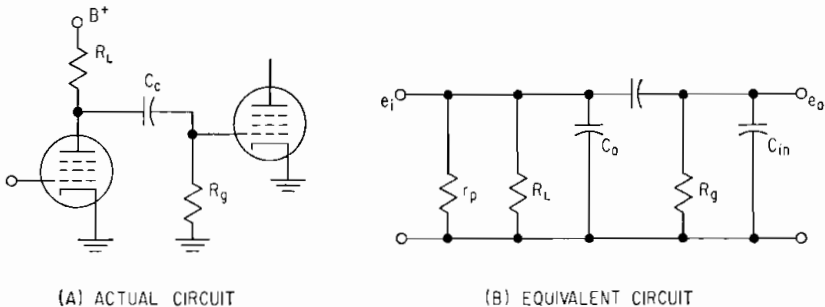

FIG. 3-2. Typical video amplifier—uncompensated.

capacities and the coupling capacitor, respectively. Figure 3-3 shows Fig. 3-2b further simplified.

Since there are two distinct regions of the simple video amplifier passband which suffer attenuation, two methods of compensation are necessary.

For convenience, consider the equivalent circuit of a pentode amplifier shown simplified in Fig. 3-3. Figure 3-3a shows that the load impedance is simply R_L and

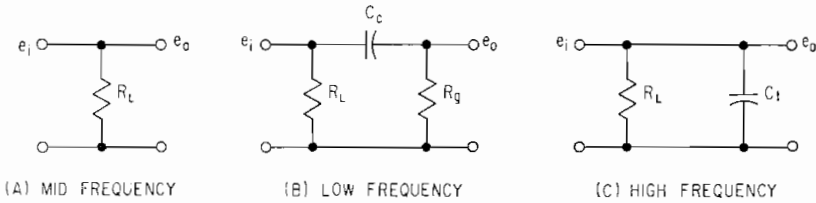

FIG. 3-3. Equivalent circuits of Fig. 3-2b.

as such is called the mid-frequency case, that case in which both low- and high-frequency attenuation effects can be neglected. Therefore, the gain of this amplifier is simply

$$\text{Voltage gain} = g_m R_L$$

As the information frequency passing through the amplifier is decreased, the coupling capacitor impedance increases, allowing less and less signal voltage to reach the grid of the next tube. In practice, R_g is made as large as the tube will allow, generally 0.5 megohm, while the coupling capacitor is usually made about 0.5 μf . Then, referring to Fig. 3-3b, it is seen that the low-frequency gain is

$$\text{Voltage gain} = \frac{g_m R_L R_g}{R_L + R_g - X_{cc}}$$

If it is decided to extend the low-frequency response, a form of low-frequency compensation can be incorporated which tends to counterbalance the term

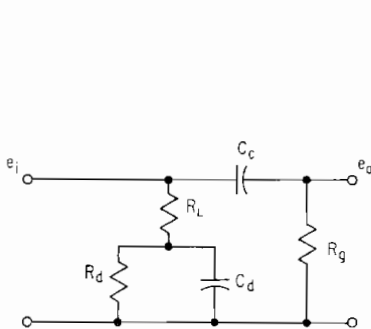

FIG. 3-4. LF compensated equivalent circuit.

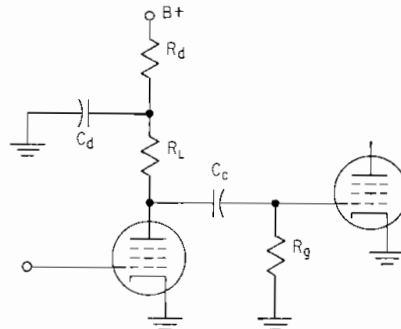

FIG. 3-5. Practical circuit of Fig. 3-4.

$R_g/R_L + R_g - X_{cc}$. The equivalent circuit of Fig. 3-4 appears as a slightly modified circuit as shown in Fig. 3-3b. Optimum results are obtained if

$$\frac{R_d R_L}{R_d + R_L} C_d = R_g C_c$$

As the information frequency passing through the amplifier is increased, the shunt capacity C_i of Fig. 3-3c steadily decreases the total load impedance, resulting in the gain of the amplifier decreasing with increasing frequency. The obvious approach to improve the bandwidth is to use low-capacity tubes and to minimize wiring capacities, but when this approach has been exhausted, the following forms of high-frequency compensation can be used.

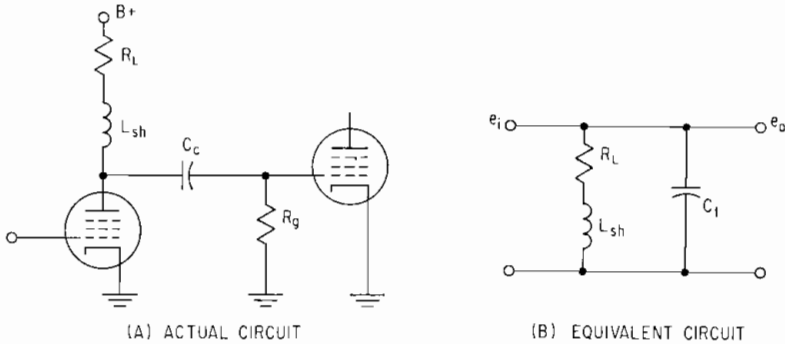

FIG. 3-6. Shunt compensation.

For a moderate amount of bandwidth extension, shunt compensation is commonly used as shown in Fig. 3-6.

As a compromise between maximum flatness and uniform time delay,

$$L_{sh} = \frac{0.44R_L}{W_h}$$

where L_{sh} = shunt peaking inductance

R_L = load resistance

W_h = 3-db point on high-frequency side of uncompensated amplifier

A second form of high-frequency compensation, called series peaking, is shown in Fig. 3-7. While a great deal of trial and error is used in the selection of the correct value of L_{se} , the following design equations can be used as an approximation:

$$L_{se} = 0.67C_iR_L^2$$

$$R_L = \frac{1.5}{W_hC_i}$$

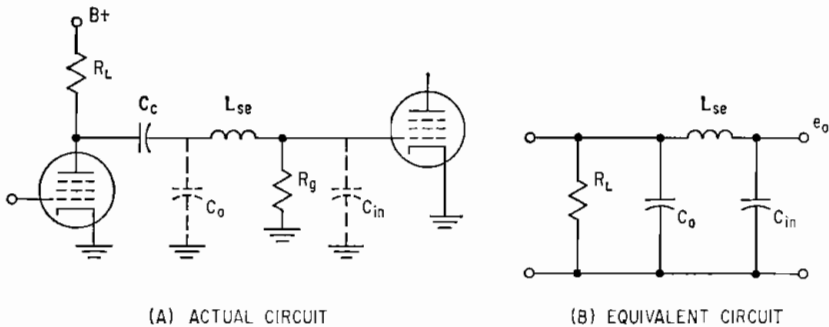

FIG. 3-7. Series peaking compensation.

where

$$C_{in} = 2C_o$$

where C_o = plate output capacity of amplifier

C_{in} = grid input and wiring capacity of next stage

$$C_t = C_o + C_{in} + C_{wiring}$$

A third method of compensation is a combination of both shunt and series peaking and takes the form shown in Fig. 3-8. This form also takes some trial-and-error selec-

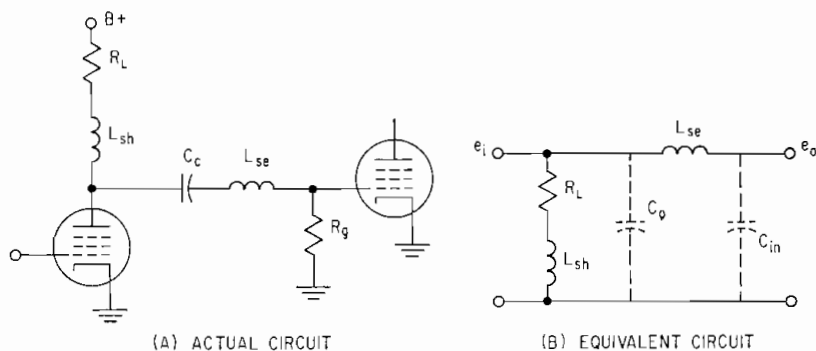

FIG. 3-8. Series shunt compensation.

tion for the proper component values, but the following design equations can be used for a good approximation:

$$R_L = \frac{1.8}{W_h C_t}$$

$$L_{sh} = 0.12 C_s R_L^2$$

$$L_{se} = 0.52 C_t R_L^2$$

where $C_t = C_o + C_{in} + C_{wiring}$

L_{sh} = shunt peaking inductance

L_{se} = series peaking inductance

R_L = equivalent load resistance

W_h = 3-db point on high-frequency side of uncompensated amplifier

While there are other forms of video compensation used either to increase the amplifier bandwidth or to increase the gain for a given bandwidth, the above forms of compensation are the most commonly used. At all times, component layout and lead length of interconnections are important and to a degree determine the final component values used in the compensated amplifiers. In practical amplifier circuits the peaking coils are generally made variable to compensate for variations occurring in circuit capacities between various units being manufactured.

Once the video amplifiers have been used to obtain the desired voltage gain and signal polarity, the signal must be sent to the modulated stage. Since most modulated stages have high input capacitance, the modulator output stage must be capable of operating into large values of capacitance while supplying a video signal unhampered by whatever grid conduction takes place in the modulated stage.

Although an anode follower is sometimes used when no grid conduction of the modulated stage occurs, some form of cathode follower is generally used. For relatively small signal outputs a simple cathode follower is used, but with large output signal requirements a more elaborate circuit is required. The circuit shown in Fig. 3-9a is commonly used. For the lower frequency components of the signal, the circuit of Fig. 3-9a acts like a simple cathode follower as in Fig. 3-9b. For the high-fre-

quency components of the signal, when C_{in} has difficulty discharging on the negative portion of the cycle, the circuit appears as that shown in Fig. 3-9c.

One way of analyzing the action of the stage is to consider that the circuit is acting as a cathode follower for low frequencies and as a switching circuit for high frequencies. For positive-going signals, V_1 of Fig. 3-9 charges C_{in} at a rapid rate, and for

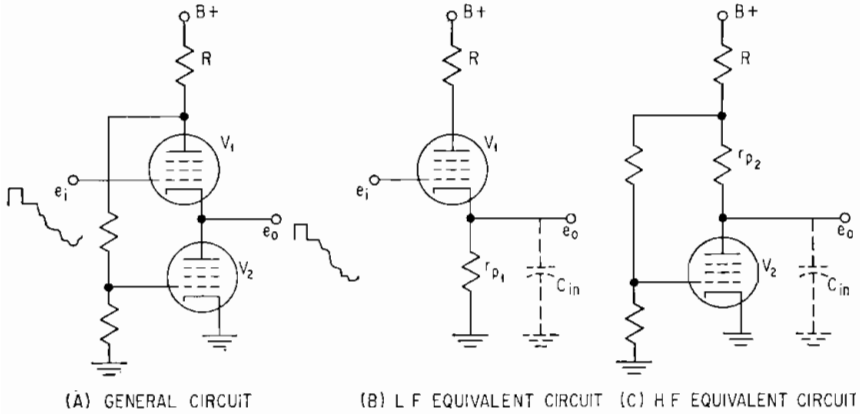

FIG. 3-9. A modulator output stage.

negative-going signals, V_1 acts as a high impedance. A signal sampled from R to the grid of V_2 , however, is positive and switches V_2 into heavy conduction to discharge C_{in} at a rate rapid enough to keep pace with the output signal. For purposes of gain determination, the circuit gain of a simple cathode follower can be used, meaning that the maximum voltage gain approaches unity.

In addition to the modulator requirement of amplifying the video signal and sending it to the modulated stage, there is also the requirement of inserting a d-c component into the signal. This d-c insertion is required, since the pedestal level and

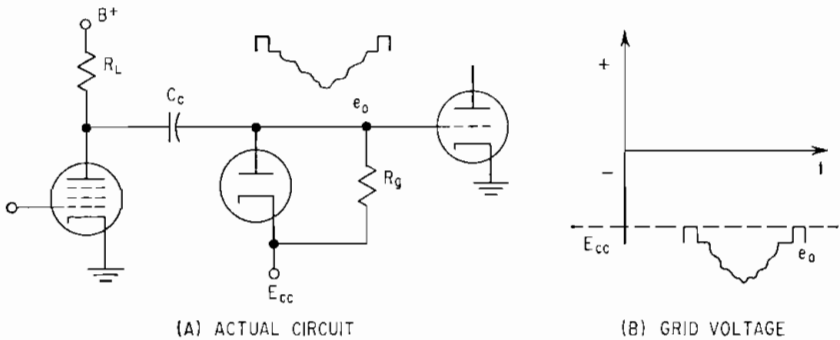

FIG. 3-10. Diode clamp.

the synchronizing peak level must remain at constant power output levels regardless of signal content (whether mostly black or mostly white picture). Since a d-c component is necessary, there are two commonly used methods of inserting direct current. The most simple method is that of using an ordinary diode clamp as shown in Fig. 3-10. Referring to Fig. 3-10, the grid of V_2 is always biased to $-E_{cc}$ through re-

sistor R_g . Each time the signal attempts to go more positive than $-E_{cc}$, the plate of the diode tends to become more positive than its cathode and conduction occurs; this causes the diode to appear as a short circuit and causes the synchronizing peak to always be at $-E_{cc}$. The ability of this clamp to hold synchronizing peak at $-E_{cc}$ under all conditions of signal content is limited by the diode impedance under con-

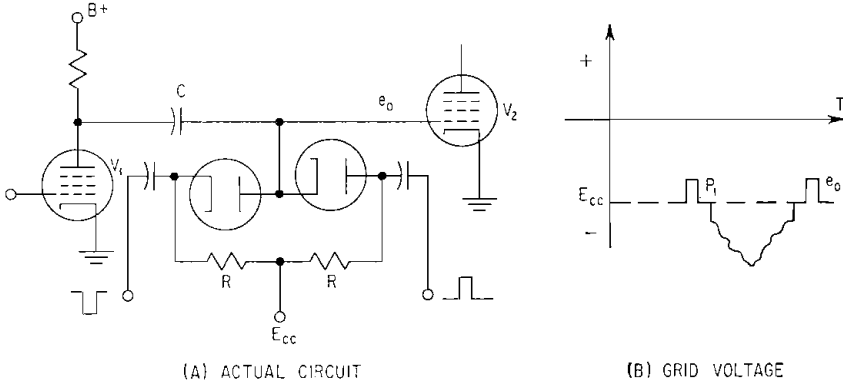

FIG. 3-11. Keyed clamp.

duction. Generally, some degradation occurs in the vertical interval pulses because the energy content is different from the energy of the horizontal synchronizing pulses.

A second type of clamping circuit commonly used for establishing a d-c reference on the composite video signal is called a driven or keyed clamp and is shown in Fig. 3-11.

The circuit shown in Fig. 3-11 consists of a dual diode arranged in a balanced-bridge circuit. At the instant the two keying pulses occur, the two diodes are forced into conduction, placing the grid circuit of V_2 at $-E_{cc}$ during the clamping interval. Once the clamping or keying pulses have ceased, the video signal is free to travel in both a positive and a negative manner about E_{cc} . This clamping is usually set to

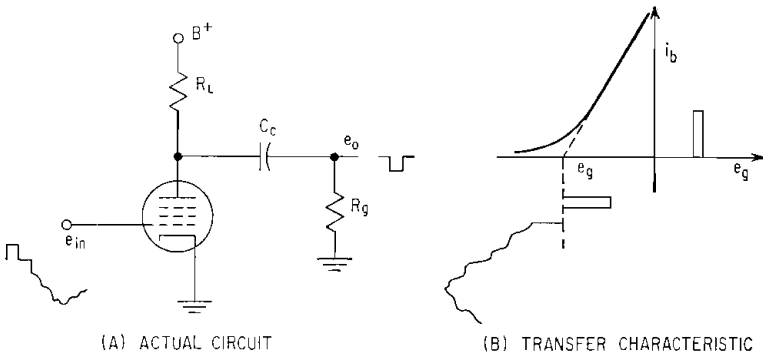

FIG. 3-12. Sync separator.

occur at P_1 , which is the back porch of each horizontal synchronizing pulse, and this ensures a solid clamping action regardless of signal content (whether all white or all black).

In order to use the keyed clamp circuit of Fig. 3-11, keying pulses must be generated. This generation is usually accomplished by using standard synchronizing

pulses derived from the video signal, using a synchronizing pulse-separator circuit such as that shown in Fig. 3-12.

Once the synchronizing pulses have been derived from the composite signal, as shown in Fig. 3-12, the keying pulses are generally derived by either of two methods: a differentiating circuit or a shorted delay line. Figure 3-13 shows a differentiating circuit for deriving keying pulses.

Referring to Fig. 3-13, it is seen that both a negative and a positive spike are obtained from the differentiating circuit, and either can be used for keying pulses. The

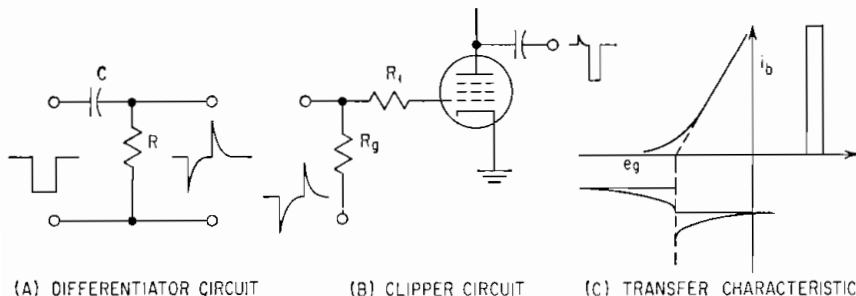

FIG. 3-13. Differentiator key derivation.

first spike can be used for clamping on synchronizing peak, while the second can be used to back porch clamp and is used more commonly in present-day operation. The simple limiter of Fig. 3-13 is biased so that the first spike is below cutoff and is thus discarded, while the second pulse is limited by R_1 when grid current tends to flow, resulting in a keying pulse.

Figure 3-14 illustrates another method of obtaining keying pulses from synchronizing pulses. A shorted delay line acting as a reflecting circuit gives both a positive and a negative pulse equal in width to twice the electrical length of the delay line. In practice, the delay line has an electrical length between 0.5 and 1 μsec , resulting in a keying pulse width from 1 to 2 μsec . A limiter similar in nature to that of Fig. 3-13b is used to select the desired pulse. The advantage of this method is that it takes less signal voltage to derive the keying pulses than the differentiator circuit of Fig. 3-13a and is less sensitive to tube-capacity and signal-level changes.

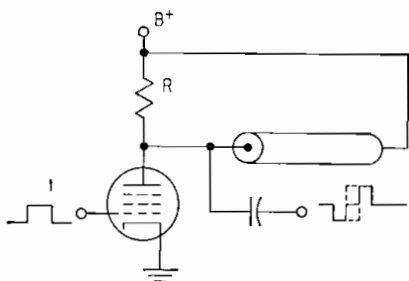

FIG. 3-14. Shorted delay line key derivator.

As an added feature, some transmitters have incorporated in the visual modulators white clippers that limit the depth of modulation in order to prevent inter-carrier noise resulting from overmodulation. The circuit of Fig. 3-15 is typical of white-clipper circuits. Whenever the plate voltage of Fig. 3-15b goes below E_1 , the diode ceases to conduct, preventing e_0 from going more white and effectively limiting the depth of visual modulation.

For purposes of increasing the over-all linearity of the transmitter, black-and-white stretchers are sometimes incorporated in one of the video amplifiers of the visual modulator. The circuit shown in Fig. 3-16a is commonly used.

In general, R_k furnishes degeneration for the stage. When e_k goes to a voltage below E_1 , CR_1 conducts, causing the effective cathode resistance to be reduced, resulting in less circuit degeneration and higher voltage gain. Likewise, when e_k goes

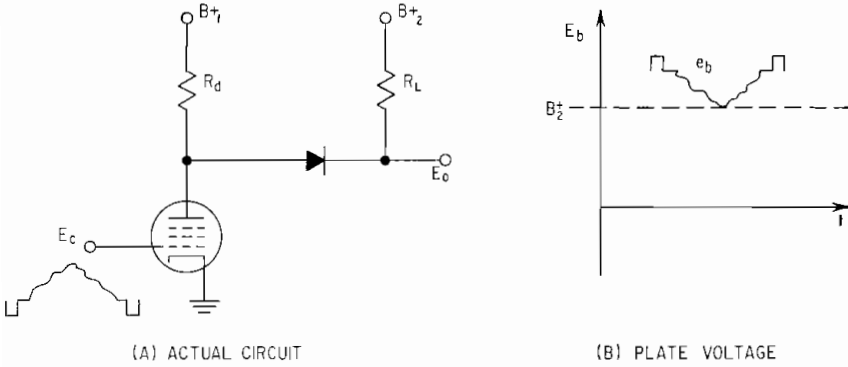

FIG. 3-15. White clipper.

above E_2 , CR_2 conducts again, reducing the degeneration. The plate output signal appears as the e_0 waveform of Fig. 3-16a with the stretching having occurred on the shaded areas.

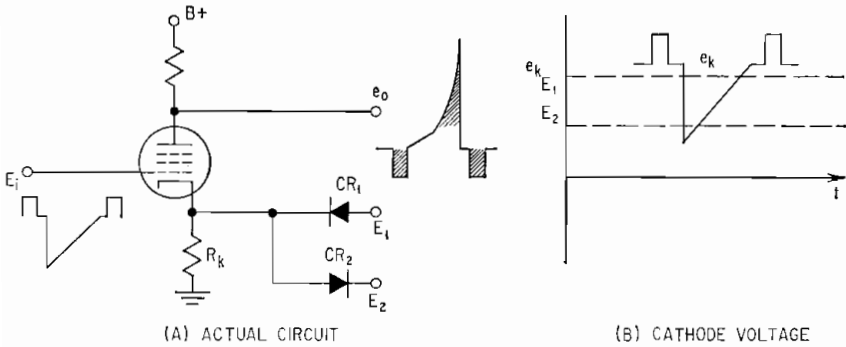

FIG. 3-16. Stretcher circuits.

Visual Exciter

The visual exciter supplies the carrier-frequency signal to the modulated stage at the proper frequency and at the necessary power level.

Because of the accurate frequency control necessary to meet the FCC requirements on the frequency stability, the oscillator generating the frequency will be crystal-controlled and it can be similar to the Colpitts oscillator shown in Fig. 3-17.

It is common practice to make the crystal-controlled oscillator function at some submultiple of the final frequency and then to frequency-multiply to arrive at the final carrier frequency. For Channel 2 operation, where the visual carrier frequency is 55.25 Mc, a frequency-multiplication factor of 12 has been used, necessitating a crystal-oscillator operation at precisely 4.60417 Mc. The indicated precision is necessary, since the crystal tolerance must be

$$\begin{aligned} \text{Crystal tolerance} &= \frac{\text{FCC tolerance}}{\text{multiplication factor}} \\ &= \frac{\pm 1,000 \text{ (FCC tolerance)}}{12} = 83.3 \text{ cps} \end{aligned}$$

This 83.3-cps tolerance must include all sorts of drift such as that which arises from temperature changes and short-term variations of the crystal.

Once the fundamental frequency has been generated, there remains the problem of multiplication. If the required multiplication is 12, then two doublers and a tripler will be necessary.

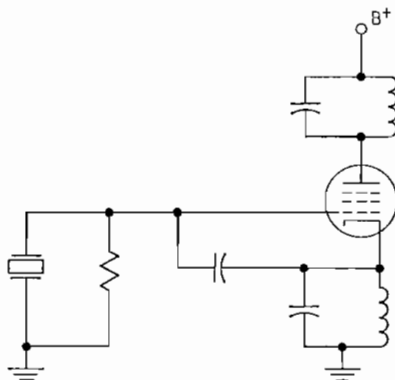

FIG. 3-17. Visual exciter crystal oscillator.

As seen in Fig. 3-18, multiplication results in the generation of many frequencies. To prevent the appearance of undesired frequencies, the multiplier stages should have highly selective tuned-circuit elements. These tuned-circuit elements often take the form of double-tuned inductively coupled circuits for maximum selectivity, and they are generally tuned and coupled for a condition slightly less than critical coupling.

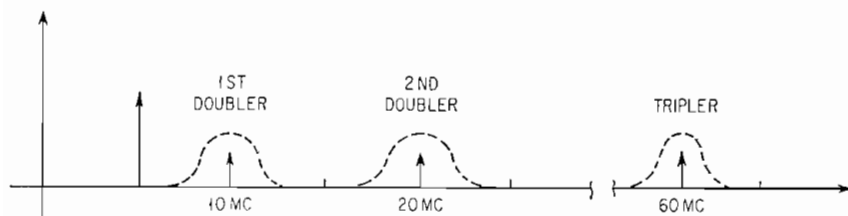

FIG. 3-18. Frequency-multiplication spectrum.

Once the proper carrier frequency has been obtained, there remains the task of amplifying the carrier signal to the level required by the modulated stage. Class C amplifiers are used for the amplification, with the necessary c-w power being a function of the type of modulation used and the level of modulation.

Modulated Stage

The modulated stage is one of the most important parts of the visual transmitter, since it must perform the function of converting the video signal to an amplitude-modulated RF signal with a minimum of amplitude or phase distortion. Although various methods have been used for modulating the visual transmitter, practice has settled on grid modulation for best performance, with either low-level or high-level modulation being used.

Low-level modulation deals with low-level signals and takes the form of square-law-type modulation or power modulation operating at a low power output. When low-level modulation is used, it is necessary to have several stages of wideband amplification in order to arrive at an output power which is useful in commercial

operation. This requirement of several stages of power amplification must be balanced against the savings made in lower power visual modulators and exciters.

The square-law-type modulator can best be understood by reference to Fig. 3-19, which shows both the general circuit configuration and the transfer characteristic. From the general circuit configuration it is seen that the grid signal is composed of both video direct current coupled from the visual modulator and the carrier signal alternating current coupled from the visual exciter. The grid signal is essentially a low-level RF signal together with a slowly varying bias consisting of the video signal. The stage then acts as a Class A RF amplifier. Since the transfer characteristic is nonlinear, the gain will not be a constant but will be a function of the bias or of the

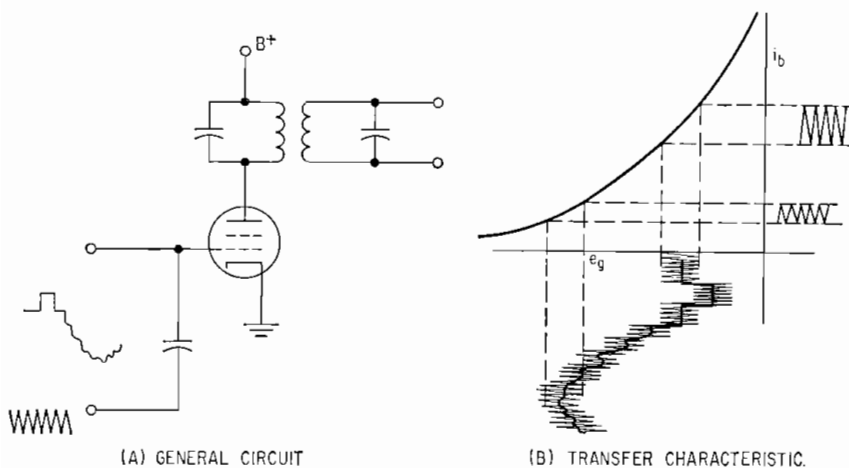

FIG. 3-19. Square-law-type modulation.

video signal. For the proper degree of modulation the circuit shown must have a linear gm variation of 10 to 1 between synchronizing peak and reference white, since the RF voltage gain of the stage is

$$\text{Voltage gain} = gmZ_L$$

where gm = transconductance

Z_L = load impedance

A power-modulated stage is similar to the modulated stage shown in Fig. 3-19, except that it operates on the assumption of a linear transfer characteristic. The general circuit is that shown in Fig. 3-20a, with the transfer characteristic shown in Fig. 3-20b.

Again, the grid signal consists of an RF signal a-c coupled from the visual exciter and a slowly varying bias voltage which is the video signal d-c coupled from the visual modulator. In this case, the video voltage generally has a peak-to-peak amplitude equal in magnitude to the projected cutoff bias voltage, with a d-c reference

$$\begin{aligned} E_{cc} &= \text{d-c insertion} - E_k \\ &\cong 1.3E_{\text{cutoff}} - E_k \end{aligned}$$

where E_k = cathode voltage of pedestal level

d-c = pedestal insertion voltage from visual modulator

The RF level is such that the peak-to-peak RF is at least twice the peak-to-peak video level, or

$$\begin{aligned} \text{RF voltage} &\geq 2E_{\text{video}} \\ &\geq 2E_{cc} \end{aligned}$$

As seen in Fig. 3-20*b*, the stage operates as a simple Class B RF amplifier at the synchronizing peak level and as a Class C RF amplifier at the reference white level, resulting in an RF signal output linearly amplitude-modulated according to the grid video signal. Since the transfer characteristic is not linear near the cutoff region, an improvement in linearity can be had by using some cathodic video degeneration.

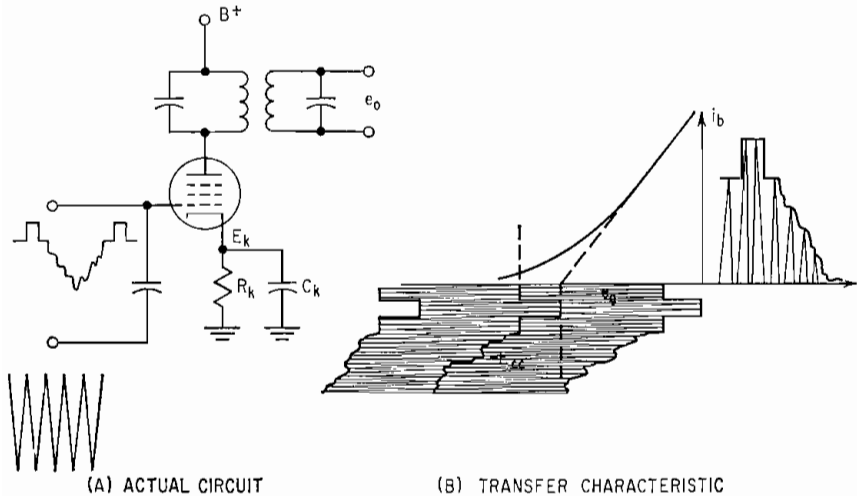

FIG. 3-20. Power modulator.

In general, most tubes used in modulated stages require a grid circuit which has a frequency response at least twice that of the modulating frequencies. This requirement becomes a necessity as grid conduction takes place.

Neutralization is extremely important, since the possible depth of modulation is affected by the feed-through RF, thus influencing the modulation linearity and the differential phase shift.

Wideband and RF Amplifiers

In order to transmit the required frequency components of a television signal, the RF circuits through which the modulated RF signal passes must be wideband to pass the modulating frequencies uniformly out to at least 4.2 Mc.

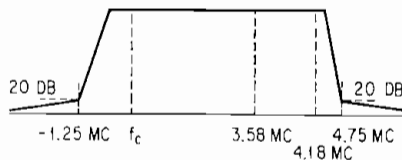

FIG. 3-21. FCC bandpass.

The bandpass of Fig. 3-21 shows the requirement of the FCC and serves as a guide for wideband-amplifier design.

From an observation of Fig. 3-21 it is seen that the required RF bandpass is approximately 5 Mc wide. This required bandwidth and the tube capacities usually determine what power output can be obtained from a given tube. Since the majority of wideband amplifiers used in television transmitters employ double-

tuned circuits, the equation of Fig. 3-22 relates the bandwidth and the tube capacities to the effective load impedance for slightly overcoupled circuits.

Once the effective load impedance that is realizable from the proper consideration of the tube capacities and the bandwidth needed is known, it is possible to estimate the tube power capabilities on the basis of a Class B RF tuned amplifier. The con-

stant-current curves are generally most useful for determining the tube operation (Fig. 3-23).

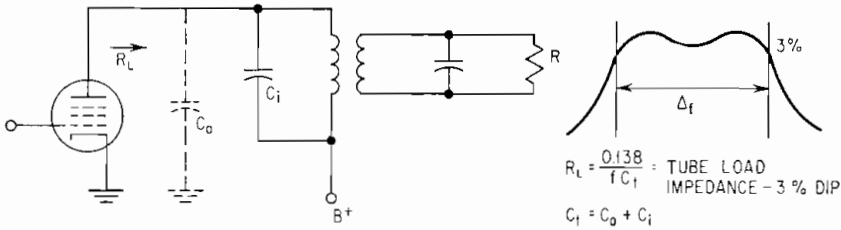

FIG. 3-22. Double-tuned circuit.

Based on the assumption of a Class B linear circuit with the plate current flowing in half-wave-rectified sine waves, the following equations hold as a first approximation:

$$P_{out} \cong \frac{(E_{bb} - E_{min})I_{max}}{4} \quad \text{assumes negligible idle current}$$

$$P_{outS.P.} \cong \frac{(E_{bb} - E_{minS.P.})I_{maxS.P.}}{4} \quad \text{point } A \text{ sync peak power output}$$

$$P_{outP.L.} \cong \frac{(E_{bb} - E_{minP.L.})I_{maxP.L.}}{4} \quad \text{pedestal level power output}$$

$$I_{avg} \cong I_{max}$$

$$R_{eff} \cong \frac{2(E_{bb} - E_{min})}{I_{max}}$$

As a general approximation, the rated plate dissipation of a given power tube can be used as an indication of the power-output capability. In wideband operation of 5 Mc, the synchronizing peak output-power capability is approximately equal to the rated plate dissipation for most tubes used in VHF transmitters.

The above method of approximating the tube operation can be used for both the modulated stage and any subsequent RF linear Class B amplifiers. If a more accurate and detailed analysis of the tube operation is desired, resort must be made to an exact method of graphical calculation, which takes into account tube nonlinearities.

Output Circuits

Once the tube circuitry associated with the visual transmitter has been determined, there remains the job of shaping the bandpass to conform to the FCC requirements of adjacent channel interference. The important items are a vestigial-sideband filter, an upper sideband filter, and a harmonic filter, together with a diplexer if separate antennas are not used.

The purpose of the vestigial-sideband filter is that of limiting the lower sideband of the transmitter in order to ensure 20 db of attenuation at frequencies of $f_c - 1.25$

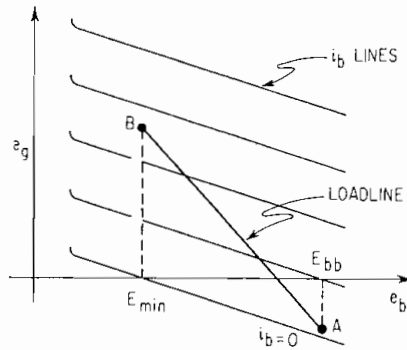

FIG. 3-23. Typical constant-current curves.

Mc and below. In general, there are two basic types of VSB filters used: constant impedance and nonconstant impedance.

The most simple VSB filter mechanically, and therefore the more economical, is the nonconstant-impedance type, which is usually a transmission-line trap. The equiv-

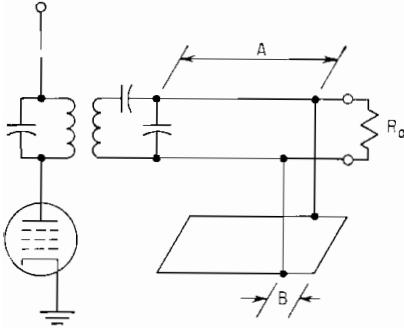

FIG. 3-24. Nonconstant-impedance VSB filter.

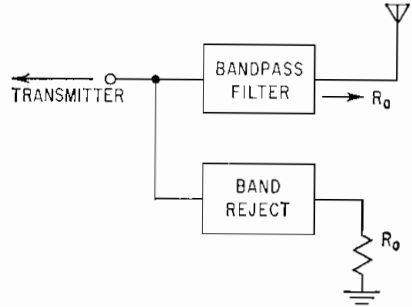

FIG. 3-25. Constant-impedance VSB filter.

alent circuit is shown in Fig. 3-24, and the filter must be tuned in conjunction with the preceding double-tuned circuit of the output tube. Briefly, the trap in the transmission line acts as a sharply tuned trap to form the sharp rate of attenuation shown in Fig. 3-21. The spacing A of Fig. 3-21 is such as to rotate the reflected impedance of the trap to match and cancel the double-tuned impedance below $f_c - 1.25$ Mc, while the spacing B controls the cutoff sharpness. The over-all result is that of presenting to the tube a wide bandpass determined by a triple-tuned circuit. The circuit can be easily tuned or adjusted without special test equipment other than a RF sweep generator.

A constant-impedance sideband filter is simply what its name implies. It has a constant input impedance across the frequency range concerned and, as such, is not primarily a part of the tube output circuit. Figure 3-25 shows functionally one type of constant-impedance filter. Operationally, this type of filter is composed of a bandpass filter which has, shunting its input side, a band reject filter so tuned that the two filters complement each other, thus presenting to the transmitter a constant-impedance resistive load. This filter is usually more costly, and it normally requires more skilled personnel for its alignment. Constant-impedance filters can take other

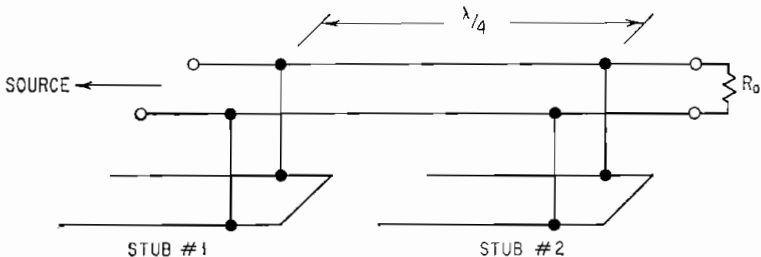

FIG. 3-26. Subcarrier trap.

forms, such as, for example, the use of two bandpass sections so phased that the filter presents a constant resistance to transmitter.

The subcarrier trap, $f_c - 3.58$ -Mc trap, used to remove the lower color-subcarrier sideband is sometimes made a part of the VSB filter and at other times is a separate

filter in the antenna transmission line. When the trap is in the transmission line, it can be similar to that shown in Fig. 3-26. Stubs 1 and 2 are such as to be series resonant at $f_c - 3.58$ Mc and are spaced electrically $\lambda/4$ apart at f_c to have their reflected reactive components cancel at the actual carrier frequency.

The upper-sideband filter is generally a video-frequency low-pass filter with 20-db attenuation starting at 4.75 Mc.

The harmonic filter is of the transmission-line variety which can take the form of either a bandpass filter or a low-pass filter. Whenever it is desired to feed a single antenna with both aural and visual transmitters, some form of diplexer is necessary. A bridge diplexer is used to feed batwing antennas, while a "slot" diplexer can be used to feed an antenna such as a helical, which requires a single-line feed only.

AURAL TRANSMITTER—BASIC CIRCUITRY

Since the aural transmitter is basically a FM transmitter and is covered in another chapter, this portion will be touched upon very lightly.

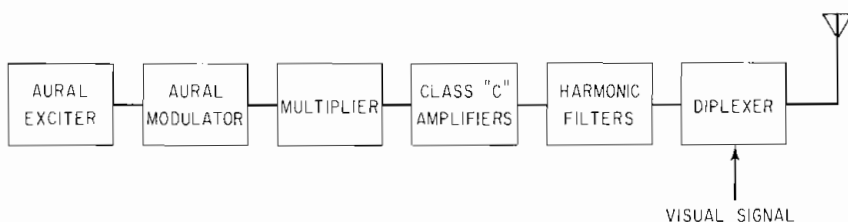

FIG. 3-27. Block diagram—aural transmitter.

Figure 3-27 is a block diagram of the aural transmitter, basically separate from the visual, and shows its functional parts.

Aural Exciter

The aural exciter generates and determines the frequency, which, after suitable frequency multiplication, serves as the aural carrier or center frequency.

Those equipments employing phase modulation to achieve the FM signal use a separate crystal oscillator to derive the basic frequency signal. With a crystal-controlled oscillator it is possible to achieve the degree of accuracy needed to place the final aural carrier or center frequency 4.5 Mc above the visual carrier frequency.

In general, when using a phase-shift type of modulator, the frequency at which the oscillator operates is selected on the basis of many considerations. The selection of the frequency is a compromise based on the optimum frequency for phase-shift modulation, considering the low-frequency distortion allowable and the amount of frequency multiplication necessary to achieve the required frequency deviation. The optimum crystal-oscillator frequency is between 100 and 200 kc for Channels 2 through 83, with the low VHF channels using a nominal 100-kc frequency and the other channels using a nominal 200 kc.

For those aural transmitters that use a reactance-tube modulator, the basic oscillator is not crystal controlled, since the oscillator frequency must be made to vary in accordance with the audio modulation to produce the desired FM signal. Since the center frequency is not directly crystal controlled, some means must be provided to maintain the center frequency at the desired or assigned frequency. This center-frequency control is generally accomplished by sampling the output signal, frequency-dividing it down, and then comparing the resulting signal with a known crystal. The error in frequency or phase is then fed back as a correction signal to the oscillator.

Aural Modulator

Two types of frequency modulation are commonly used in aural television transmitters: one is direct frequency modulation using a reactance tube modulator, and the other is phase-shift modulation which is converted to frequency modulation by means of filters and limiters.

In the reactance-tube modulator, direct frequency modulation takes place by having the reactance of the oscillator vary at an audio rate to cause the oscillator frequency to deviate the required amount to achieve a maximum frequency deviation when the audio signal is a maximum. Figure 3-28 shows a simplified reactance-tube modulator.

In the reactance-tube modulator the basic oscillator is a free-running oscillator whose center frequency of oscillation is determined by the total tuned-plate impedance of the oscillator. If the frequency of oscillation is to vary, it will be necessary somehow to change the reactance of the oscillator output circuit. In order to pro-

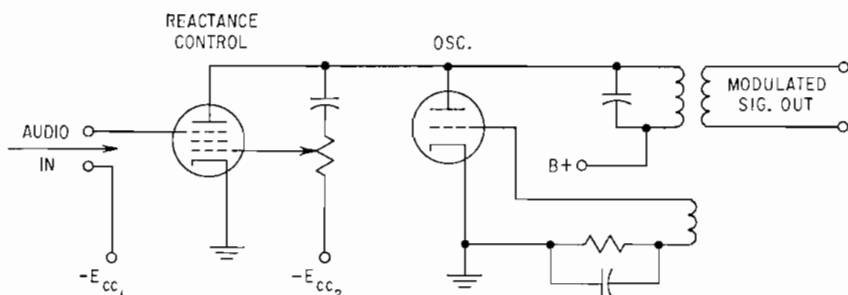

FIG. 3-28. Simplified reactance-tube modulator.

duce an apparent change in the reactance of the oscillator circuit, a sample of the output can be taken through a RC network to derive a current 90° out of phase with the tank voltage. This 90° current can then supply a grid voltage to the reactance tube in such a manner as to cause the reactance tube to supply a 90° current component to the oscillator tank. If the 90° reactance-tube current is then varied at an audio rate, the result is an oscillator output which varies in frequency at an audio rate.

While this is a relatively simple method of obtaining FM modulation, the problem of maintaining the center frequency within the required limits is complicated by the fact that the oscillator is not directly crystal controlled. To achieve the required center-frequency stability it is, therefore, necessary to sample the modulated output frequency and to divide down to some low frequency for comparison purposes with a crystal-controlled reference oscillator. Both the divided frequency and the crystal reference frequency are beat together, with their difference frequency or phase error used as a control signal to be fed back to the main oscillator as a correction factor.

The other commonly used method of obtaining FM is to employ a phase modulator which, by the use of a proper filter in the audio and limiting of the RF, will result in the desired FM output signal. Of the two familiar types of phase modulators, the type that makes use of the varying-amplitude trapezoid is most often used in television transmitters.

A crystal-controlled oscillator supplies the center frequency for the clipped sawtooth-phase modulator. The crystal frequency is used to drive a sawtooth generator which is clipped into a trapezoid at different levels, depending upon the level of the audio signal. Once the clipped trapezoids have been derived, the signal is sent through a differentiating circuit, which results in a position-modulated signal varying at an audio rate. Once the position-modulated signal is derived, a simple series of

frequency multipliers and limiters are used until the desired final frequency is achieved with the proper frequency deviation.

Figure 3-29 shows an ideal sawtooth which is to be clipped. Referring to Figs. 3-29 and 3-30, it is seen that the maximum phase shift possible is 2π radians or 360° . Practically, something less than 2π radians can be achieved because the sawtooth does

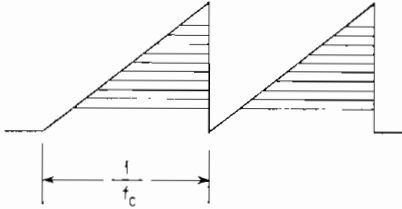

FIG. 3-29. Clipped trapezoid.

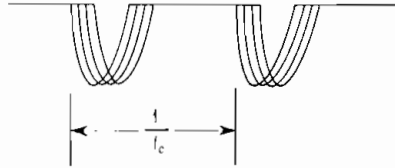

FIG. 3-30. Position modulator.

require a definite rise time. From the knowledge of the maximum phase shift obtainable or to be used, the following relations determine the frequency multiplication and the crystal frequency at which the phase modulation occurs.

$$\Delta f_1 = m f_m$$

where m = radians swing at the crystal frequency

f_m = audio-modulating frequency

Δf_1 = maximum frequency swing from center or crystal frequency

$$M = \frac{\Delta f_2}{\Delta f_1}$$

where M = multiplication factor to achieve required swing at final carrier or center frequency

Δf_2 = maximum frequency swing around carrier or center frequency

$$f_{cr} = \frac{f_{ca}}{M}$$

where f_{ca} = aural center frequency

f_{cr} = crystal frequency

In order to process the signal from phase modulation to frequency modulation, it is necessary for the audio amplitude-vs.-frequency response to have a drooping response, so that f_1 is a constant with change in audio frequency. This attenuation rate must be $m = k/f_m$, so that $\Delta f = m f_m = k f_m / f_m = k$.

The FCC specifies that pre- and deemphasis be used in aural transmitters and receivers, respectively, in order to obtain a more favorable noise situation. The pre-emphasis of 75 μ sec uses a simple reactance-resistor circuit which is placed in the audio circuit.

Frequency Multipliers

Once the desired modulation has been achieved, it is necessary to use frequency multipliers to arrive at the final aural center frequency. This frequency multiplication can consist of straight multiplication or a combination of multiplication and heterodyning. If other than straight frequency multiplication is used, due consideration must be given to the proper Δf_1 at the crystal or modulation frequency.

RF Amplifiers

Since an ideal FM signal is a constant-amplitude signal with the intelligence located in the instantaneous frequency, it is possible to use the most efficient type of power amplifier to achieve the desired RF power output to the antenna—Class C amplifiers.

The design of Class C amplifiers is reasonably well known; therefore, this subject will be touched upon very briefly.

Since the object of using Class C amplifiers is to achieve maximum power output together with maximum plate efficiency, the preliminary work should be done on a set of the manufacturer's tube curves, preferably the constant-current curves. Using the constant-current curves, it is possible to determine the tube and circuit performance by the use of graphical integration. Once the d-c and fundamental voltages are found, the following relations hold:

$$\text{Power input } (P_{in}) = E_{bb}I_b$$

where E_{bb} = supply voltage

I_b = direct plate current

$$\text{Power output } (P_o) = \frac{E_0 I_{pl}}{2}$$

where I_{pl} = RF fundamental current (peak)

$$R_L = \frac{E_0}{I_{pl}}$$

where R_L = impedance presented to tube

E_0 = fundamental frequency-voltage component (peak)

$$\text{eff} = \frac{P_o}{P_{in}}$$

The tuning of the Class C amplifiers is simple and is done with the normal circuit meters.

1. Tune the plate circuit for a minimum d-c plate meter reading. This minimum meter reading indicates a maximum R_L for the most practical case where the tank circuit Q is reasonably high.

2. The grid circuit d-c ammeter will indicate a maximum if the grid circuit is properly tuned and coupled, provided, of course, that the tube normally draws grid current. (This presupposes that the stage is sufficiently neutralized.)

The FCC specifies that the output power shall be determined by the indirect method, using the efficiency factor determined by the equipment manufacturer.

$$P_o = E_{bb}I_b F$$

where E_{bb} = plate supply voltage

I_b = direct plate current

F = efficiency factor

The direct method of measuring power can be used for checking the power output and the efficiency factor. The direct method uses some type of dummy load for the antenna with a calibrated meter indicating watts output to the load. Since an antenna and a dummy load may present slightly different load impedances, it is necessary to have equal I_b meter readings for both cases. Equal I_b readings generally require a slight final plate circuit adjustment when moving from the dummy load to the antenna.

RECTIFIER AND REGULATED POWER SUPPLIES

Along with the consideration given to the proper audio, video, and RF circuits, equal care must be taken with the all-important power supplies.

In the visual and aural circuits the choice must be made as to whether or not to use regulated power supplies and whether to use multiphase or single-phase sources. All such decisions, of course, must be made on the basis of an individual design, considering the power rating of the equipment, the hum requirements, the regulation necessary, and so forth.

For television transmitters the economical crossover point for the choice between single-phase and three-phase a-c supplies seems to be the 1-kw output rating.

In general, regulated power supplies are used for visual modulators and screen supplies of the visual RF stages. Unregulated but highly filtered supplies furnish the additional voltages required by visual exciters, aural exciters, aural modulators, and the high voltages for the plate circuits of the RF stages.

In selecting a rectifier circuit, the choice of whether to use rectifier tubes or semiconductors is one which must be made on the basis of economy and performance. For low-voltage circuits it is economical to use germanium or silicon semiconductors, while in high-voltage rectifiers the low peak inverse rating of semiconductors may make it more economical to use mercury or high-vacuum tubes. Likewise, on the basis of performance there is room for making a choice: gas kicks and flash arcs occur in tube rectifiers, while problems can also occur in series semiconductors if they are improperly applied.

If tube rectifiers are used, some form of current protection should be employed to limit any instantaneous overload in current due to arc backs and short circuits. In addition, quarter-phasing of the filaments sometimes improves the current rating of the rectifier tubes in polyphase rectifiers. Reference to Fig. 3-31a and b will aid in the explanation for the quarter-phasing of voltages in rectifier tubes. When a rectifier tube conducts, the voltage drop across it is relatively small, so that the filament voltage is a significant value in comparison. If both the plate voltage and the filament voltage are in phase, one side of the filament cathode tends to draw most of the current, causing excessive localized heating of one side of the cathode heater. If the filament cathode presented a uniform or constant voltage for the instant of maximum i_b , then the current to the cathode would be received in a uniform manner across the cathode surface. Quarter phasing, or causing the filament voltage to be 90° out of phase from the supply voltage e_b , will allow the filament voltage to be at zero potential when the i_b current is a maximum.

The procedure for designing filters to remove the various ripple voltages is presented adequately in numerous textbooks. It is enough to say that generally for unregulated power supplies a filter is required which will result in a hum level attenuation of 65 to 70 db for the ripple frequency out of the power supply. It is obvious

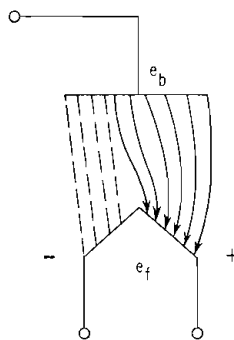

(A) CURRENT DISTRIBUTION -- NOT QUARTERPHASED

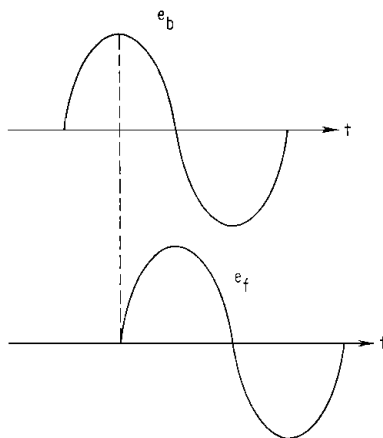

(B) VOLTAGE QUARTERPHASED

FIG. 3-31. Quarter-phasing rectifiers.

that a single-phase a-c source will require more filtering than a three-phase source because the fundamental ripple frequency is lower and the percentage of ripple is higher. In addition, it is important that the input inductance of the first filter section (when LC filters are used) should be such that current flow is always maintained. In other words, the minimum inductance should be

$$L = \frac{E_1 R_{\text{eff}}}{E_0 \omega}$$

where E_1/E_0 = ratio lowest frequency ripple component to d-c voltage output

$$\omega = 2\pi \times \text{lowest ripple frequency}$$

$$R_{\text{eff}} = E_{\text{dc}}/I_{\text{dc}} \text{ (lowest)}$$

It is important to consider the effective source impedance of the rectifier-filter combination. The regulation of the supply should be good enough to allow meeting the signal-regulation requirement from a black to a white picture.

Again, regulated power-supply design is adequately covered in numerous texts and will not be covered here except to say that the filtering required is generally in the order of 45 to 50 db, since the process of regulating the voltage from the filter does add a significant degree of effective filtering. Also, it is important that where twin triodes are used as the passing tube in series regulators, a small cathode resistor should be used in each section to balance the current. A small resistor in each plate also tends to reduce the possibility of oscillations.

Concerning fixed bias supplies, the choice of whether to use regulated supplies or not is generally a choice based on economy. The most practical choice, generally, is to use an unregulated filter supply with a high ratio of shunt bleeder current to grid current. A bias supply of this nature will commonly have a 5-to-1 ratio of bleeder current to grid current.

It is important to bear in mind that in all power-supply circuits associated with video and RF circuits the video impedances must be minimized. If, for instance, the visual wideband RF stages see a video impedance back through any of the power leads, the RF circuit will not perform as expected and the picture will in some manner deteriorate.

CONTROL AND PROTECTIVE CIRCUITRY

In television transmitters as well as in other transmitters the control and protective circuitry is of extreme importance. This circuitry has many configurations, depending upon the design and the designer, and consequently, only a general discussion can be presented here.

For control work, it is important to bear in mind what is to be controlled, what the sequence of control is to be, and the degree of control desired. In general, the items to be controlled are the cooling medium, the filaments, the low-voltage power supplies, the bias voltages, and the high-voltage supplies. In addition, it is common practice to allow for separate application of the voltage supplying the aural and visual transmitters if common power supplies are used. To the extent possible, the control circuitry should be such that minimum operator effort is required.

The following sequence of control is usually employed:

1. The transmitter START button or switch is operated in such a way that the air blower or the water pump operates first.
2. The filament supply is then automatically activated.
3. When the filament supply is activated, a time-delay circuit associated with the filaments automatically places at least a 30-sec time delay in the way of subsequent circuit activation. The delay is for the filament warm-up time necessary for some of the higher power tubes. Were the delay not incorporated, the tubes could be damaged should plate voltage be applied before sufficient filament warm-up.
4. Once the filaments have sufficiently heated during the delay time of 30 sec, the low-voltage and bias supplies are activated. Once the low-voltage supplies are activated, the transmitter is in a position to operate with one additional operation.

5. For complete operation of the transmitter, the final operation of the high voltage is, or should be, an operator function.

Thus, it is seen that the operation of the transmitter can be accomplished with two manual operations, the first operation automatically handling the sequence of blower, filament voltage, and low-voltage activation, the high-voltage activation for output power being the second operation.

Incorporated throughout the control circuit should be pertinent protective circuitry to protect both the equipment and the operating personnel. Interlocks on access doors should interrupt all power, except to coolants and filaments, when access

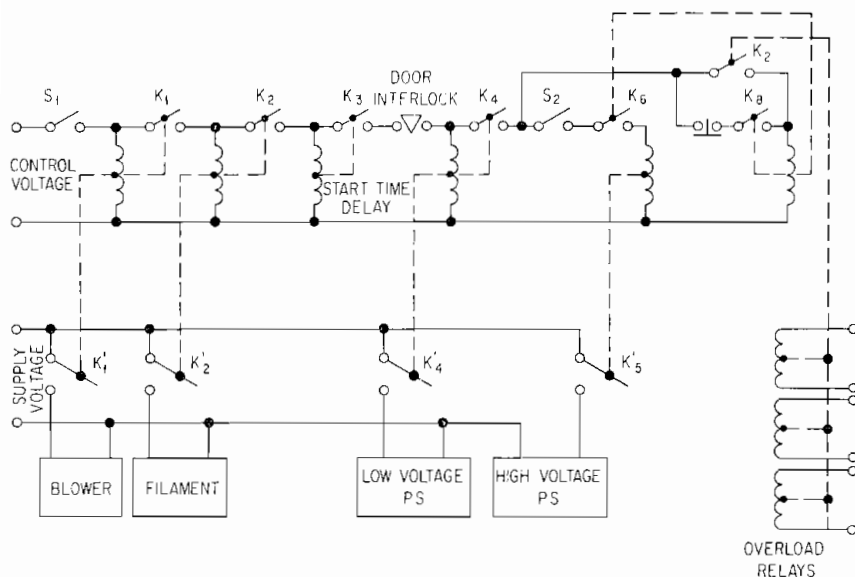

FIG. 3-32. A simplified control circuit.

doors are opened. Overload relays should protect all power tubes by removing pertinent supply voltages to screens and plates.

Because relays are commonly used for automatic sequencing and circuit protection, much reliability must be placed directly on the relays themselves. Any failure of the relays, of course, means service interruption.

Figure 3-32 shows a much simplified control circuit which could be used in either or both of the aural and visual transmitters. Since this control circuit is in its simplest form, the sequence of operation is easily followed.

Starting Sequence

1. When S_1 is activated, the blower starts operating. (The blower should have an air interlock to prevent filament activation should the air fail or the blower run in reverse.)

2. After the blower operates, the filament relay is activated, closing the filament voltage contacts.

3. As the filament contactors are activated, a time-delay relay of 30 sec commences operation.

4. Once the 30-sec delay period ends and the door interlocks are closed, the low-voltage relays are activated, thus closing the contactors supplying the low-voltage power supplies.

5. With all the foregoing operations automatically completed, the operation of applying high voltage is under the control of the operator through operation of S_2 .

The control circuit in Fig. 3-32 shows overload protective relays which could be placed in the cathodes of any given tube. As shown, whenever an overload relay is activated, C_7 closes, in turn activating a relay to open C_6 and to close C_8 , thus maintaining the plate voltage in the OFF position and preventing the plate voltage from chattering off and on. Pushing the reset button will place the high voltage on again.

Stopping Sequence

Still referring to Fig. 3-32, the stopping sequence is a two step operation:

1. Open S_2 , thus removing the high voltage.
2. Open S_1 , thus deenergizing all the control relays. The relay that controls the blower should have an opening time delay in the order of 3 min to allow tubes time to cool off.

The control circuit shown is, of course, extremely simplified, but should more sophistication be desired, it could easily be incorporated with a rapid increase in the number of relays required.

A TYPICAL TRANSMITTER—TYPE TT-36-A HIGH-CHANNEL 50-KW TELEVISION SYSTEM

The General Electric Type TT-36-A high-channel 50-kw system shown in Fig. 3-33 consists of the following auxiliary equipment: a type TT-32-B 10-kw driver, a type TF-5-A 50-kw amplifier, a constant-impedance vestigial-sideband filter, two harmonic filters, and a diplexer if the system requires a separate diplexer. Some installations can call for a slot diplexer, which can then be a part of the VSB filter.

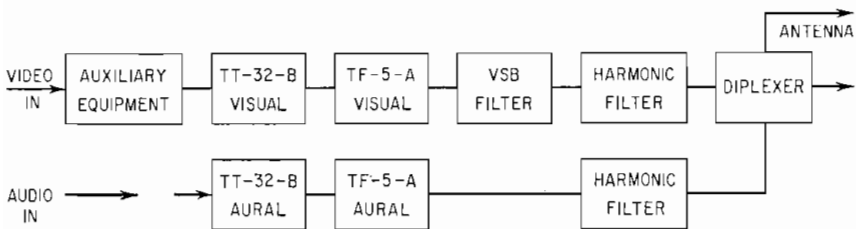

Fig. 3-33. Simplified diagram, type TT-36-A transmitter system.

Referring to Fig. 3-33, it can be seen that the video signal passes through some auxiliary equipment before reaching the transmitter. This auxiliary equipment consists of a video low-pass filter for attenuating 4.75 Mc and above, a variable low-frequency envelope-delay corrective filter, a receiver corrective filter, and a variable high-frequency envelope-delay filter. The variable filters compensate for the VSB filter and the upper-sideband phase error due to the bandpass restrictions of transmitters. All filters are isolated from one another by isolation amplifiers of 75 ohms forward and backward to minimize reflections.

The video then passes to the visual modulator. The video passes through two video amplifiers, a cathode follower, a linearity corrective stage, and an output stage to the modulated stage. The video stages are similar to those described in the theory. The modulator output stage is similar to the "stacked" amplifier described in the theory, using two 6146 tubes, thus making the modulator capable of driving into 180 μf with a video voltage in excess of 100 volts and with a frequency response flat beyond 7.5 Mc. Two keyed clamps are used to establish the d-c levels, one at the linearity corrective stage and one at the last amplifier to establish the d-c insertion or blanking level at the modulated-stage grid. The keying or clamping pulses are formed as outlined in the theory, using a shorted delay line and clipper tubes.

The carrier signal is generated in the visual exciter, which uses a crystal frequency in the range of 5 Mc, and after a multiplication of 24 the exciter delivers the carrier-frequency signal to the first of two C-W amplifier stages. The two amplifiers operate as Class C amplifiers to deliver the required power to the grid of the modulated stage.

The modulated stage can be described as a medium-level power-modulated stage. The modulation is the grid modulation discussed in the theory, with the modulated stage operating between Class B and Class C. The output of the modulated stage is wideband to accommodate the sidebands of the now modulated carrier.

Following the modulated stage are two Class B linear wideband amplifiers operating in a grounded-grid fashion. The circuitry is of the cavity type owing to the frequency range involved but is basically slightly overcoupled double-tuned circuits of the nature described in the theory. The final amplifier delivers 10 kw when the driver operates alone, but when driving the 50-kw amplifier, its output is reduced to the 5 kw needed to drive this amplifier to its rated output.

Following the type TT-32-B driver is a wideband Class B linear amplifier, type TF-5-A, using two 6L6251 tetrodes in parallel, which delivers a 50-kw output. This stage operates as a grounded-grid stage with an input-matching circuit to transform the circuit input impedance to the impedance into which the driver is designed to work. While the amplifier circuit is cavity-type circuitry, the output again assumes the slightly overcoupled double-tuned circuit described in the theory.

Immediately after the amplifier is a harmonic filter and a vestigial-sideband filter in that order. The VSB filter is of the constant-impedance type which lends itself readily to switching various driver and amplifier combinations. After the harmonic filter and the VSB filter, the RF signal passes to the diplexer.

The aural transmitter begins at the aural exciter of the driver, which has a separate oscillator of the Colpitts variety operating at a nominal 200 kc. Since frequency modulation is arrived at through the type of phase modulation described in the theory, it is possible to crystal-control the center frequency accurately without referencing to the visual exciter. Following the oscillator is a sawtooth generator, which the audio signal modulates by clipping. Following the sawtooth clipping operation by the audio there is a differentiating circuit which derives the 200-kc pulses that now appear as a pulse-position-modulated signal. The resulting signal is limited, filtered, and multiplied 972 times to arrive at the desired final aural carrier center frequency. The audio signal is processed both for the preemphasis required by the FCC and for the linear deemphasis dictated by the phase-modulation process prior to modulation of the sawtooth.

The FM signal out of the modulator-exciter is amplified by three Class C stages which deliver a nominal 5 kw of aural power, although when the type TF-5-A aural amplifier is driven, a nominal 2.5 kw is required. The circuitry and the construction essentially duplicate the like stages in the visual driver.

The type TF-5-A aural amplifier delivers a 26.6-kw signal, again using the basic circuit of the visual amplifier with the circuit tuned to a narrower bandwidth. The circuit also operates as a Class C stage instead of Class B as in the visual.

The FM signal leaves the aural amplifier through a harmonic filter to the diplexer and finally out to the antenna along with the visual signal.

INSTALLATION CONSIDERATIONS

When installing a transmitter it is wise to make sure that sufficient space is available to situate the transmitter so that complete access to its various parts is possible. Space should be available for necessary supporting auxiliary equipment with room left for expanding the equipment complement, such as, for example, a standby transmitter.

It is important to have a good grounding system for the installation in order to reduce feedback of spurious signals into low-signal equipments, thus degrading the output signal.

In addition to a good ground, it is usually wise to keep the signal cables separated from the a-c power lines, since the transients from rectifiers can mix with the incoming

signals, again degrading the signal. It is wise to use separate wiring ducts for signal cables and a-c power lines. Where it is not possible to keep the lines separated, a good means of shielding must be used.

A disconnect device capable of interrupting the power source on a short circuit should be connected between the transmitter and the power source. Various power sources can have different current capabilities which may need to be interrupted. If the disconnect device is not capable of interrupting the source short-circuit current capability, equipment damage can result. This disconnect device should be coordinated with the protective circuits of the transmitter so that it operates only in the event of operating failure of the protective circuit of the transmitter.

Before operation of the transmitter it is important to check the protective circuitry to prevent damage to equipment and/or personnel should there be short circuits, open circuits, and so forth. The various manufacturers' instructions on starting a given transmitter should be followed, since the procedure has been set up with equipment protection taken into account.

TEST AND ALIGNMENT

Once a visual transmitter is installed for operation, there remains the procedure of tests and alignment to ensure optimum operation.

If a transmitter has more than one wideband RF stage, it is necessary to align each stage with an RF sweep generator or some equivalent method. The general procedure is to start with the highest level stage and to tune successively lower power stages until all stages are tuned.

Once the RF stages are tuned, the video-frequency stages can be tuned or adjusted. The video-frequency stages consist of both the visual modulator stages and any auxiliary equipments, such as low-pass filters, phase-correction filters, and isolation amplifiers. The object is to have all the video stages as a system present a uniform amplitude-vs.-frequency response to the modulated stage of the transmitter. Since the auxiliary filters associated with the transmitter can accumulate an amplitude-response error, it is common practice to compensate for the response errors with the

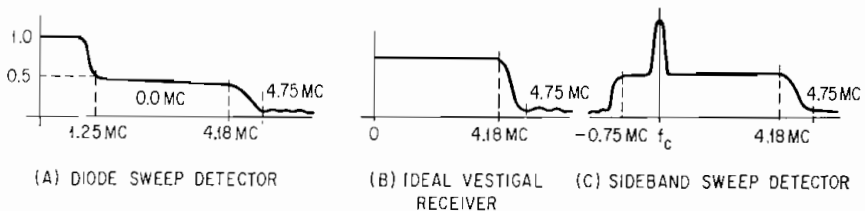

FIG. 3-34. Amplitude vs. frequency sweep detection.

peaking coils of the isolation amplifiers. The general approach is to have all auxiliary units flat, as a group, and the visual modulator flat, so that the two can be separated operationally should the need arise.

Once the video circuits and the RF circuits have been properly adjusted, an overall amplitude-vs.-frequency response check should be made to determine the transmitter system response. Figure 3-34 shows what the over-all response should look like, using the three possible methods of detection. For proof-of-performance tests a point-by-point amplitude-vs.-frequency response check is generally performed, using a field-strength meter. It is important that the proper operating conditions prevail when making the above test. If a composite test signal is used (with synchronizing pulses), there is no problem on setup, but if a noncomposite signal is used, the average power should be approximately one-fourth rated synchronizing peak power, since this ensures the measurement being made in the black-to-white picture region.

Once the desired amplitude-vs.-frequency response is achieved, the power-output

capability of the transmitter should be checked, because a bandwidth which is too wide could limit the power-output capability. The power can be checked with either black-picture modulation or with no modulation. The following equations hold for determining the synchronizing peak power when reading the average power on a calibrated wattmeter on a dummy load. The P_o reading should be that read on the dummy load for the peak power rating of the transmitter:

$$P_o = \frac{\text{peak-power rating}}{1.68} \quad (\text{for modulation with rated synchronizing pulses})$$

Pedestal level

$$P_o = \frac{\text{peak-power rating}}{1.78} \quad (\text{for no modulation})$$

Pedestal level

With the amplitude response and the power output properly adjusted, the linearity should be measured and adjusted if needed. The most commonly used procedure is to have a composite video signal with rated synchronizing pulses and a stair-step or sine-wave signal covering the black-to-white region, having 3.58-Mc sine waves superimposed. Care must be taken to have the transmitter operating at the desired operating power with the proper percentage of synchronizing height before attempting to measure the linearity. The linearity measurement must be made with a linear detector so that the depth of modulation can be controlled in order not to exceed $87.5 \pm 2\frac{1}{2}$ per cent. Figure 3-35 shows the system line-up for linearity testing.

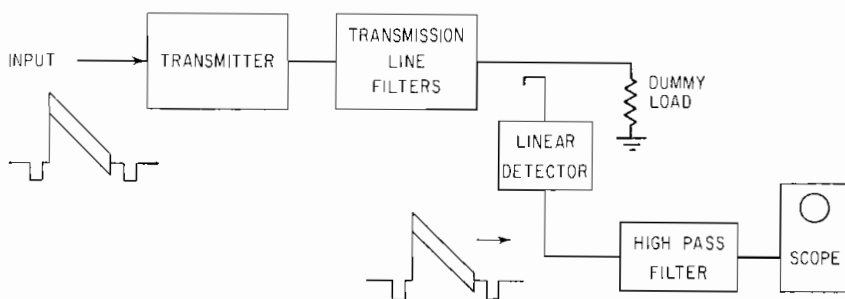

FIG. 3-35. Setup for linearity testing.

As seen in Fig. 3-35, the output from the linear detector will show the depth of modulation, and if the signal is then passed through a high-pass filter, the 3.58-Mc component can be displayed on an oscilloscope. While this display is viewed from a high-pass filter, the black-and-white stretch controls are adjusted so that the scope presentation shows a uniform amplitude (see Fig. 3-36).

Using suitable phase-measuring equipment, the above linearity-test setup can be used for measuring the differential phase shift between different brightness levels.

Measuring the envelope delay of the system is a difficult procedure because of the unavailability of commercial equipment to measure the entire frequency range under consideration. Therefore, it is common practice to use square-wave-type testing of the system to arrive at the desired transient response. The transmitter system, including delay-correction filters, is monitored with a vestigial-sideband demodulator similar to that shown in Fig. 3-37. The ideal demodulator should be envelope-delay-corrected in order not to introduce errors itself. With the envelope-delay predistortion required by the FCC out of the system, the transmitter delay-correction filters

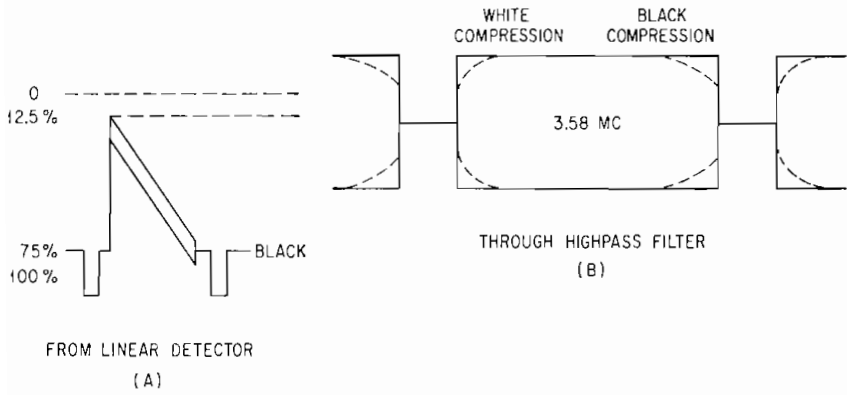

FIG. 3-36. Presentation for linearity test.

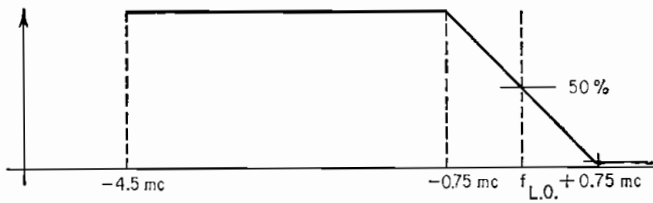

FIG. 3-37. Vestigial sideband detector IF response.

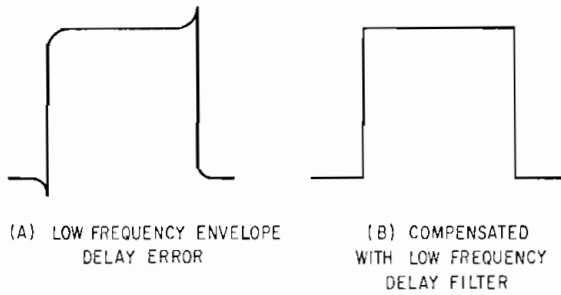

FIG. 3-38. Square-wave response—low frequency.

should be varied until the best transient response of 100-kc square wave is obtained (Figs. 3-38 and 3-39).

In addition to square-wave testing, some use is being made of $\sin^2 x$ testing, but this requires additional test equipment to furnish the test signal.

Once the transient response is optimized, the receiver predistortion is inserted into the system and the system is ready for visual operation. (The receiver predistortion

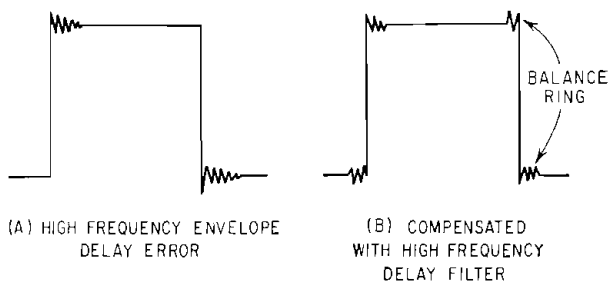

FIG. 3-39. High-frequency square-wave response.

will cause high-frequency ring to appear on the leading edges of the square wave. This ring will minimize in the home receiver.)

The aural tuning can be accomplished by peaking grid current and minimizing plate currents of the RF stages. Neutralizing can be checked and adjusted by having the plate-current minimum occurring as a grid maximum occurs while varying the plate tuning.

For a complete proof-of-performance test more complete testing is required both for setup and for obtaining numerical data.

MAINTENANCE CONSIDERATIONS

The maintenance procedure should be designed to offer the most satisfactory equipment performance, and it can be broken down into two classifications: equipment maintenance and signal-quality maintenance.

Equipment Maintenance

A periodic procedure should be set up to maintain the equipment operation at top form. The frequency at which the periodic maintenance is carried on depends to a great extent upon the local conditions, together with the desired reliability of operation.

In a dusty locale it is quite important to have frequent cleaning of dust from inside the cubicle, particularly from around high-voltage and high-frequency components. A vacuum cleaner is useful for gathering loose dust. When cleaning dust from around bypass "sandwiches," it is extremely important not to use a cleaning agent which would cause sheet mica to split or separate, since arcing can then result. Split mica sheets should be replaced as soon as possible.

Screws should be periodically tightened to prevent intermittent operation. Blower vibrations, particularly, can in time cause screws to loosen. Water-cooling systems should be inspected and cleaned periodically to reduce scaling, since scaling tends to restrict water flow in addition to reducing the heat transfer in heat exchangers.

Periodic inspection of contactors, switches, relays, and grounding devices should be made to assure continued equipment and personnel protection. Relays and contactors do become "pitted" and corroded with time and repeated operation, thus requiring maintenance at least on an annual or semiannual basis.

A set procedure for monitoring the operation of various tubes can aid tremendously in reducing off-air time. Once the approximate life and operating habits of a given

tube in a particular circuit are established, keeping a record of the operating hours of the tubes will indicate when a tube should be changed. On the subject of tubes, it is best to follow the manufacturer's suggestion upon first placing a tube in service, since proper installation procedure can help assure longer operation.

Signal-quality Maintenance

Maintaining signal quality assures that the picture and sound will consistently be satisfactory to the viewer while serving to keep the operating personnel informed on the system operation.

In addition to the proof-of-performance tests conducted each year, it is good practice to conduct special tests at rather frequent intervals to assure proper system operation.

In the visual transmitter, it has been found that the following tests help to maintain signal quality:

1. System amplitude-vs.-frequency response check
2. Linearity or differential gain adjustment
3. Transient-response test

The amplitude-vs.-frequency response check will assure the maintenance of the necessary bandpass to pass the signal frequency components properly. This test is easily made with a video sweep generator or a frequency burst generator. To a degree, this test is about the most important because the transient response is affected by the amplitude-vs.-frequency response, which is related to the phase- or envelope-delay response. It is desirable to have each portion of the video system flat within itself, with the over-all system flat within the limits set by the equipment manufacturer.

The linearity check and adjustment should be made when the amplitude-vs.-frequency test is made. This test can be made with any adequate stair-step or sawtooth test signal. In this test the first step is to establish a standard video signal level for the system. A 1-volt synchronizing peak to reference white at the transmitter is commonly used. With 1 volt of video going to the transmitter, the input gain of the transmitter should be set to give the rated depth of modulation, and the linearity should then be adjusted to the desired degree. A linearity of 90 per cent is generally considered adequate.

A transient-response test is made simply by observing the system performance using a square-wave signal, such as a window generator. This test will indicate tilt, smear, spiking, and ringing, and if photographs are used for comparing the system from time to time, it is possible to maintain the operation consistently.

PERSONNEL TRAINING

Too much personnel training cannot be done. All the operation and maintenance of a station is dependent upon the operators, and the quality of operation is directly related to their skill. Both equipment maintenance and picture quality are best assured by training each man.

Each operator should be very familiar with the equipment with which he is concerned. The individual instruction books should be read and studied. A planned system of rotating the operators on the maintenance of the various parts of the system will make sure that each person has the opportunity to learn by doing. In addition, planned trouble shooting on simulated problems can be conducted during off-air time to give practice in rapid repair.

In addition to equipment training, the operators can be trained to know what constitutes a quality signal. Often a trained person can observe the signal waveform and determine when maintenance is required. Signal quality can be improved if personnel are familiar with the FCC specifications and the EIA standard Electrical Performance Standards on Television Broadcast Transmitter, TR104. The EIA Standard includes methods of measurement which are standard for the industry.