

# SET DESIGN AND CONSTRUCTION

## Drama

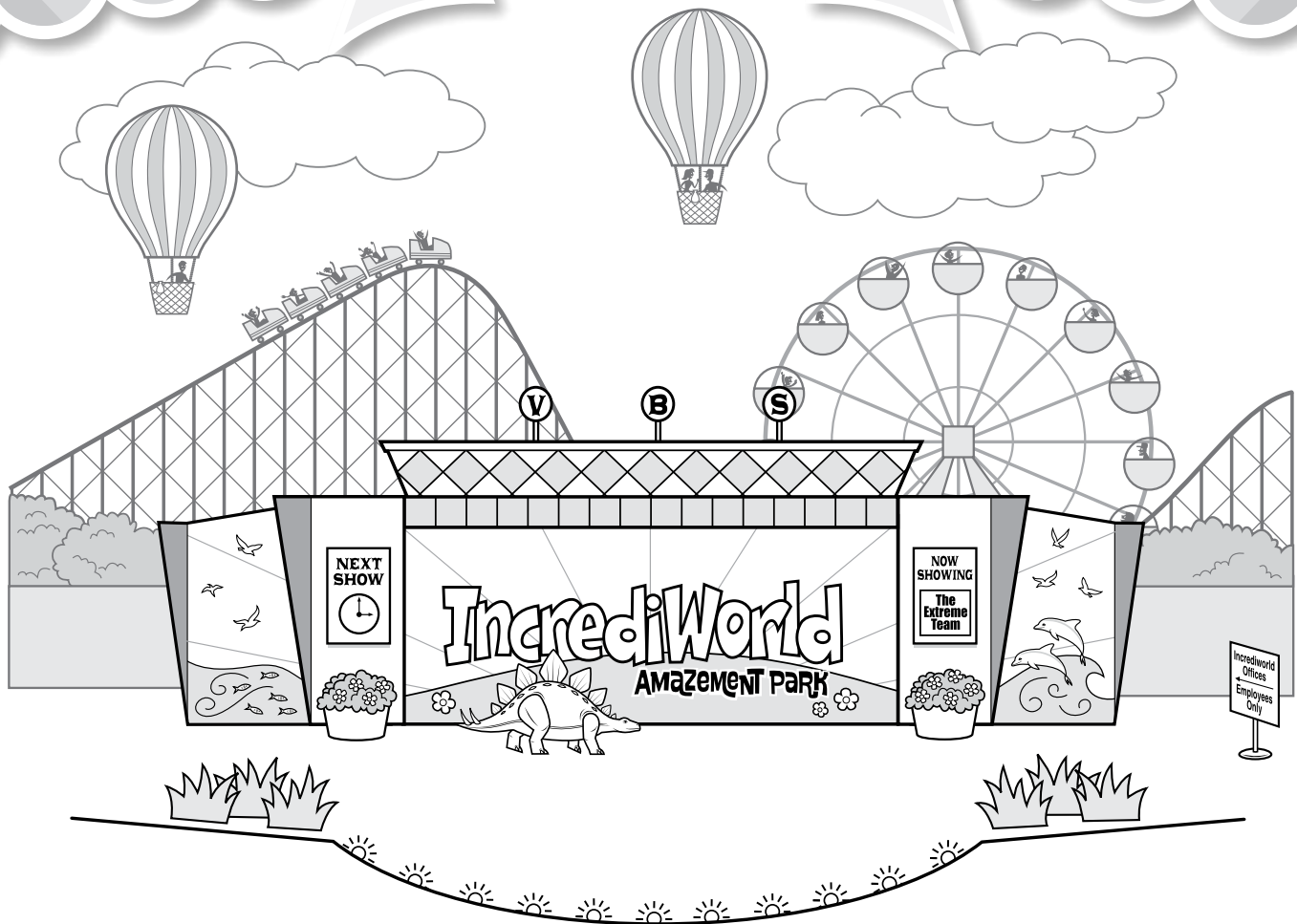

The set for your VBS is very important. It not only creates a setting for the drama, but also helps establish the mood for the entire VBS. A well-crafted set will excite the children's imagination, creating energy and enthusiasm.

The suggested design for your IncrediWorld set is shown above. Use it as a guide and, when necessary, adapt it to your particular setting and circumstance. It's designed to resemble an outdoor entertainment stage at a theme park with a view of the park in the background.

## STEP I: CONSTRUCT YOUR STAGE PANELS

For basic instructional videos on building stage flats and jack construction, please visit [YouTube.com/AnswersVBS](https://www.youtube.com/AnswersVBS).

The IncrediWorld Stage consists primarily of panels. There are four 4x8 center panels, six 3x8 entryway panels, two 4x8 sloping side panels, and two 2x8 horizontal crown panels. You may need to make size adjustments if your platform will not accommodate the set as shown. Your panels should be constructed using rigid materials, such as: corrugated cardboard, polystyrene insulation, luan plywood, or a combination of these materials. For best results, consider making “flats,” (panels attached to lightweight wooden frames) and “jacks” to prop them up.

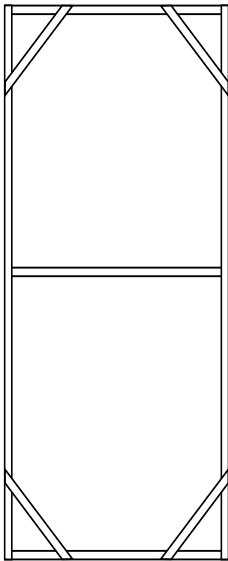
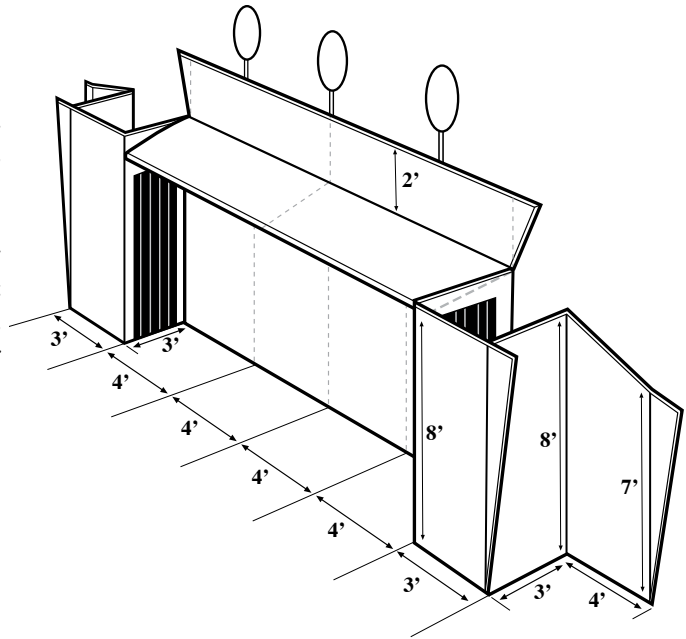

BASIC “FLAT” CONSTRUCTION

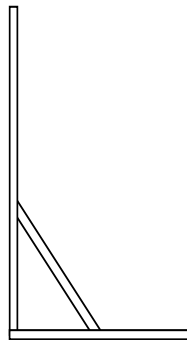

BASIC “JACK” CONSTRUCTION

### IncrediWorld Offices

For simplicity's sake, the set is designed with an imaginary “IncrediWorld Offices / Employees Only” area. It is located behind the stage and is identified with a directional sign. However, if your stage will accommodate a larger set, consider adding a small separate building for this purpose. It would need to be positioned to the right (stage left) of the IncrediWorld Stage, have a doorway, and be accessible to backstage. Or, if your auditorium already has a doorway in that area, simply decorate the doorway and add the appropriate signage, but be careful not to cover any exit signs.

### Entryways and Roof

The IncrediWorld Stage has two boxed entryways and a small roof. Each entryway is made with three 3x8 panels, including one with a flare and one with a doorway cut out of it. The roof is made of corrugated cardboard sheets and spans the area between the entryways. It is attached to the center panels in the rear and supported in the front by a lightweight wooden crosspiece that bridges the expanse.

### Stage Crown

Directly above the roof is a stage crown that rises above the rest of the stage panels. The crown is made with two horizontal 2x8 panels with flared ends. Above the crown are three evenly spaced circles that overlook the rest of the stage.

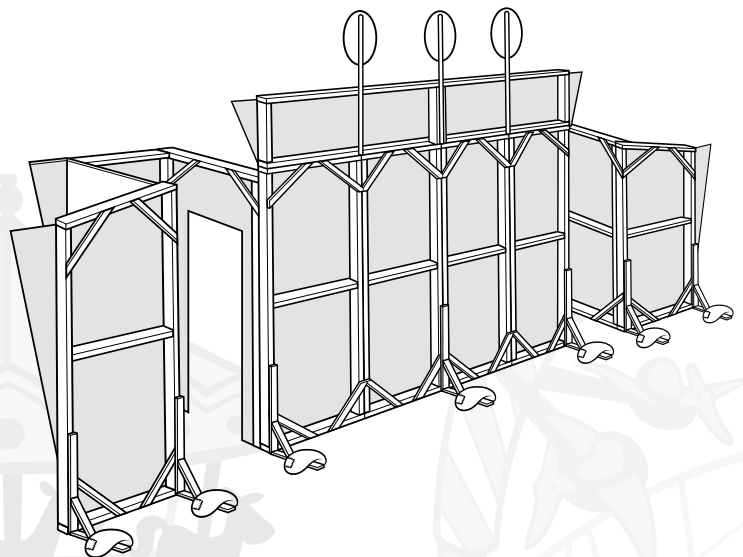

## STEP 2: PAINT YOUR STAGE PANELS

When it comes to selecting your paint colors, bright and bold colors are a must. Just think kids and theme parks. Bright blues and reds, oranges, golden yellows, lime greens, and hot pinks and purples are excellent choices. However, be careful with some colors, like bright yellow, that work well in small doses but can be too intense over larger areas. See the Assembly Resource CD-ROM for a few suggested color schemes.

For the land and water scenes, you'll have to freehand draw the hill with flowers, the sunburst, and the waves. Then, to add the various images (dolphins, fish, birds, and "IncrediWorld Amusement Park"), see the Assembly Resource CD-ROM. You'll need an overhead projector to enlarge and transfer them onto your stage panels.

### HOW TO ENLARGE AND TRANSFER CLIP ART

1. Photocopy the clip art onto transparencies.
2. Place roll paper or a rigid material against a wall.
3. Using an overhead projector to enlarge the clip art, shine the image onto the paper or rigid material, adjusting it as necessary for the size desired.
4. Trace the image outlines onto the paper or rigid material.
5. Paint the image and cut out.

## STEP 3: MAKE YOUR BACKDROP

A backdrop is an important part of the overall set. Not only does it help to cover the back wall of your platform, but it also helps to establish the theme park setting. So before you assemble your IncrediWorld Stage, add a backdrop of rides and attractions. We suggest that you start by draping the back wall with sky blue or black fabric. Black plastic can also work with any set. Then add some clouds (if using sky blue), a roller coaster, a ferris wheel, a couple hot air balloons,

and some foliage to create a theme park scene behind your IncrediWorld Stage. These items can be as small or as large as you like and can be made of cardboard or painted fabric. Again, be sure to use bright and bold colors in your decorations. See the Assembly Resource CD-ROM for clip art images of hot air balloons, roller coaster cars, and ferris wheel cabins.

## STEP 4: INSTALL YOUR INCREDI WORLD STAGE

After your backdrop is finished, begin to assemble your IncrediWorld Stage. First, set the center panels in place near the back of your platform, allowing for an adequate backstage area. Next, install both of the boxed entryways followed by

the stage roof. If necessary, drape the entryways with black fabric so that backstage is not visible to the audience. Finally, add the two side panels.

## STEP 5: ADD PROPS AND OTHER ENHANCEMENTS

Now, add props, stage lighting, plants, animals, birds, and other things to make your set come alive. The Assembly Resource CD-ROM has a printable sign for "The Extreme Team" and clip art images, including a *Stegosaurus*, large planters, "Next Show" and "Now Showing" signage, and tufts of grass. Use an overhead projector to enlarge and transfer

the images onto paper, poster board, or rigid materials such as corrugated cardboard or wood.

**NOTE:** If you are using corrugated cardboard, apply one coat of paint to the back of each piece, otherwise it will tend to curl with only one side painted.

Congratulations! You have successfully created your own IncrediWorld set!