





Prénom :

Date :











	qu - c - k - q	
	quatre	4
[k]	coq	
	koala	

LECTURE : phonologie 1



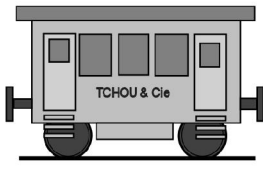
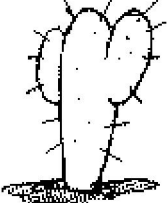

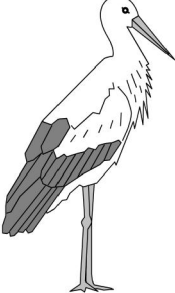
Je suis capable de repérer un son identique dans plusieurs mots.



Je colorie l'image quand j'entends [k].



LECTURE : phonologie 2



	qu - c - k - q
	quatre
[k]	coq
	koala
	4  

Je suis capable de localiser un son dans un mot.

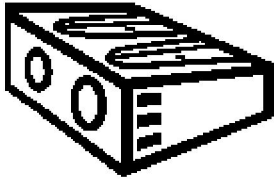

Je mets une croix où j'entends [k].

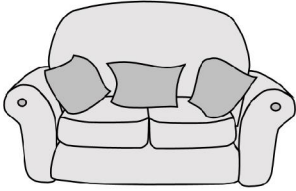
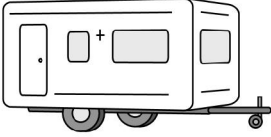

		
<input type="checkbox"/> <input type="checkbox"/> <input type="checkbox"/>	<input type="checkbox"/> <input type="checkbox"/> <input type="checkbox"/>	<input type="checkbox"/> <input type="checkbox"/> <input type="checkbox"/> <input type="checkbox"/>

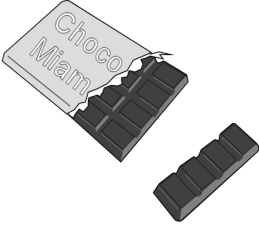
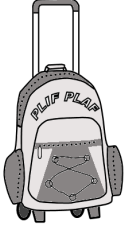
		
<input type="checkbox"/> <input type="checkbox"/> <input type="checkbox"/>	<input type="checkbox"/> <input type="checkbox"/> <input type="checkbox"/>	<input type="checkbox"/> <input type="checkbox"/> <input type="checkbox"/>

		
<input type="checkbox"/> <input type="checkbox"/> <input type="checkbox"/>	<input type="checkbox"/> <input type="checkbox"/> <input type="checkbox"/>	<input type="checkbox"/> <input type="checkbox"/> <input type="checkbox"/>

Prénom :

Date :

	qu - c - k - q
	quatre
[k]	coq
	koala
	4 

LECTURE :

discrimination visuelle

Je connais les lettres de l'alphabet.

Je connais les correspondances entre minuscules et majuscules d'imprimerie et majuscules et minuscules cursives.



J'entoure quand je vois la lettre k.

H	K	F	Y	K	R
k	l	h	k	t	b
h	l	b	h	h	h



J'entoure les mots où je vois la lettre k.





hache	kiwi	kangourou
KOALA	RECHAUD	SKIER
képi	biscotte	lacher



Je colorie les mots identiques de la même couleur.

coq	clés	cinq
COQ	coq	CINQ
clos	CLES	clés
CLOS	dos	cinq

LECTURE : combinatoire



	qu - c - k - q
	quatre
[k]	coq
	koala
	4 

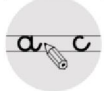

Je suis capable de repérer les syllabes d'un mot.

Je suis capable d'organiser des syllabes pour construire un mot.

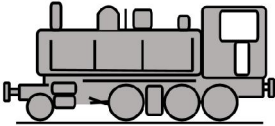

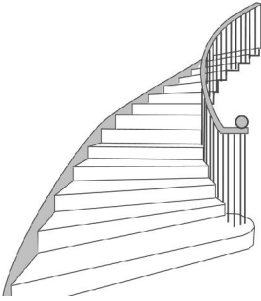
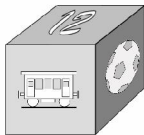

Je complète les mots avec : ca, ca, cu

		
lo__motive	é__le	é__reuil

		
es__lier	__be	__mion



Je reconstruis les mots avec les syllabes.

la	a	ko	ro	cau	rne
					
_____			_____		