

DÉTAIL A
Motirisation du tapis roulant

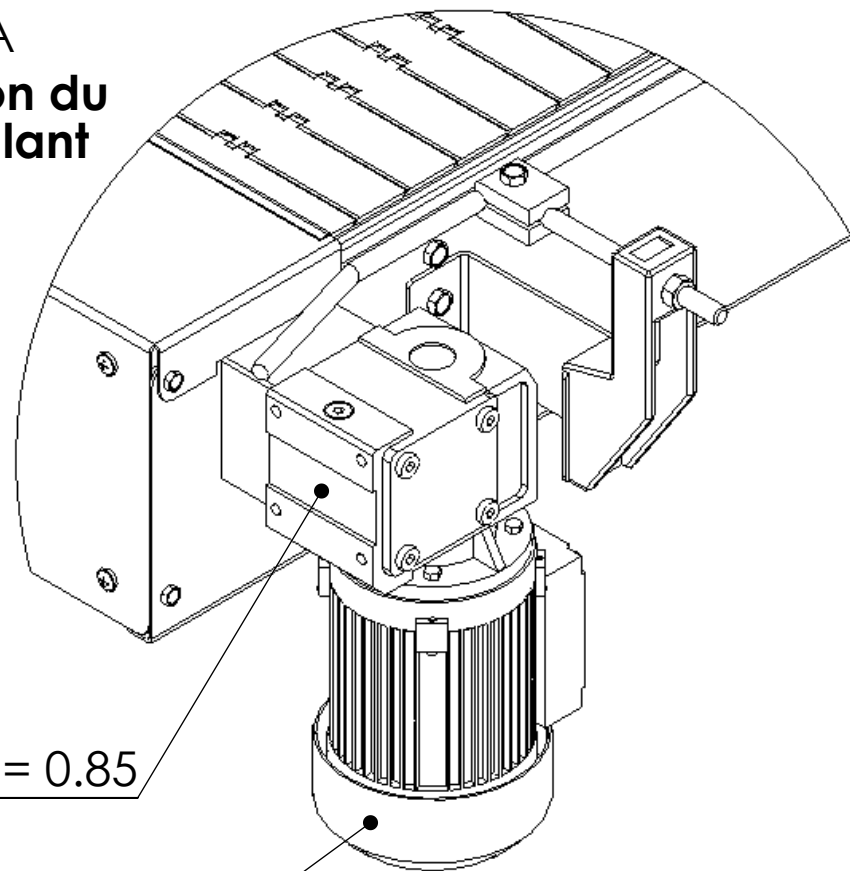

Réducteur
r = 1/20
rendement = 0.85

Moteur
N = 1430tr/min
P = 0.25KW

DÉTAIL B
Systeme de tension du tapis roulant

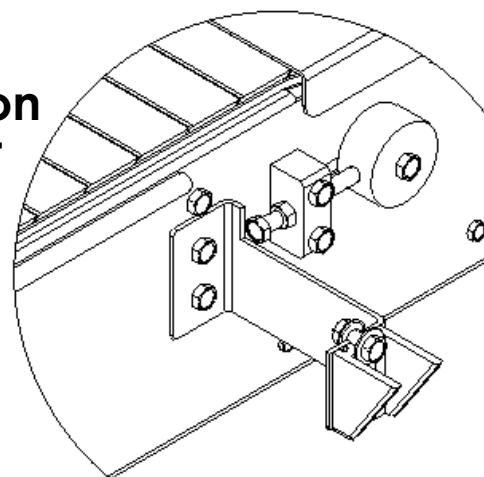

Caisse

Tapis roulant

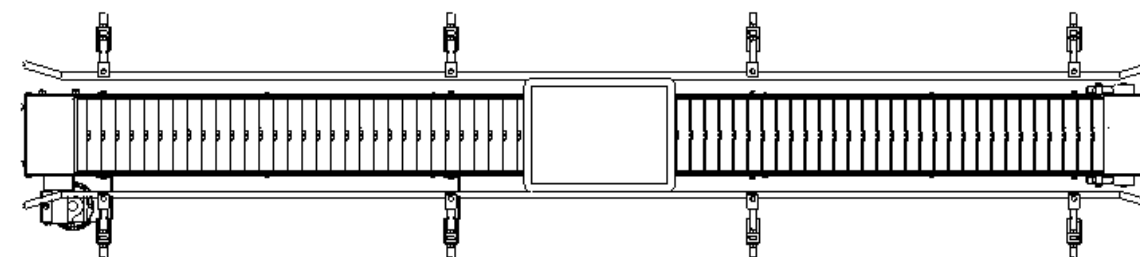
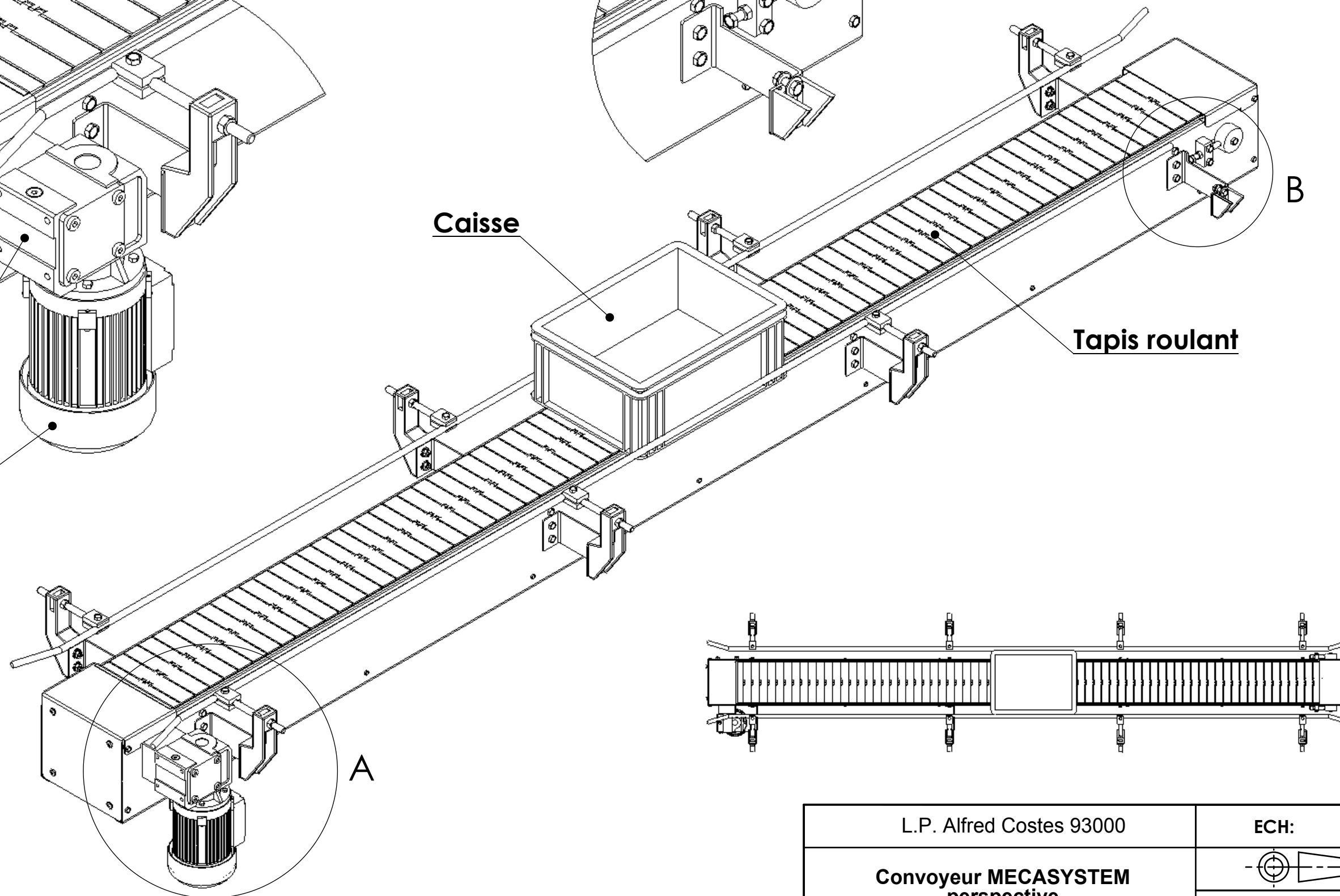

L.P. Alfred Costes 93000

Convoyeur MECASYSTEM
perspective

ECH:

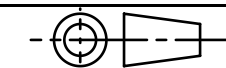

DT1