

**ENSEMBLE SUPERIEUR**

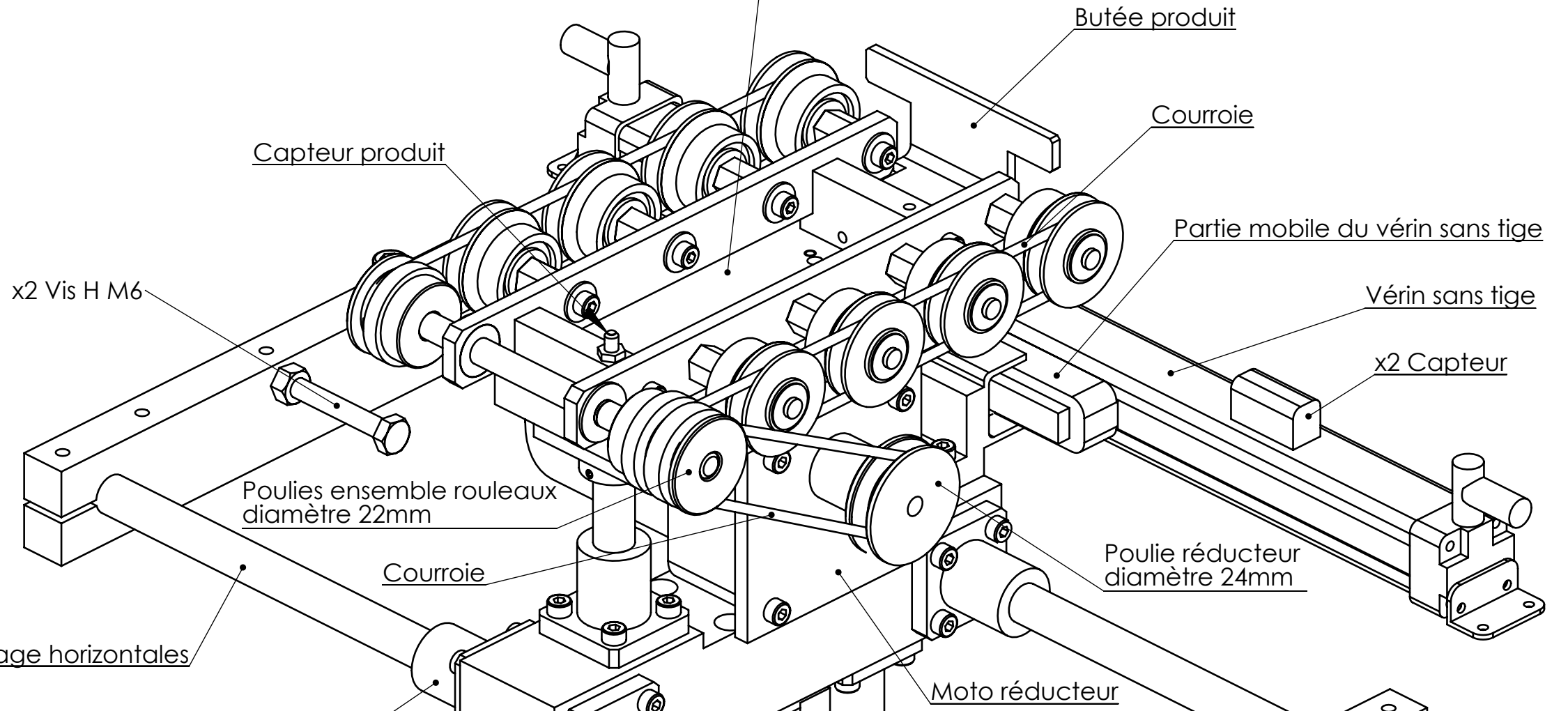

**POULIES DE L'ENSEMBLE SUPERIEUR**

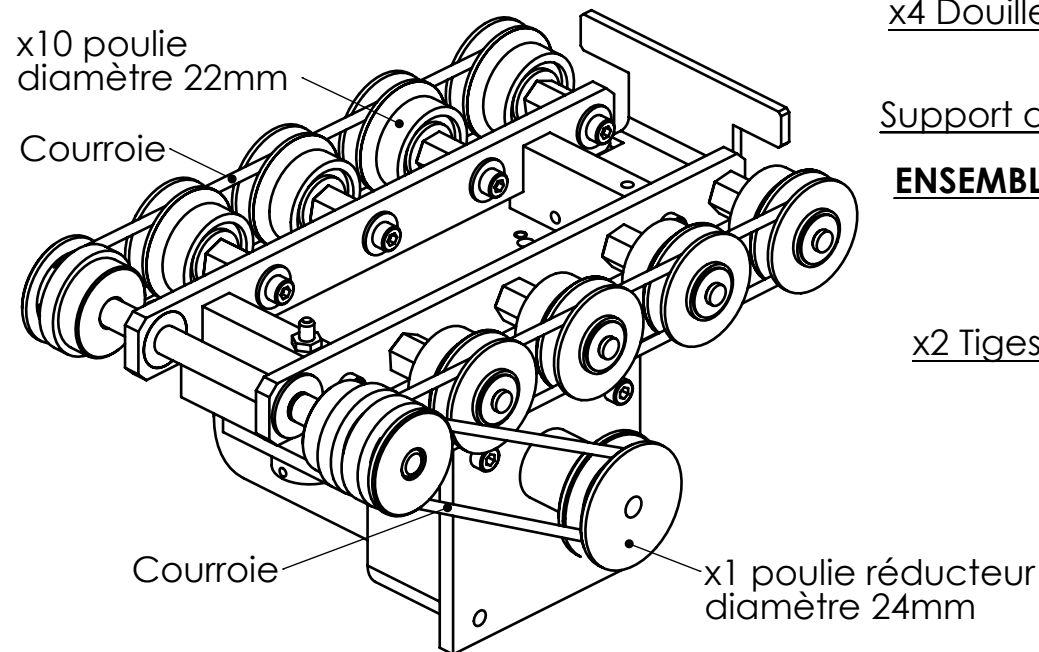

x4 Douille a billes

Support de douilles

**ENSEMBLE INTERMEDIAIRE**

x4 Douille a billes

x2 Tiges de guidage verticale

Moto réducteur

Structure

**ENSEMBLE FIXE**

Vérin

L.P. Alfred Costes 93000	Echelle
<b>Support mobile</b>	
	Annexe 2