

# Matériel 37 Jeu de Lucky Luke

## Reconnaitre des carrés plus vite que son ombre

Séance 1



Indique les figures qui sont des carrés.

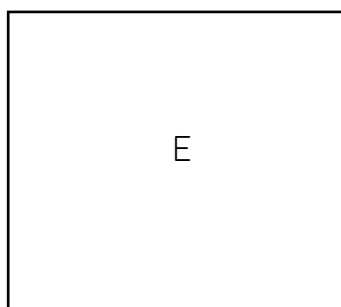
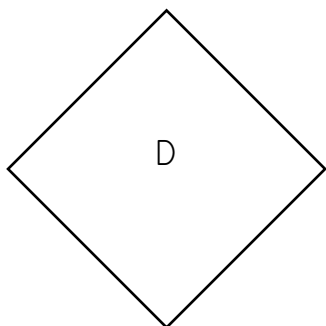
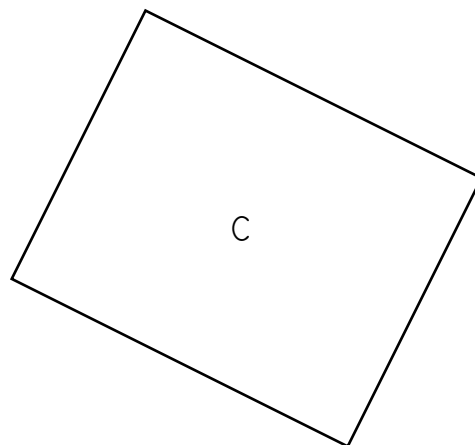
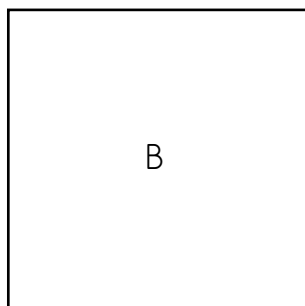
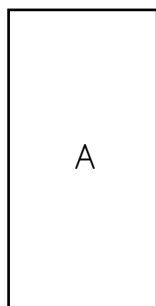

# Matériel 37 Jeu de Lucky Luke

## Reconnaitre des carrés plus vite que son ombre

Séance 1

Indique les figures qui sont des carrés.

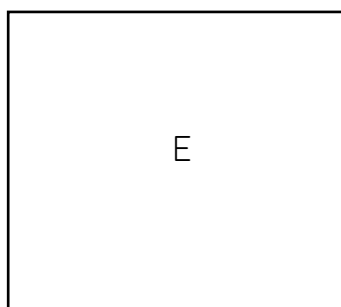
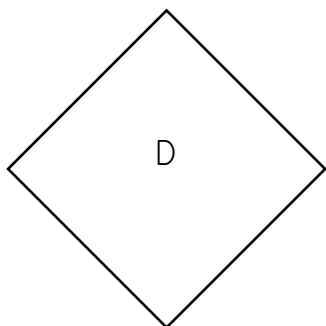
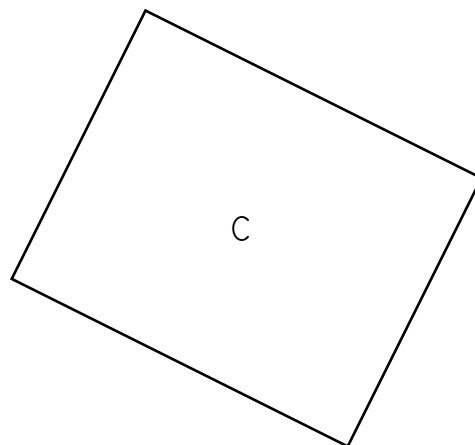
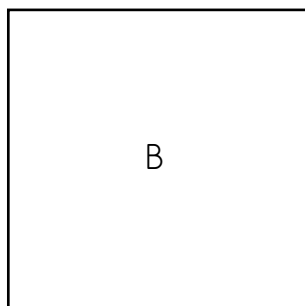
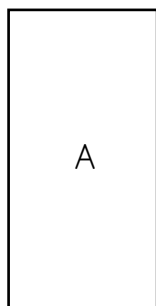

Matériel 37 **Jeu de Lucky Luke**  
**Reconnaitre des carrés plus vite que son ombre**

Séance 3



Indique les figures qui sont des carrés.

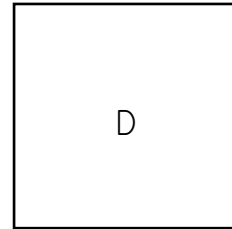
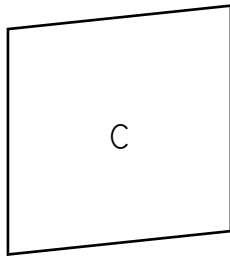
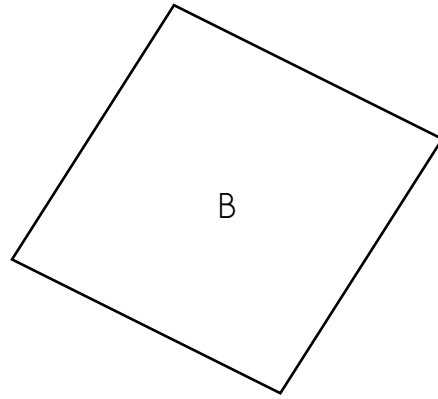
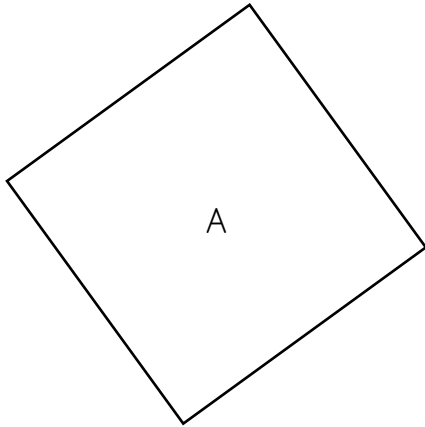

Matériel 37 **Jeu de Lucky Luke**  
**Reconnaitre des carrés plus vite que son ombre**

Séance 3

Indique les figures qui sont des carrés.

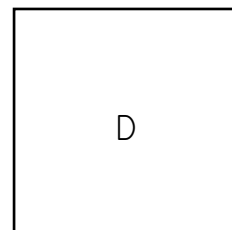
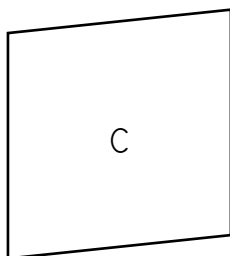
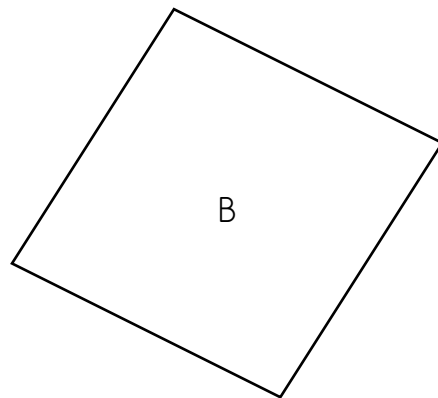
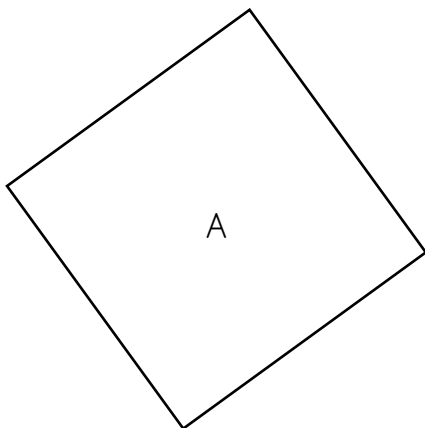



**Un carré** a ses  
**4 côtés de même longueur**  
ET  
**4 angles droits.**

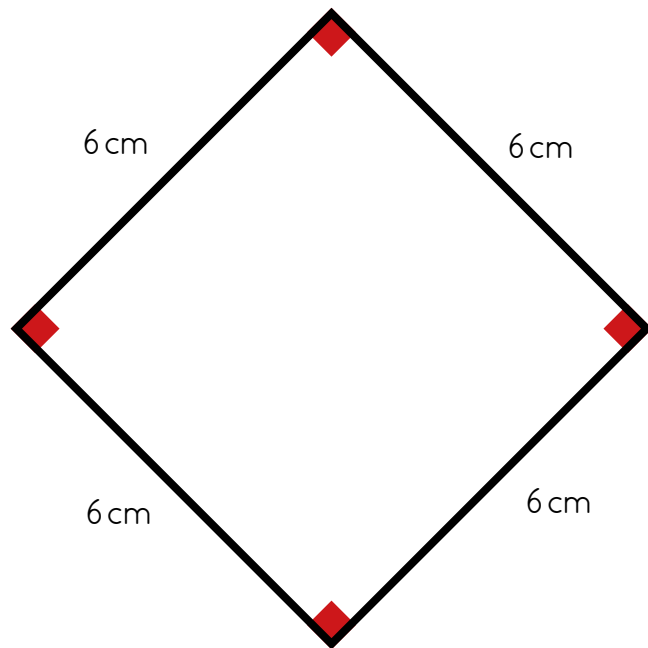
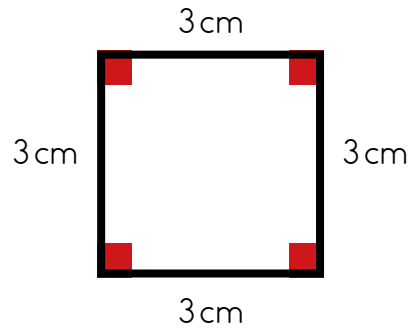

**Un carré** a ses  
**4 côtés de même longueur**  
ET  
**4 angles droits.**

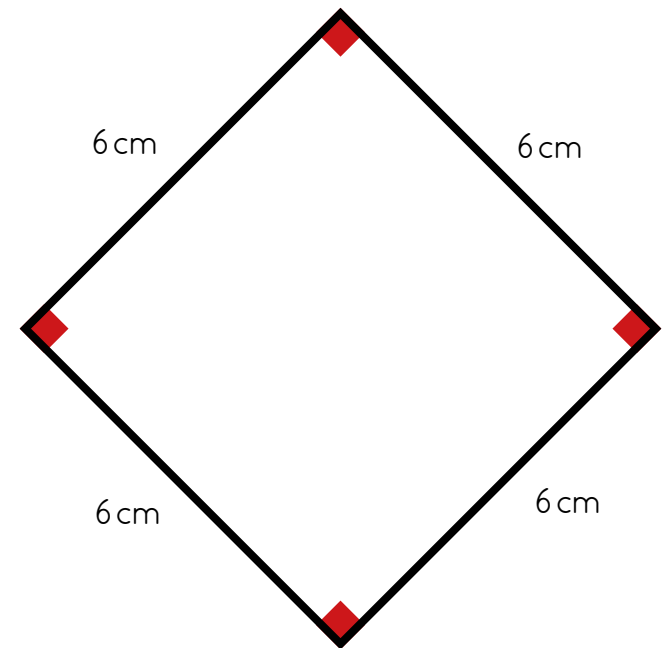
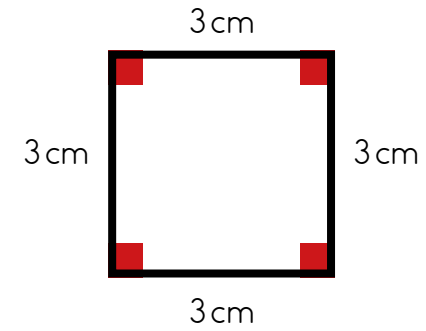



Indique les figures qui sont des carrés.

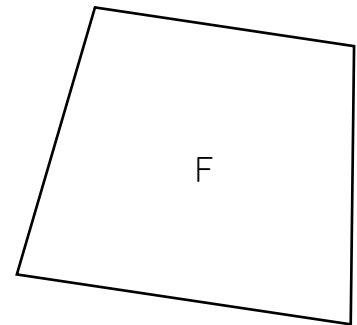
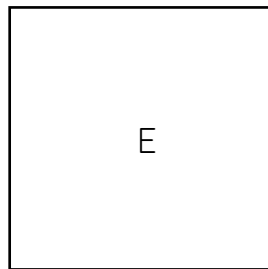
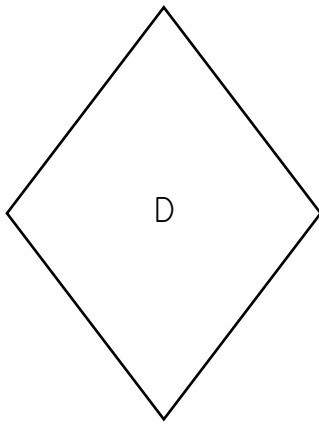
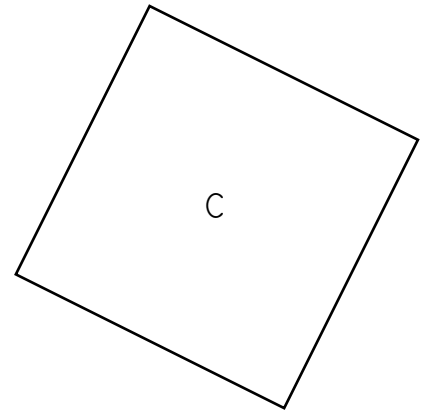
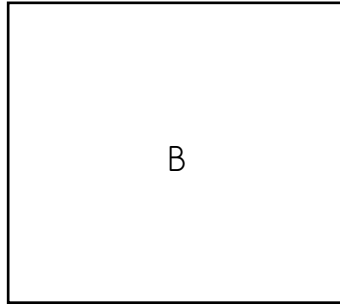
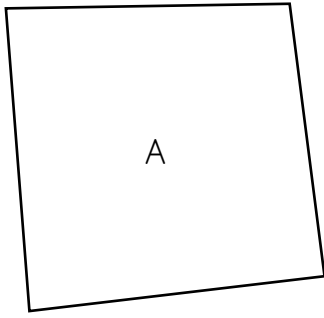

Indique les figures qui sont des carrés.

