

Construire les premiers outils
pour structurer sa pensée

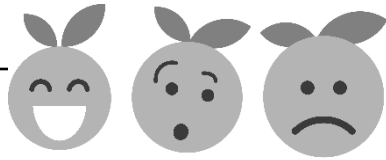

Consigne : Monsieur Lapin prépare de la soupe. Aidez-le en dessinant dans
chaque marmite le bon nombre de carottes.

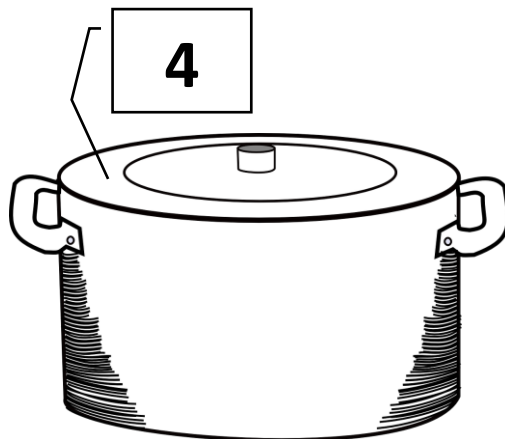

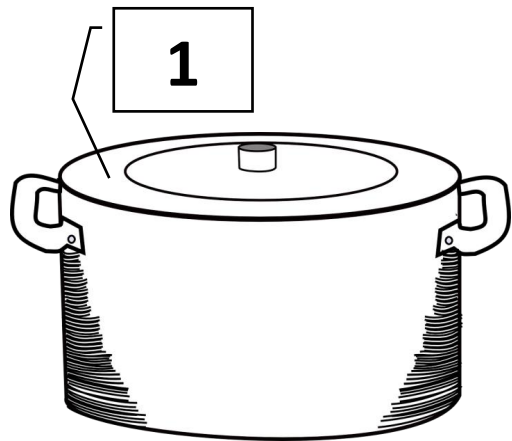
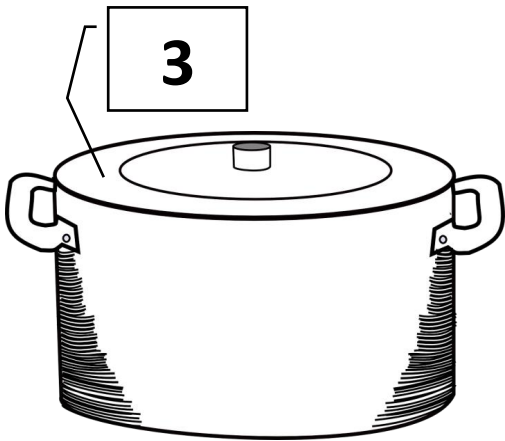
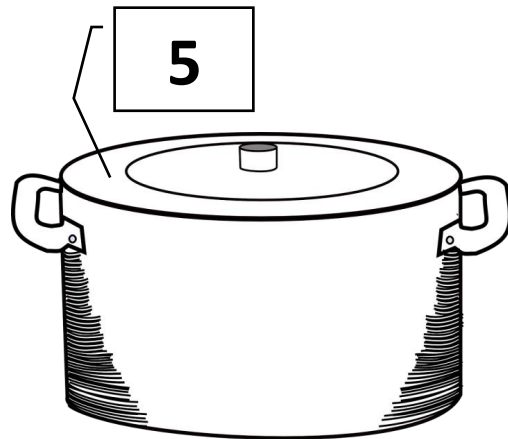
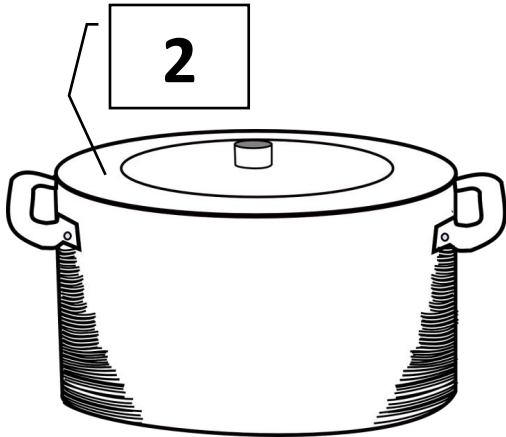
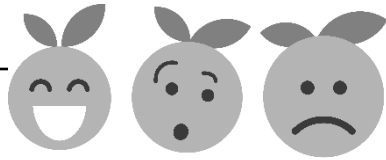

Construire les premiers outils
pour structurer sa pensée

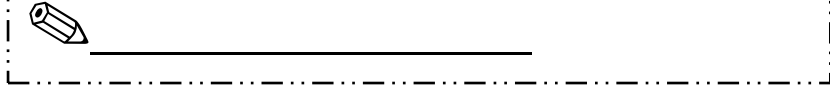

Consigne : Monsieur Lapin prépare de la soupe. Aide le en dessinant dans
chaque marmite le bon nombre de carottes.

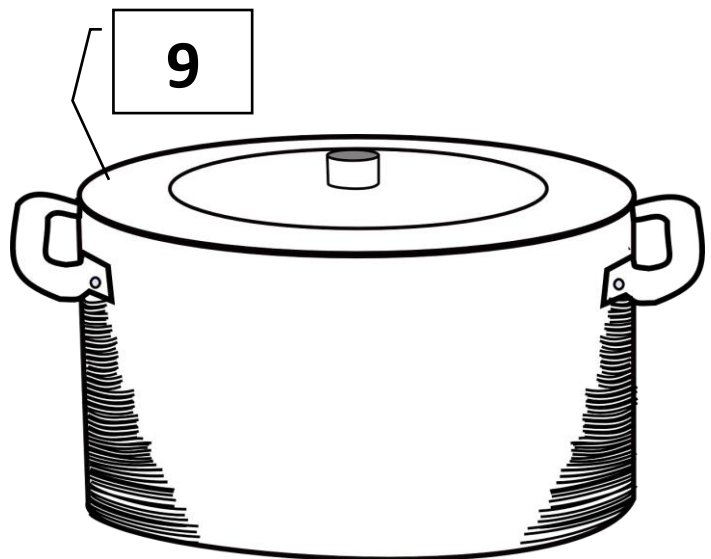
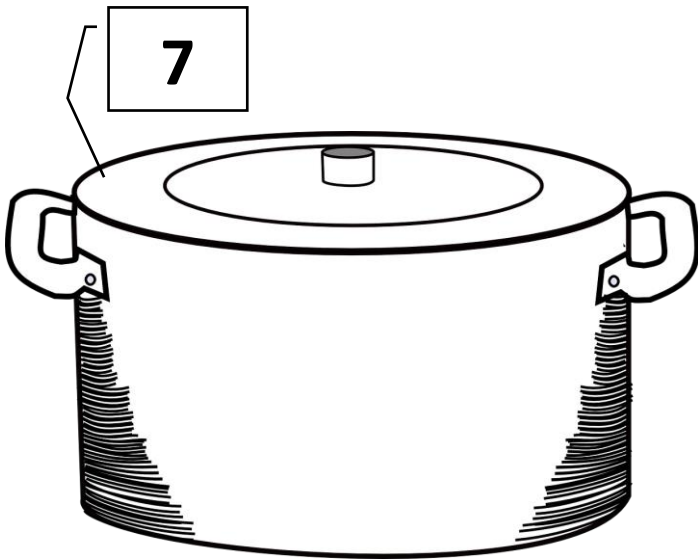
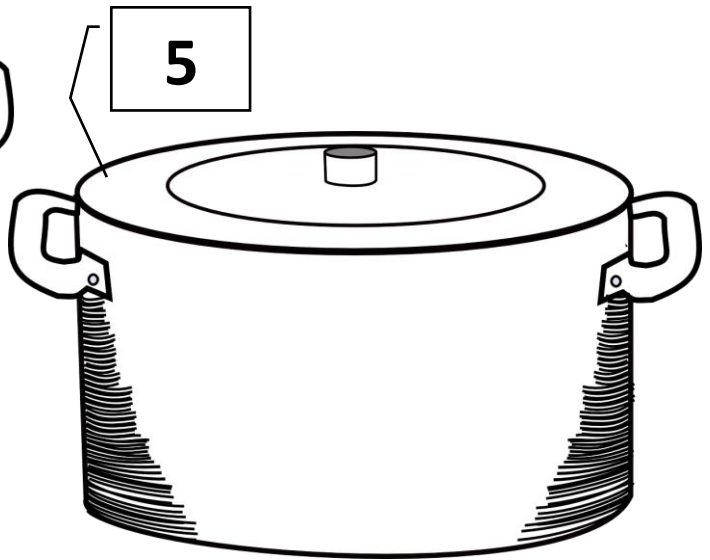
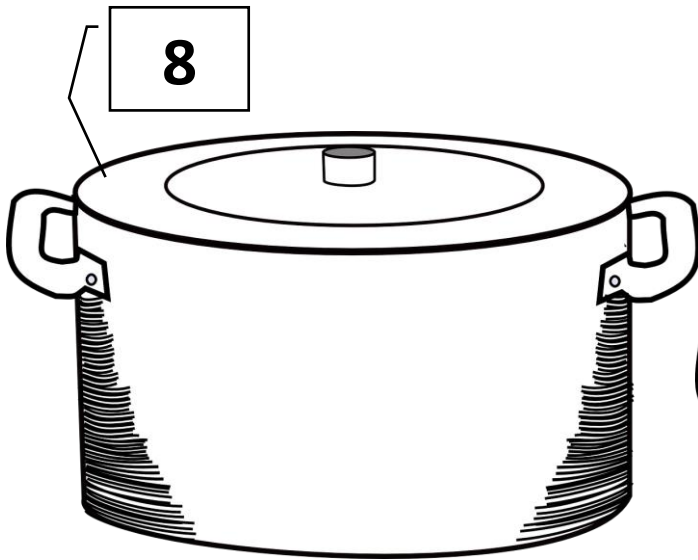

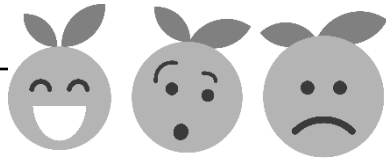

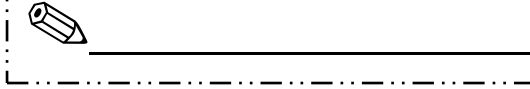
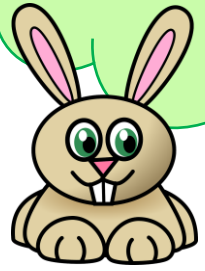

Construire les premiers outils
pour structurer sa pensée



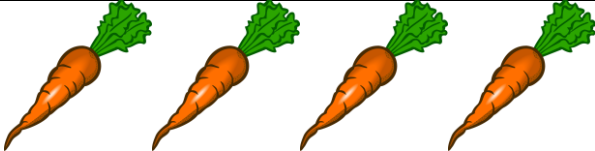
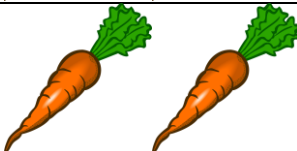
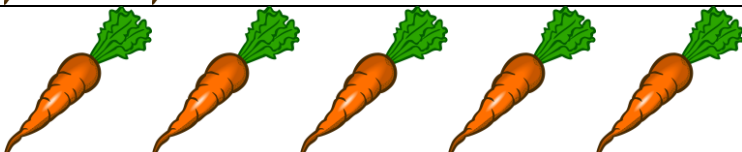
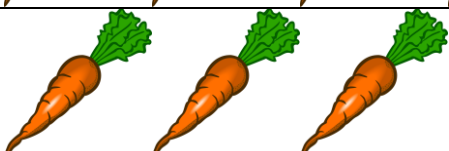
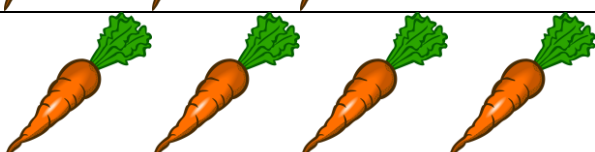
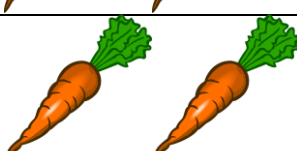
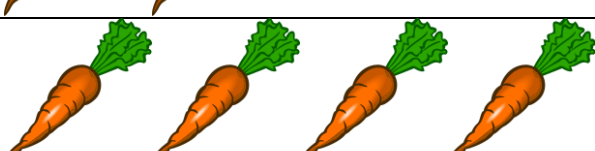
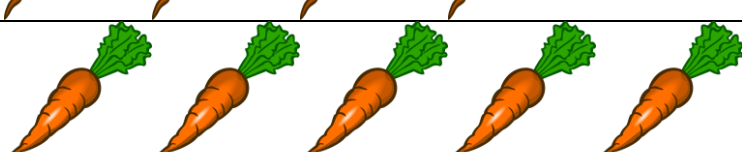

Consigne : Compte le nombre de carottes et colorie le chiffre qui correspond.

	3	5
	5	2
	3	4
	4	2
	5	3
	3	1
	2	4
	3	2
	2	4
	5	3

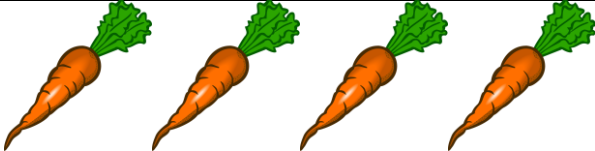
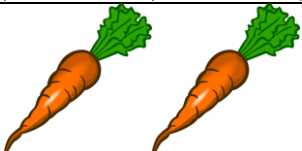
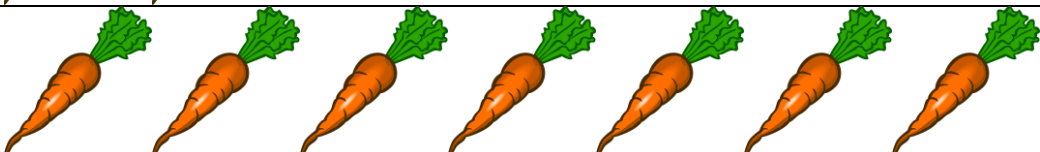
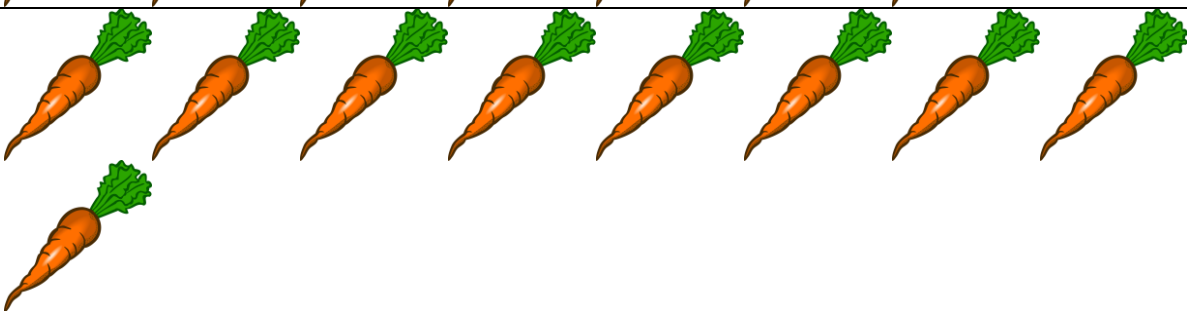
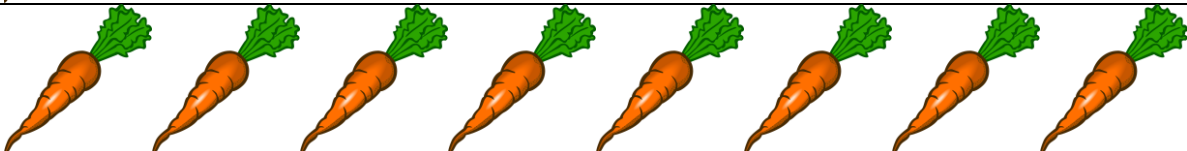
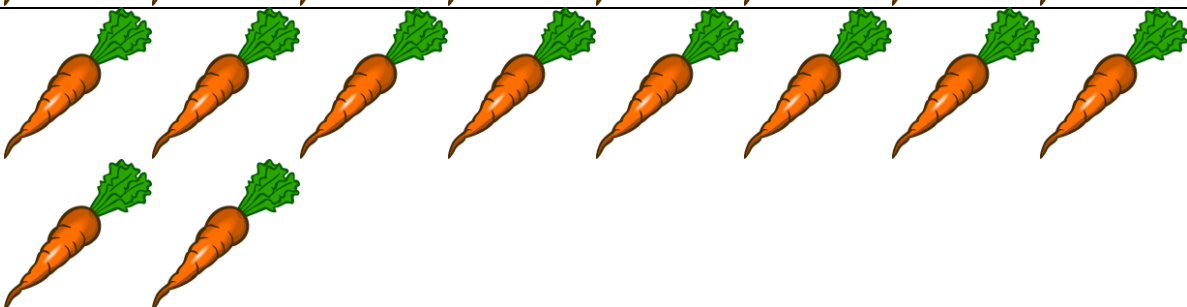

Consigne : Compte le nombre de carottes et colorie le chiffre qui correspond.

	3	5
	5	2
	3	4
	4	2
	5	7
	7	9
	4	8
	10	6



Consigne : Compte le nombre de carottes et écrit le chiffre qui correspond.

