

Prénom :

Date :









LECTURE : phonologie 1

Je suis capable de repérer un son identique dans plusieurs mots.

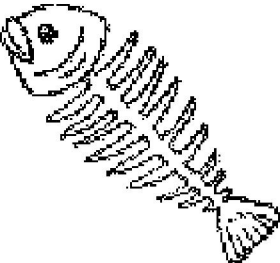
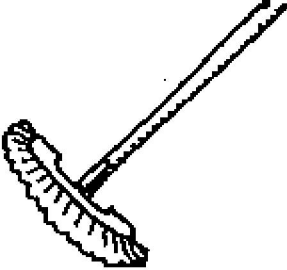
è - ê - ai - ei - et		
	règle	
	tête	
[è]	balai	
	treize	13
	poulet	

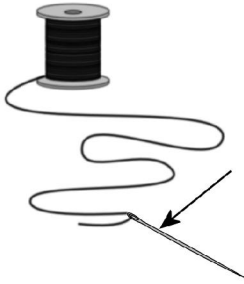
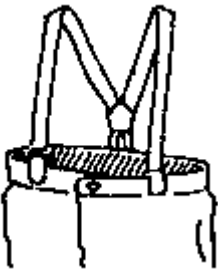
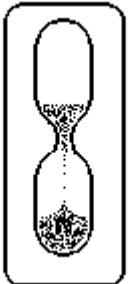

Je colorie l'image quand j'entends [è].



LECTURE : phonologie 2

Je suis capable de localiser un son dans un mot.



 è - ê - ai - ei - et		
	règle	   
[è]	tête	
	balai	
	treize	
	poulet	

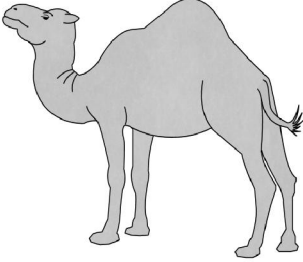

Je mets une croix où j'entends [è].

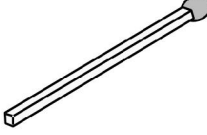
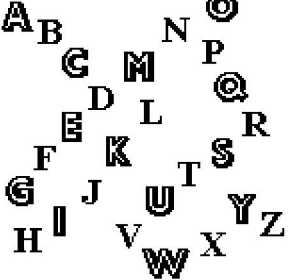
		
<input type="checkbox"/> <input type="checkbox"/> <input type="checkbox"/>	<input type="checkbox"/> <input type="checkbox"/> <input type="checkbox"/>	<input type="checkbox"/> <input type="checkbox"/> <input type="checkbox"/>

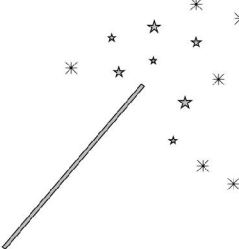
		
<input type="checkbox"/> <input type="checkbox"/> <input type="checkbox"/>	<input type="checkbox"/> <input type="checkbox"/> <input type="checkbox"/>	<input type="checkbox"/> <input type="checkbox"/> <input type="checkbox"/>

		
<input type="checkbox"/> <input type="checkbox"/> <input type="checkbox"/>	<input type="checkbox"/> <input type="checkbox"/> <input type="checkbox"/> <input type="checkbox"/>	<input type="checkbox"/> <input type="checkbox"/> <input type="checkbox"/>

Prénom :

Date :

	è - ê - ai - ei - et	
	règle	
[è]	tête	
	balai	
	treize	13
	poulet	

LECTURE :

discrimination visuelle

Je connais les lettres de l'alphabet.

Je connais les correspondances entre minuscules et majuscules d'imprimerie et majuscules et minuscules cursives.



J'entoure quand je vois la lettre è .

é è ë ê è é
 è ê è é ë è
 é ë ê è é è



J'entoure les mots où je vois la lettre è.

tombé Noël élève
 école règle été
 gèle zèbre réelle



Je colorie les mots identiques de la même couleur.

MAIS	taie	LAIT
mais	RAIS	lait
taie	rais	TAIE
mais	lait	rais

LECTURE : combinatoire

 è - ê - ai - ei - et
 règle
 [è] tête
 balai
 treize
 poulet



 13



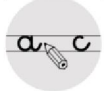

Je suis capable de repérer les syllabes d'un mot.
 Je suis capable d'organiser des syllabes pour construire un mot.

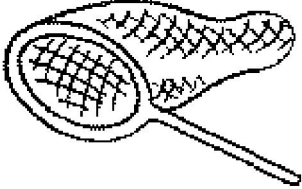

Je complète les mots avec : let, net, vet, bei

		
a _ _ _ lle	na _ _ _	car _ _ _

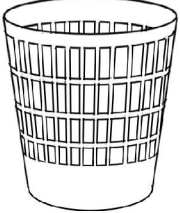
		
fi _ _ _	cha _ _ _	cor _ _ _ lle

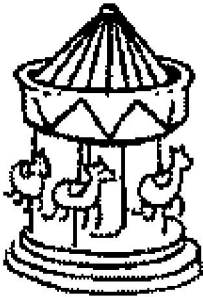
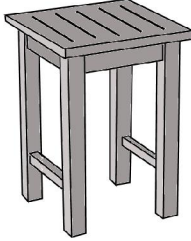

Je reconstruis les mots avec les syllabes.

ge	ma	nè	ret	bou	ta
					
_ _ _ _ _			_ _ _ _ _		