

Prénom :

Date :









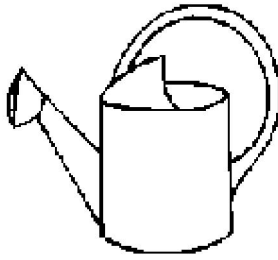
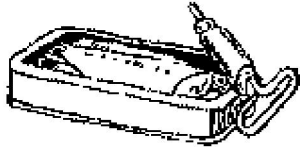

	S s P p	
	SAPIN	
[s]	sapin	
	sapin	

LECTURE : phonologie 1

Je suis capable de repérer un son identique dans plusieurs mots.

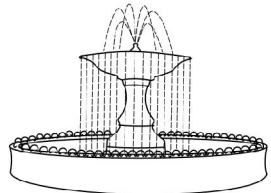

J'entoure l'image quand j'entends [s].



LECTURE : phonologie 2



	S s P p	
	SAPIN	
[s]	sapin	
	sapin	

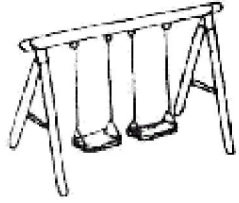

Je suis capable de localiser un son dans un mot.



Je mets une croix où j'entends [s].

		
<input type="checkbox"/> <input type="checkbox"/> <input type="checkbox"/>	<input type="checkbox"/> <input type="checkbox"/> <input type="checkbox"/>	<input type="checkbox"/> <input type="checkbox"/> <input type="checkbox"/>

		
<input type="checkbox"/> <input type="checkbox"/> <input type="checkbox"/>	<input type="checkbox"/> <input type="checkbox"/> <input type="checkbox"/>	<input type="checkbox"/> <input type="checkbox"/> <input type="checkbox"/> <input type="checkbox"/>

		
<input type="checkbox"/> <input type="checkbox"/> <input type="checkbox"/>	<input type="checkbox"/> <input type="checkbox"/> <input type="checkbox"/>	<input type="checkbox"/> <input type="checkbox"/> <input type="checkbox"/>

Prénom :

Date :



LECTURE :

discrimination visuelle

Je connais les lettres de l'alphabet.

Je connais les correspondances entre minuscules et majuscules d'imprimerie et majuscules et minuscules cursives.



J'entoure quand je vois S.

S G C S Z S

Z C S S y S

s r n s z s



J'entoure les mots où je vois S.

SEMAINE RADIS ZEBRE

remorque mars sabre

seconde rasoir revoyez



Je colorie les mots identiques de la même couleur.

SANS	sons	SEINS
seins	SENS	sens
seins	sans	SONS
sens	sans	sons



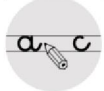

LECTURE : combinatoire

 S s P p		
 [s]	SAPIN sapin sapin	

Je suis capable de repérer les syllabes d'un mot.
 Je suis capable d'organiser des syllabes pour construire un mot.

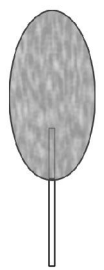
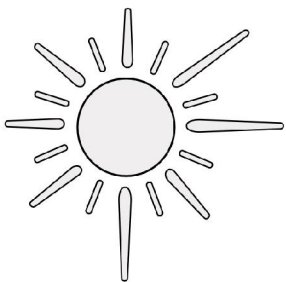
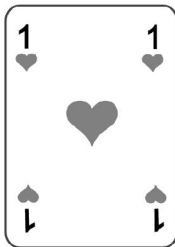

Je complète les mots avec : as os sa su so si

		
_ _ bat	_ _ flet	_ _ cette
		
_ _ leil	_ _	_ _

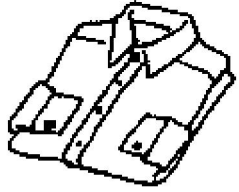

Je reconstruis les mots avec les syllabes.

la	sa	de	che	se	mi
					
_ _ _ _ _			_ _ _ _ _		