



Prénom : .....

Date : .....

## LECTURE : phonologie 1

*Je suis capable de repérer un son identique dans plusieurs mots*



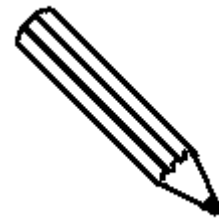
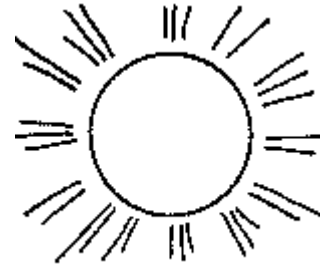

O o O o		
 [o]	POT pot pot	
		

 J'entoure l'image quand j'entends [o].





# LECTURE : phonologie 2



Je suis capable de localiser un son dans un mot

	○ ○ ○ ○ ○	
	POT	
[o]	pot	
	pot	

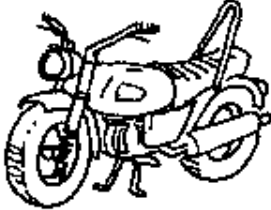

Je mets une croix où j'entends [o].

		
<input type="checkbox"/> <input type="checkbox"/> <input type="checkbox"/>	<input type="checkbox"/> <input type="checkbox"/>	<input type="checkbox"/> <input type="checkbox"/> <input type="checkbox"/>

		
<input type="checkbox"/> <input type="checkbox"/>	<input type="checkbox"/> <input type="checkbox"/>	<input type="checkbox"/> <input type="checkbox"/> <input type="checkbox"/> <input type="checkbox"/>

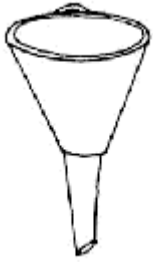
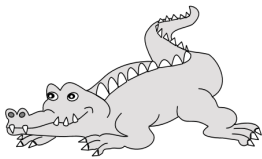
		
<input type="checkbox"/> <input type="checkbox"/> <input type="checkbox"/>	<input type="checkbox"/> <input type="checkbox"/> <input type="checkbox"/>	<input type="checkbox"/> <input type="checkbox"/> <input type="checkbox"/>

Prénom : .....

Date : .....

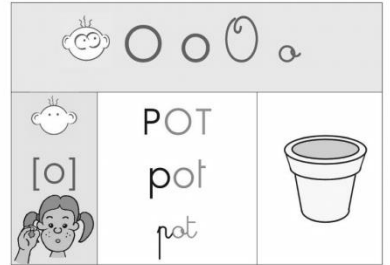

### LECTURE : discrimination visuelle

*Je connais les lettres de l'alphabet.*

*Je connais les correspondances entre minuscules et majuscules d'imprimerie et majuscules et minuscules cursives.*



J'entoure quand je vois O.

p o d b o a o g  
P Q O U B C O D  
a o g d q a e a  
O Q P g O D e O



J'entoure les mots où je vois O.

ballon pantalon panda quatre on  
QUINZE OPERA GARAGE BALLE PONT  
goudron pinceau tuyau mordre case ton



Je colorie les mots identiques de la même couleur.

auto	moto	moto
MOI	auto	toit
TOIT	toit	moi
moi	MOTO	AUTO