

ATELIER « ENRICHIR UN GN »

DÉROULEMENT DE L'ATELIER

1- JE CHOISIS UN VÊTEMENT OU UN ACCESSOIRE.

2- JE LE DÉCORE AVEC DES FORMES, DES COULEURS , DES MOTIFS, OU DES DESSINS.

3- J'ÉCRIS POUR PRÉCISER COMMENT EST MON VÊTEMENT OU MON ACCESSOIRE.

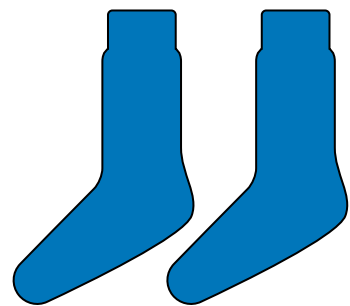
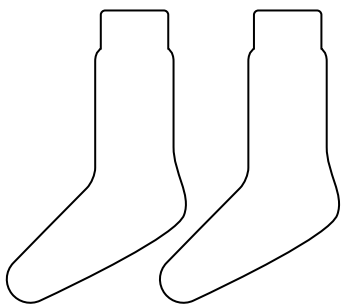

des chaussettes —> des chaussettes bleues

VARIANTES DE L'ATELIER

1- JE CHOISIS UN VÊTEMENT OU UN ACCESSOIRE.

2- JE PIOCHE UNE CARTE « CONTRAINTE D'ÉCRITURE »

3- JE LE DÉCORE AVEC DES FORMES, DES COULEURS , DES MOTIFS, OU DES DESSINS.

3- J'ÉCRIS POUR PRÉCISER COMMENT EST MON VÊTEMENT OU MON ACCESSOIRE EN RESPECTANT LA CONTRAINTE

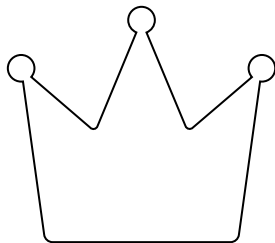

+

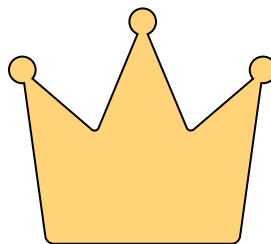
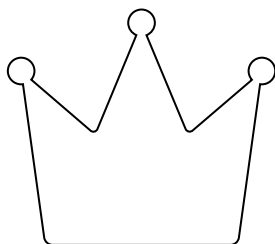
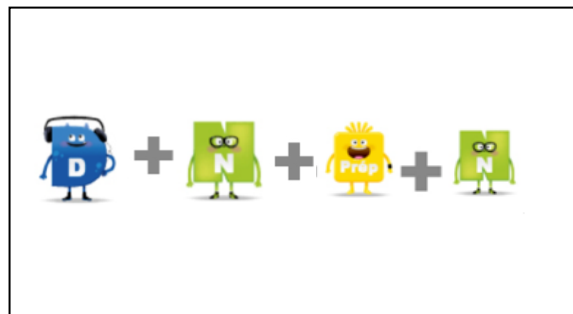

une couronne

—> une couronne en or

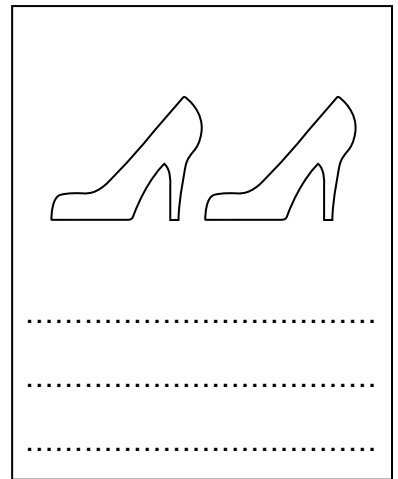
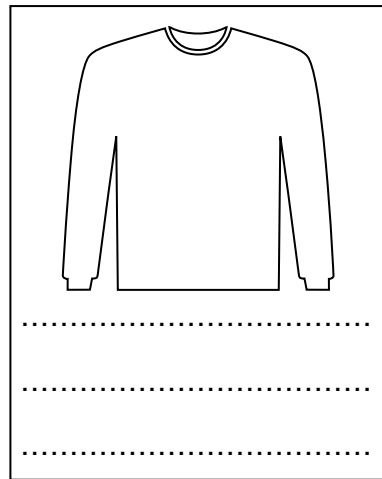
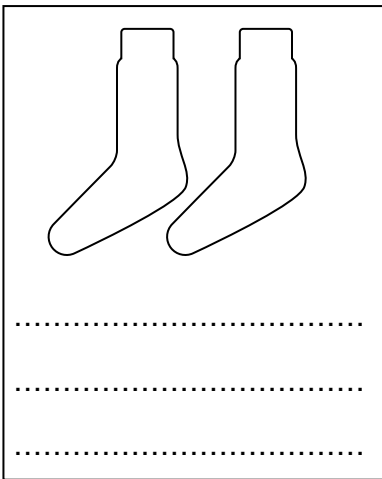
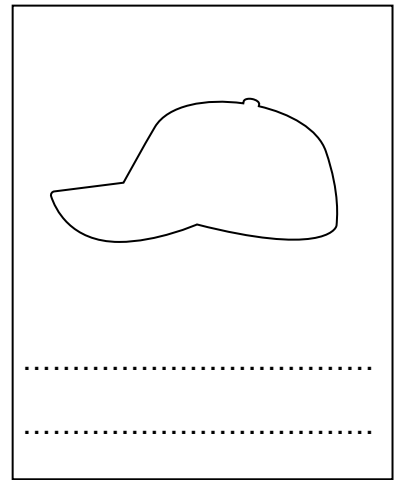
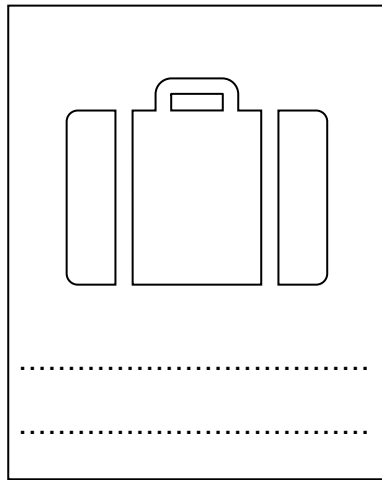
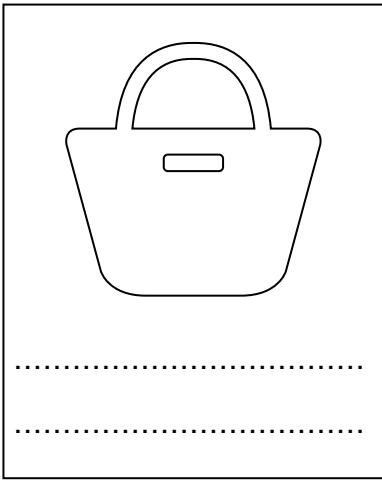
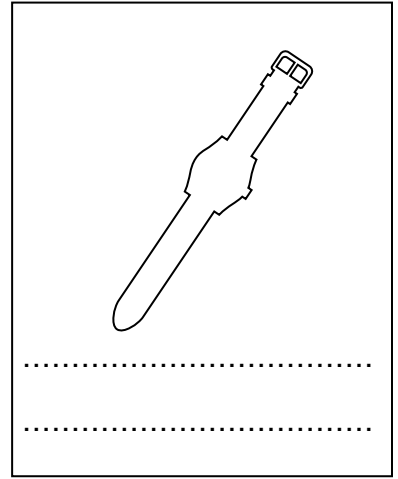
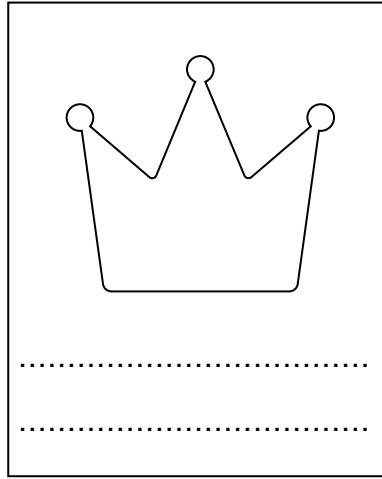
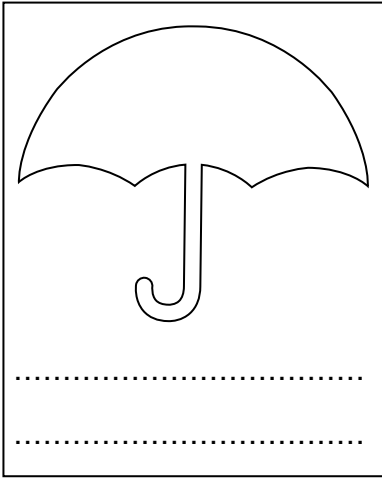
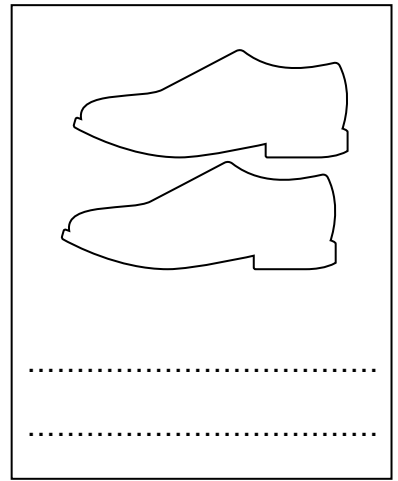
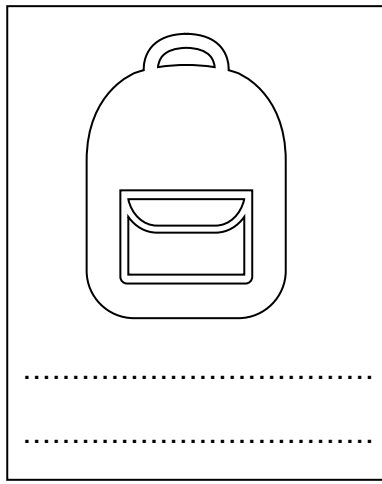
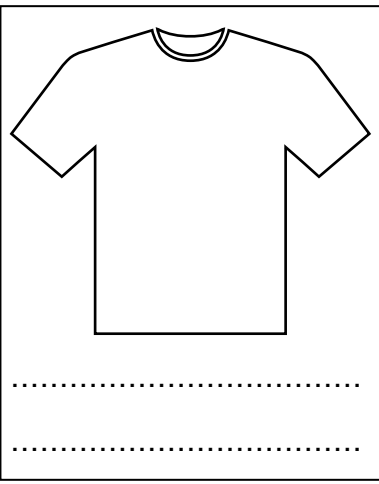

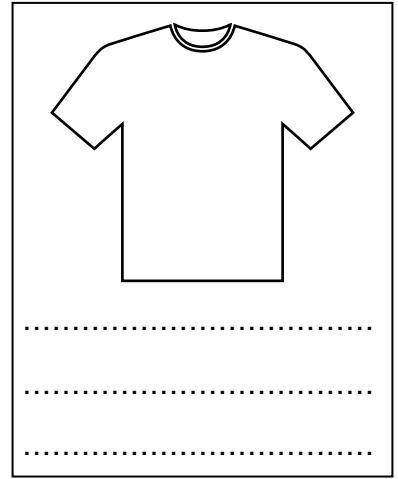
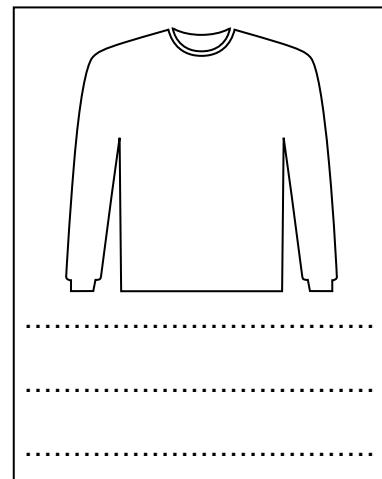
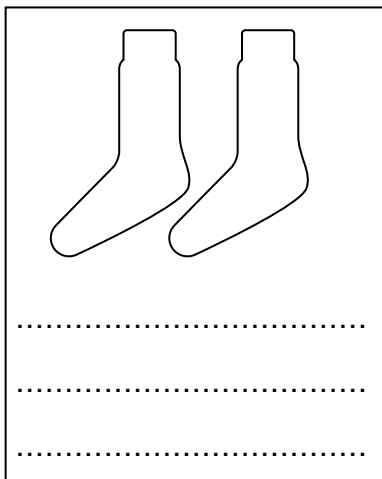
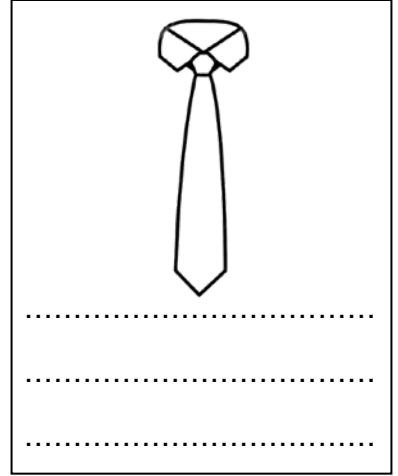
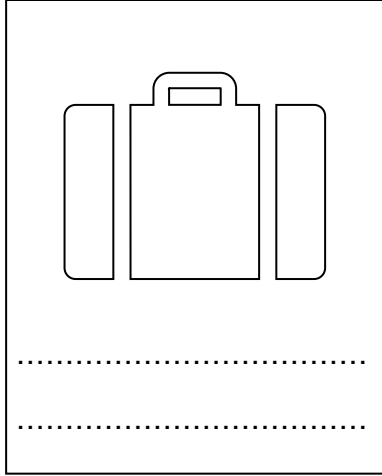
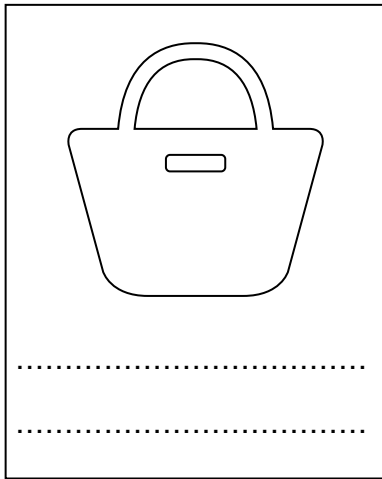
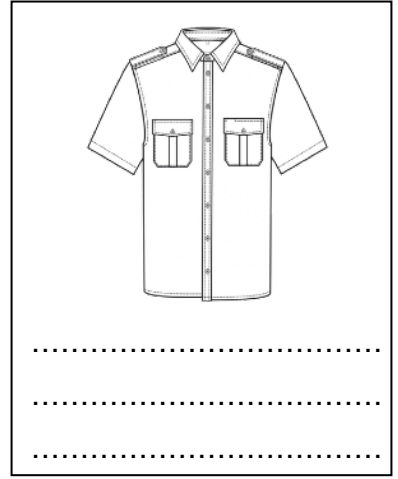
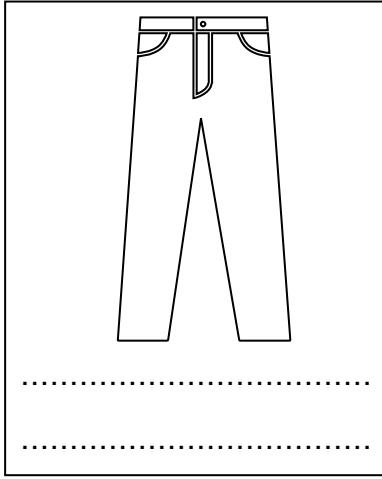
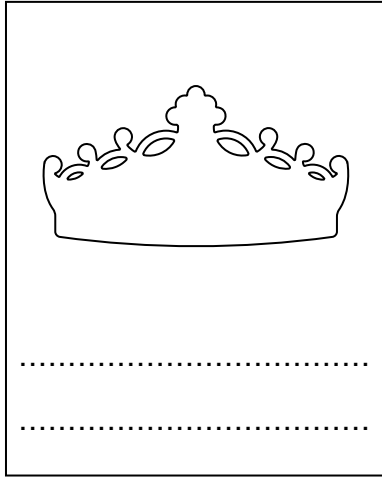
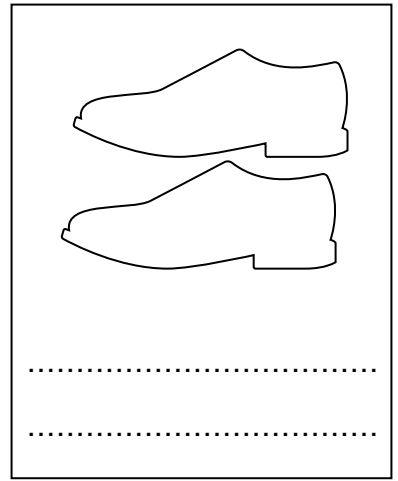
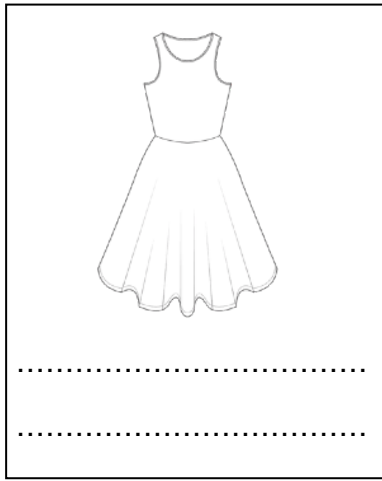
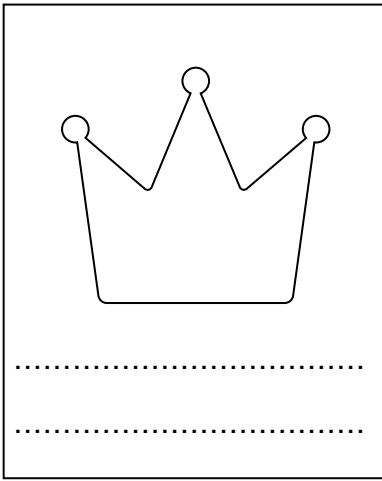



**CONTRAINTE
D'ÉCRITURE**

**CONTRAINTE
D'ÉCRITURE**

**CONTRAINTE
D'ÉCRITURE**

**CONTRAINTE
D'ÉCRITURE**

**CONTRAINTE
D'ÉCRITURE**

**CONTRAINTE
D'ÉCRITURE**

**CONTRAINTE
D'ÉCRITURE**

**CONTRAINTE
D'ÉCRITURE**

**CONTRAINTE
D'ÉCRITURE**

**CONTRAINTE
D'ÉCRITURE**

**CONTRAINTE
D'ÉCRITURE**

**CONTRAINTE
D'ÉCRITURE**