





Prénom : .....

Date : .....

## LECTURE : phonologie 1

*Je suis capable de repérer un son identique dans plusieurs mots*

	T t T t	
 [t]	tapis tapis tapis	
		

J'entoure l'image quand j'entends [t].

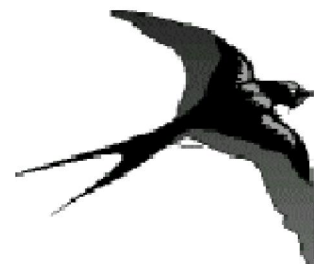
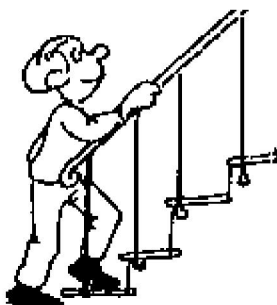
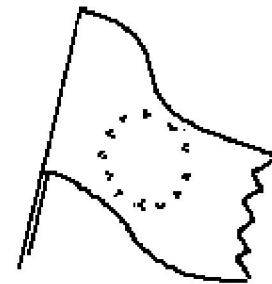
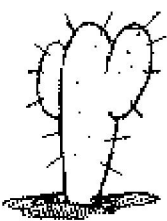
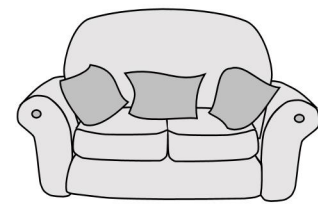
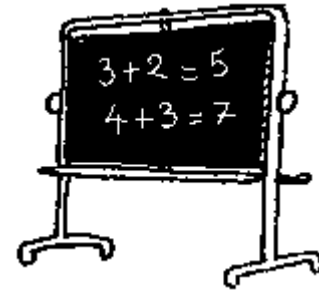
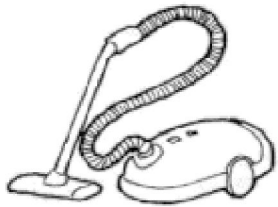







# LECTURE : phonologie 2

Je suis capable de localiser un son dans un mot

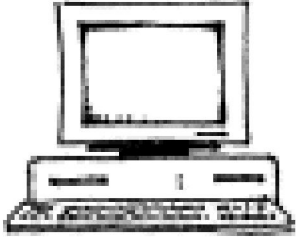

Je mets une croix où j'entends [t].

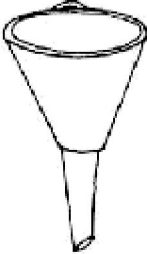

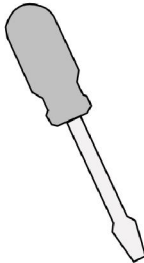
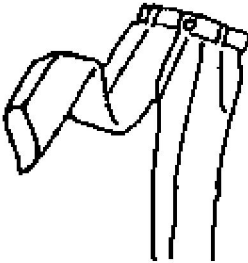

		
<input type="checkbox"/> <input type="checkbox"/> <input type="checkbox"/> <input type="checkbox"/>	<input type="checkbox"/> <input type="checkbox"/> <input type="checkbox"/>	<input type="checkbox"/> <input type="checkbox"/> <input type="checkbox"/> <input type="checkbox"/>

		
<input type="checkbox"/> <input type="checkbox"/> <input type="checkbox"/> <input type="checkbox"/>	<input type="checkbox"/> <input type="checkbox"/> <input type="checkbox"/>	<input type="checkbox"/> <input type="checkbox"/> <input type="checkbox"/>

		
<input type="checkbox"/> <input type="checkbox"/> <input type="checkbox"/>	<input type="checkbox"/> <input type="checkbox"/> <input type="checkbox"/>	<input type="checkbox"/> <input type="checkbox"/> <input type="checkbox"/>

Prénom : .....

Date : .....

	T t T t
 [t]	tapis tapis tapis
	

### LECTURE : discrimination visuelle

*Je connais les lettres de l'alphabet.*

*Je connais les correspondances entre minuscules et majuscules d'imprimerie et majuscules et minuscules cursives.*

 J'entoure quand je vois T.

L F Y D K H T T P

t l f d t g j k t

q t p y d l h t

 J'entoure les mots où je vois T.

PANTALON BALLON CHEMISE CHAPEAU ELEPHANT

adorer embrasser appartement plateau quatre

jolie talon lampe étonner plomb attaque pas

 Je colorie les mots identiques de la même couleur.

tape	TAPAS	tate
tapas	trape	tapas
TRAPE	tape	tate
TATE	TAPE	trape

# LECTURE : combinatoire

Je suis capable de repérer les syllabes d'un mot.

Je suis capable d'organiser des syllabes pour construire un mot.



Je complète les mots avec : ta , ti , to , tu , te

	T t C t	
	tapis	
[t]	tapis	
	tapis	

po ___ ron	bot ___ s	cac ___ s

car ___ ble	___ meau	___ roir

Je reconstruis les mots avec les syllabes.

tue	tor	tou	pie
_____		_____	

