

Cahier évaluations des compétences

Semestre 1- MS

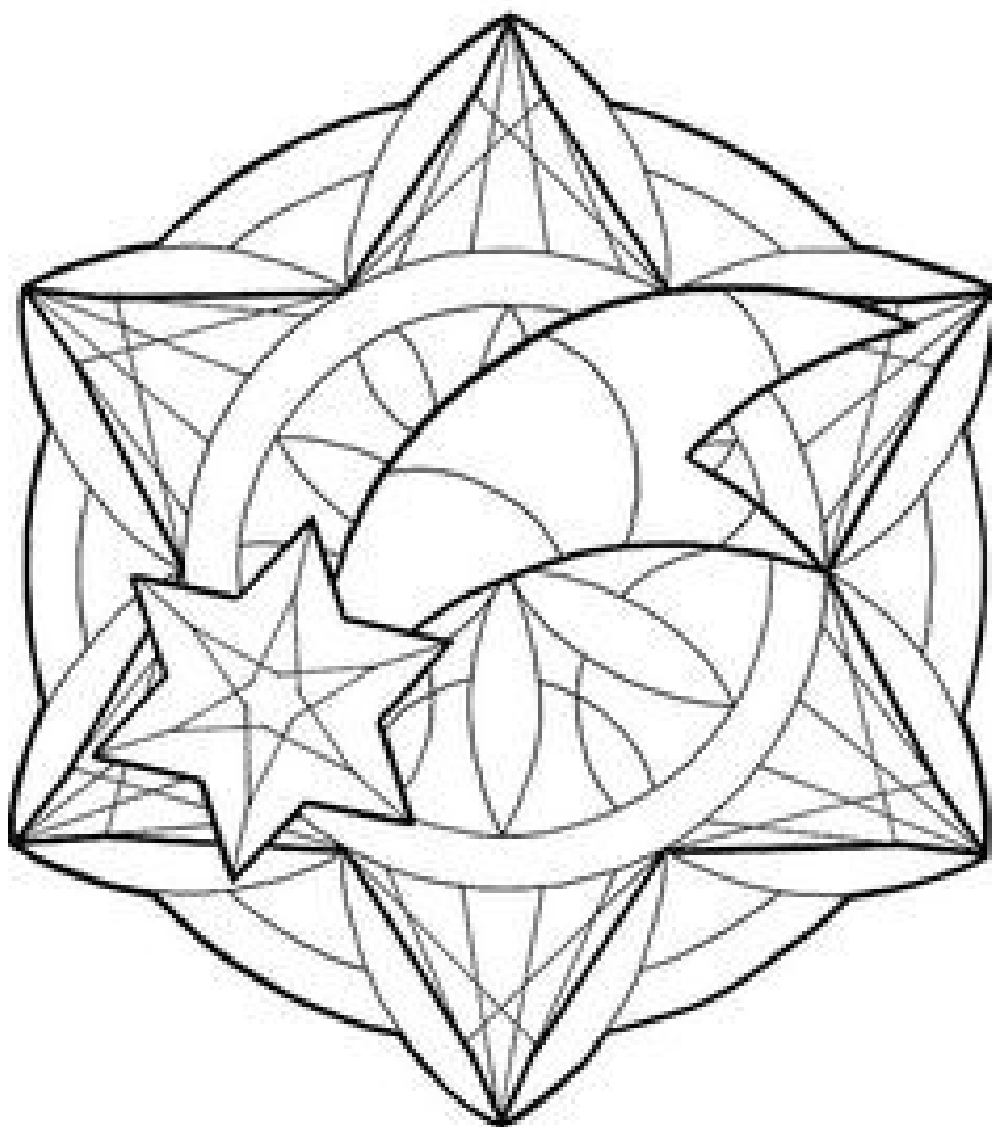

Prénom : _____

Compétence : Dénumérer les syllabes d'un mot.

Consigne : Coller autant de gommettes qu'il y a de syllabes dans le mot.

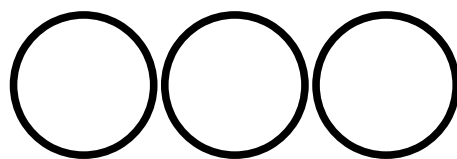
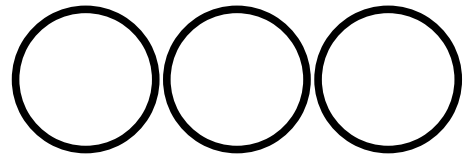
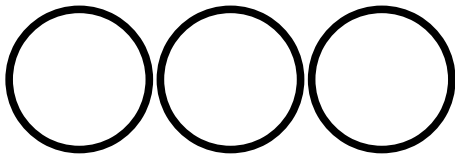
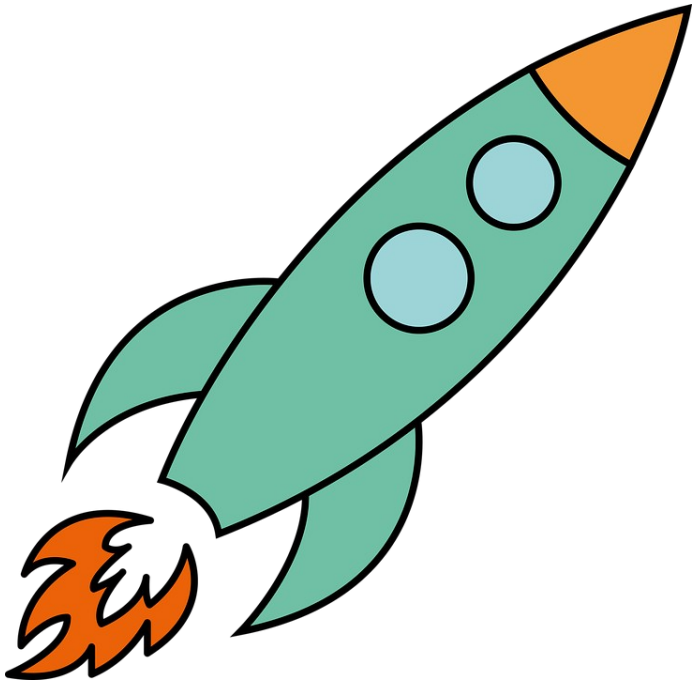

Validation :



Commentaire :

Compétence : Reconnaître des personnages connus.

Consigne : Nomme les personnages que nous avons rencontré durant l'année.

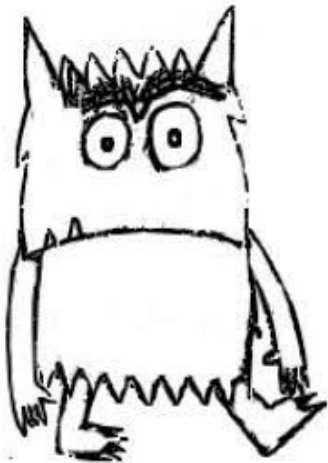

Monstre des couleurs



M. Costaud



Mme Lumineuse

Validation :



Commentaire :

Compétence : Reconnaître son prénom.

Consigne : Colorie ton prénom.

AMED FELIPE

PAUL MADDY

NOA RAPHAEL

LEO

LOONA

LEONEL

THIBAUD

Validation :



Commentaire :

Compétence : Nommer les lettres de son prénom. (Cette compétence est un bilan des acquis, elle ne sera validée qu'au semestre 2 dans le carnet).

Consigne : Nomme les lettres capitales qui forment ton prénom.

AMED FELIPE

PAUL MADDY

NOA RAPHAEL

LEO

LOONA

LEONEL

THIBAUD

Validation :



Commentaire :

Compétence : Reconnaître une lettre d'après un modèle.

Consigne : Colle les lettres correspondantes afin de reformer les mots.

| | | | |
|---|---|---|---|
| L | U | N | E |
| | | | |

| | | | | |
|---|---|---|---|---|
| T | E | R | R | E |
| | | | | |

| | | | | | |
|---|---|---|---|---|---|
| S | O | L | E | I | L |
| | | | | | |

Validation : 

Commentaire : _____

Compétence : Lire les lettres capitales. (Cette compétence est un bilan des acquis, elle ne sera validée qu'au semestre 2).

Consigne : Nommer les lettres que montre la maîtresse.

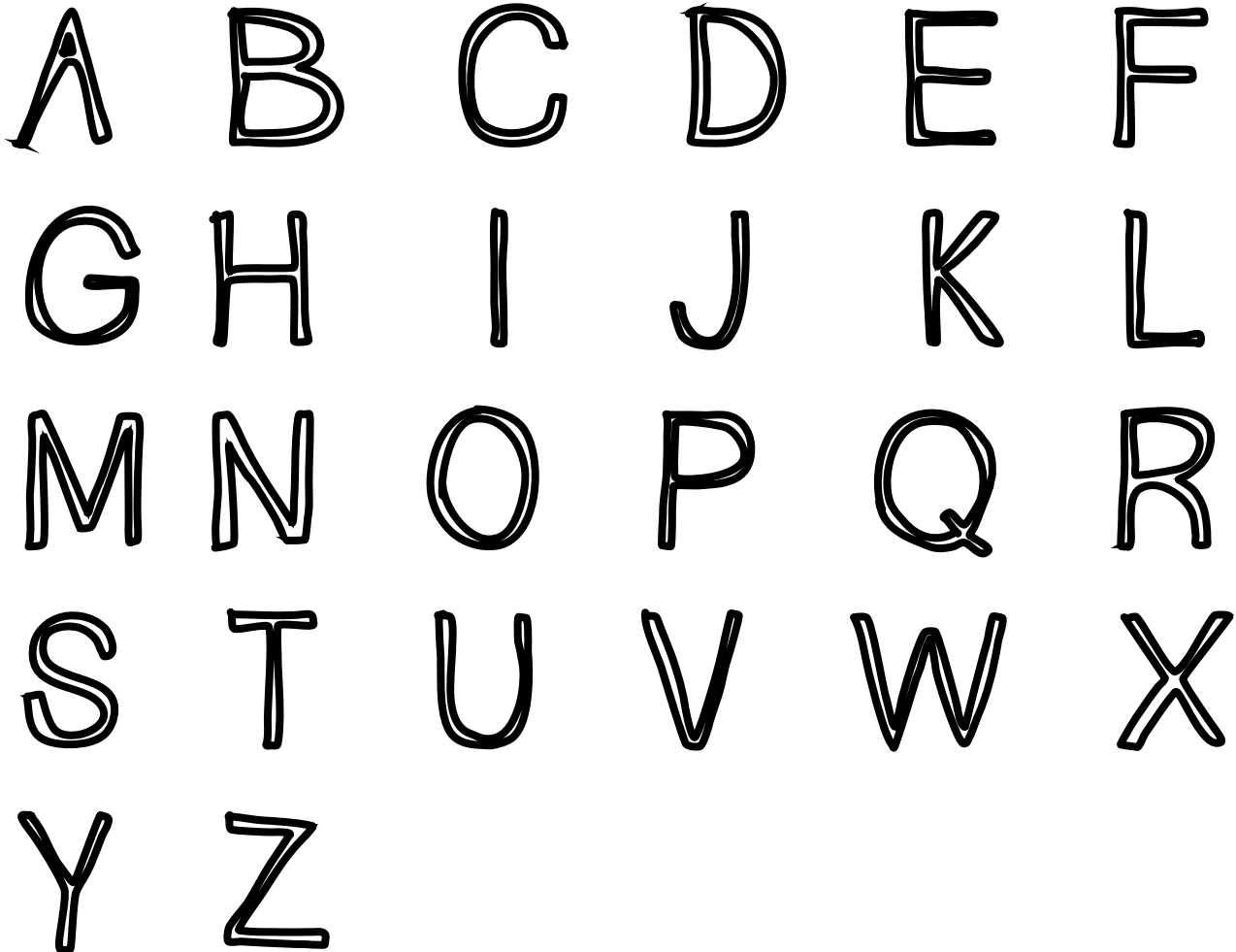

Validation : 

Commentaire : _____

Compétence : Reconnaître son prénom en écriture scripte. (Cette compétence est un bilan des acquis, elle ne sera validée qu'au semestre 2).

Consigne : Colle les lettres correspondantes afin de reformer les mots.

thibaud

léo

noa

raphaël

léonel

amed

louna

maddy

félipé

paul

Validation :



Commentaire :

Compétences : Découper avec soin. Découper sur une ligne.
Coller avec soin.

Consigne : Découper les filaments de l'étoile filante.

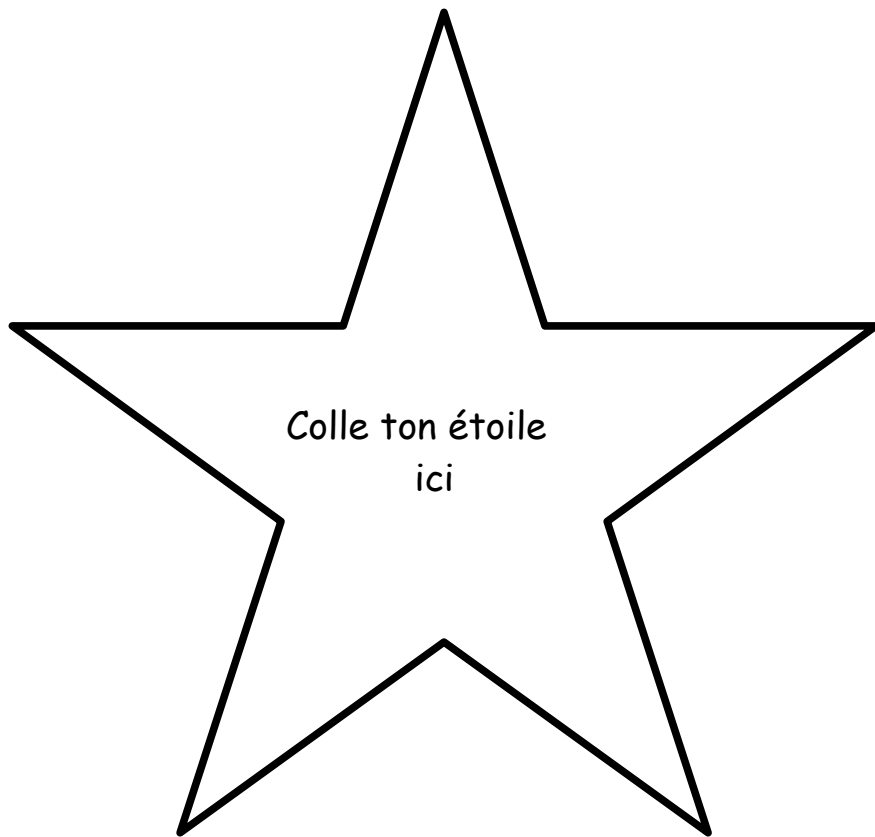

Validation : 

Commentaire : _____

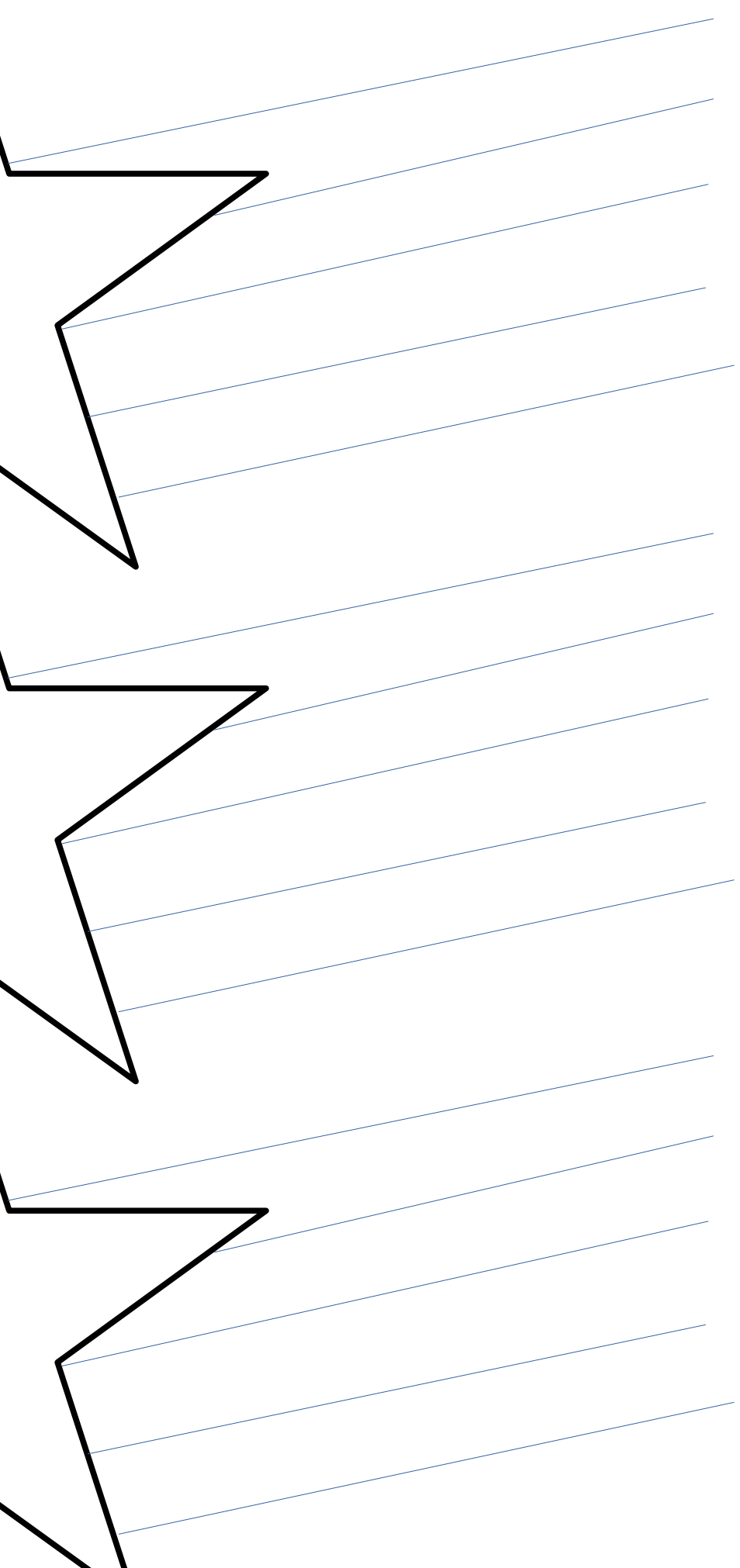
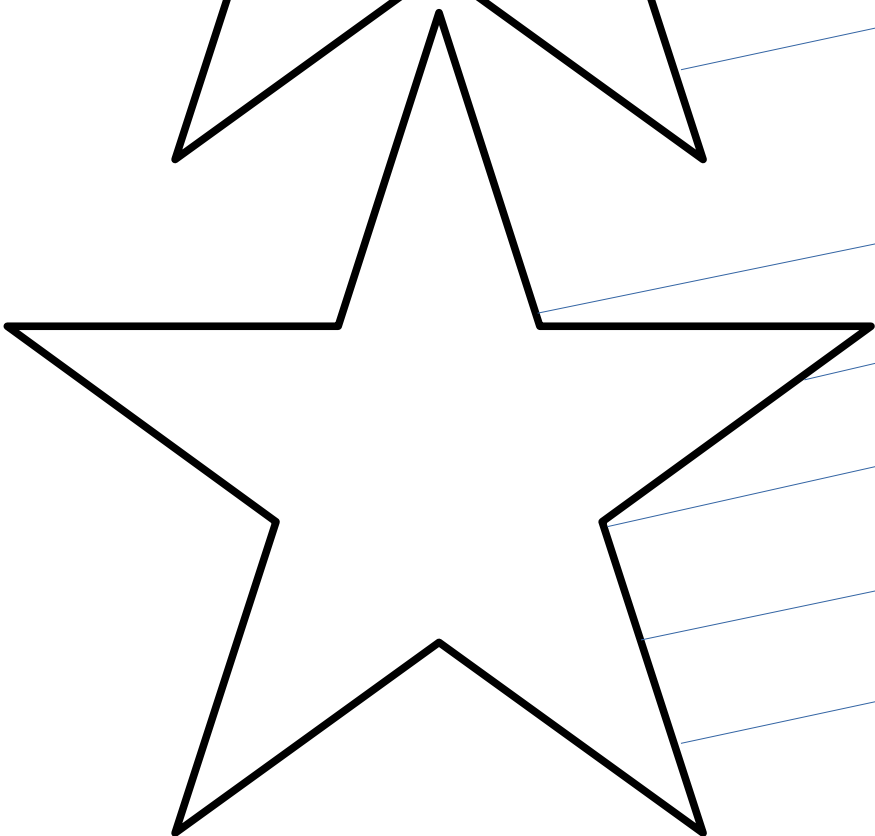
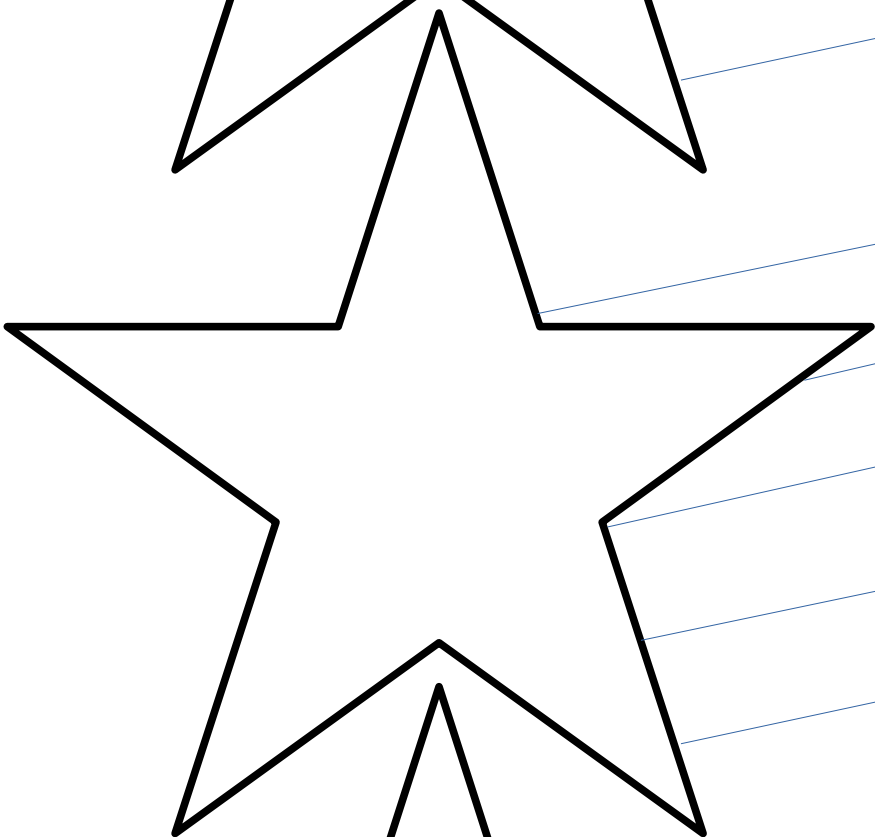
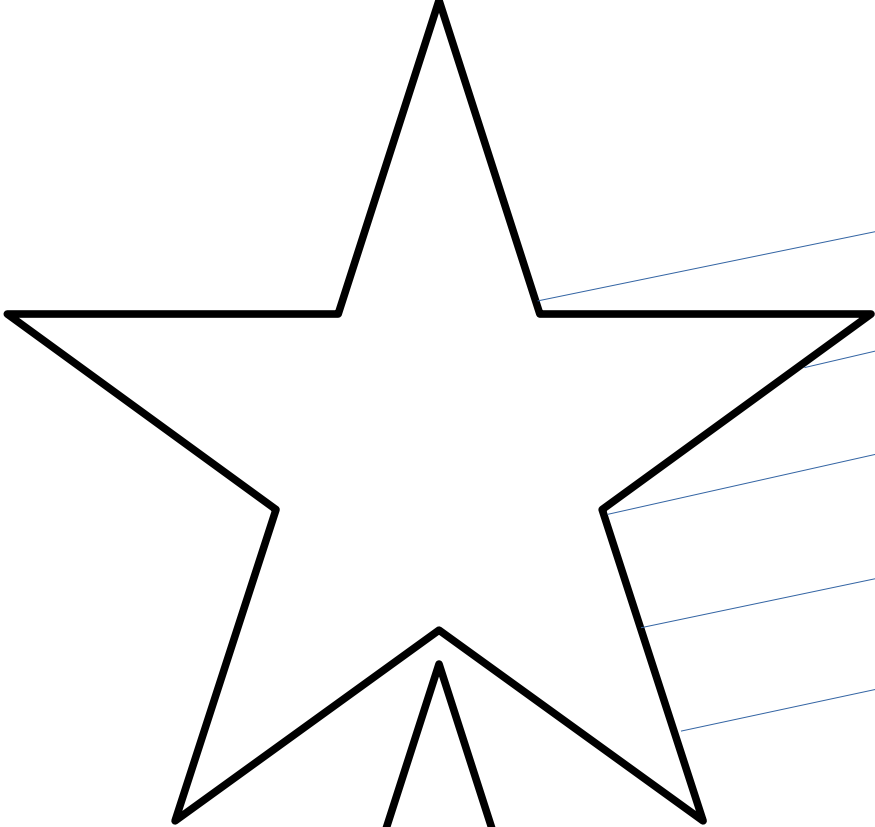

Compétences : Colorier avec soin.

Bien tenir son crayon.

Consigne : Colorie proprement et sans dépasser.

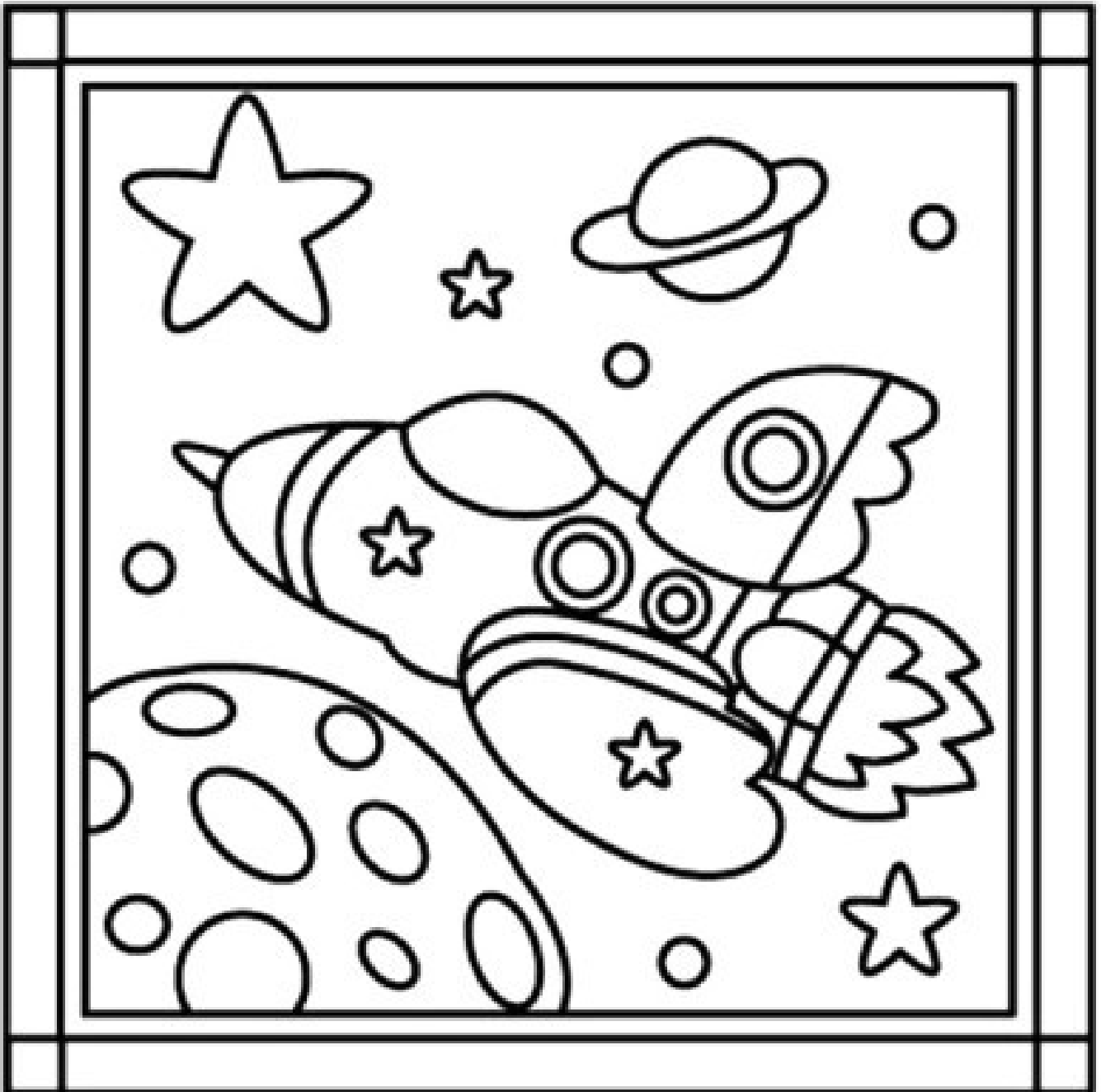

Validation : 

Commentaire : _____

Compétence : Ecrire des mots en majuscules. (Cette compétence est un bilan des acquis, elle ne sera validée qu'au semestre 2).

Consigne : Recopier les mots.

ETOILE

FILANTE

LUNE

Validation : 

Commentaire : _____

Compétence : Tracer des points, des lignes verticales et horizontales.

Consigne : Reproduis les graphismes dans les étoiles.

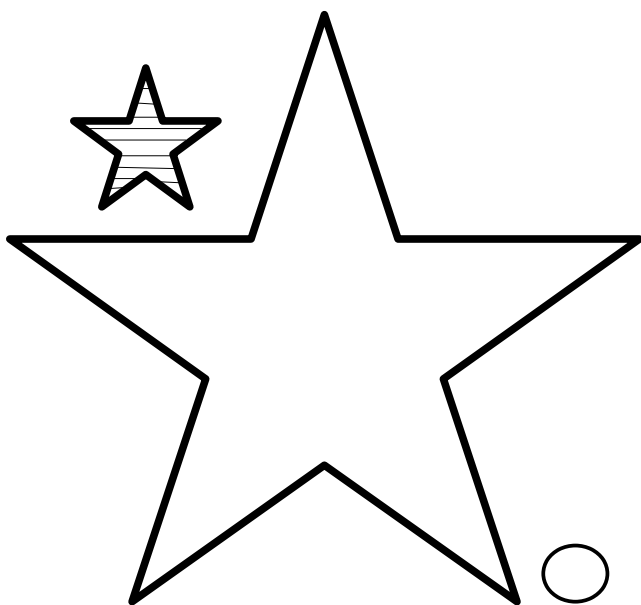
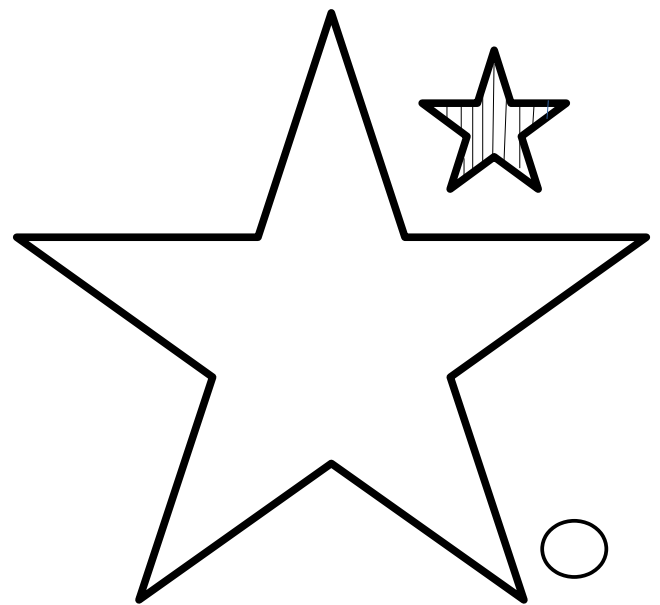
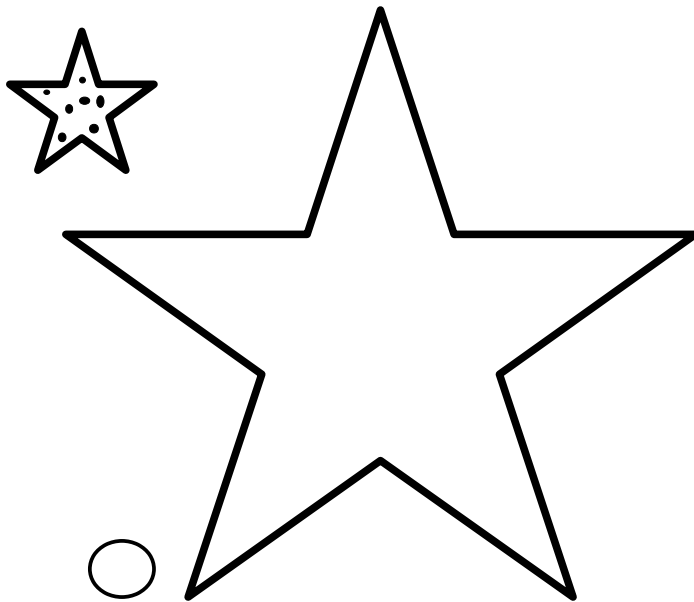

Validation : 

Commentaire : _____

Compétence : Tracer des ronds, des lignes brisées et des lignes obliques.

Consigne : Reproduis les graphismes dans les étoiles.

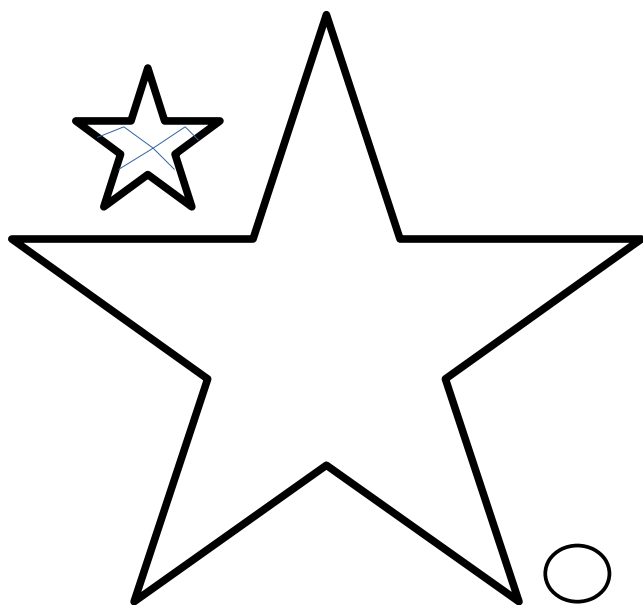
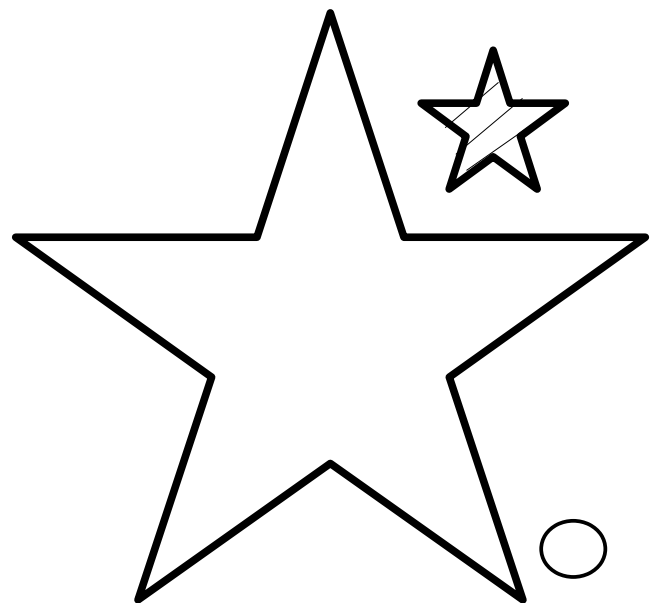
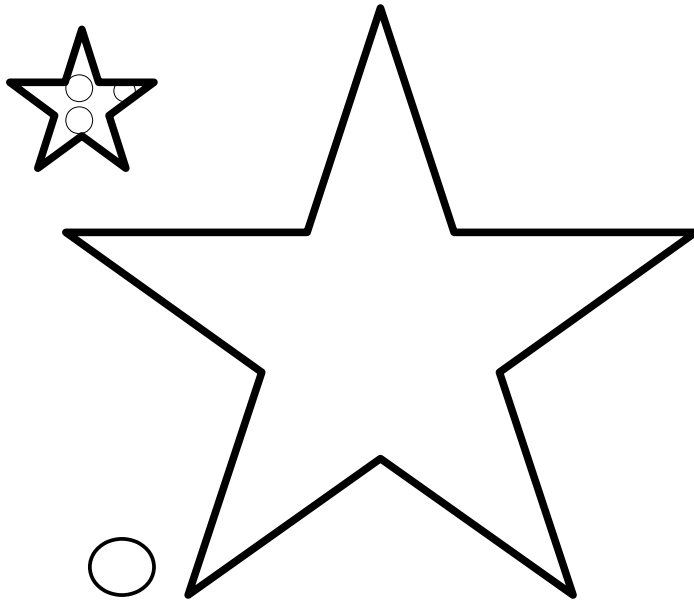

Validation : 

Commentaire : _____

Compétence : Reconnaître plus que - moins que.

Consigne : 1- Colle une gommette sur la planète qui a le moins d'étoiles.
2- Colle une gommette sur la planète qui a le plus d'étoiles.

1



2



Validation :



Commentaire :

Compétence : Reconnaître autant que.

Consigne : Colle autant de gommettes qu'il y a d'étoiles sur la première planète.

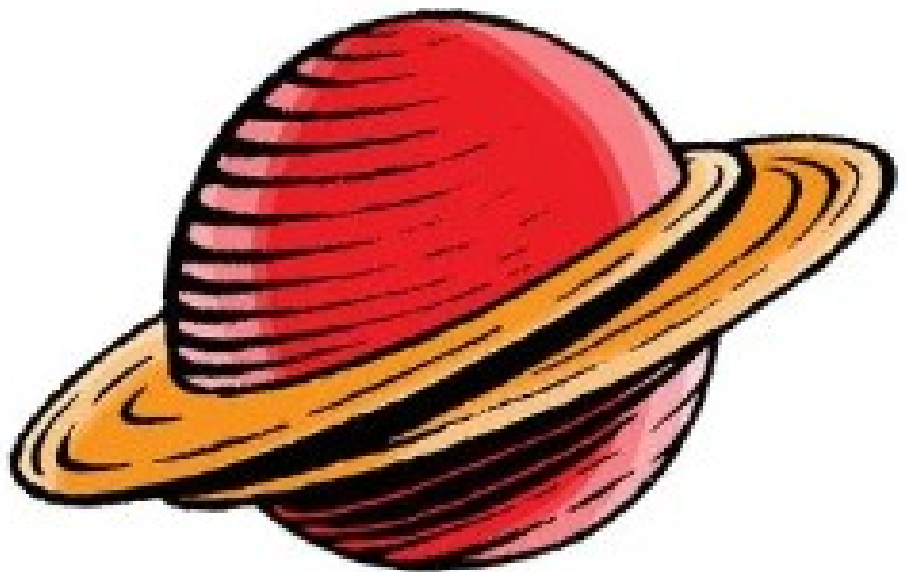

Validation : 

Commentaire : _____

Compétence : Réciter la comptine numérique jusqu'à ... (Cette compétence est un bilan des acquis, elle ne sera validée qu'au semestre 2).

Consigne : Récite la comptine la plus loin possible et sans aide.

1 2 3 4 5 6 7

8 9 10 11 12 13 14

15 16 17 18 19 20

Validation :



Commentaire :

Compétence : Dénombrer une collection jusqu'à ... (Cette compétence est un bilan des acquis, elle ne sera validée qu'au semestre 2).

Consigne : Compte le nombre d'étoiles dans chaque sac.

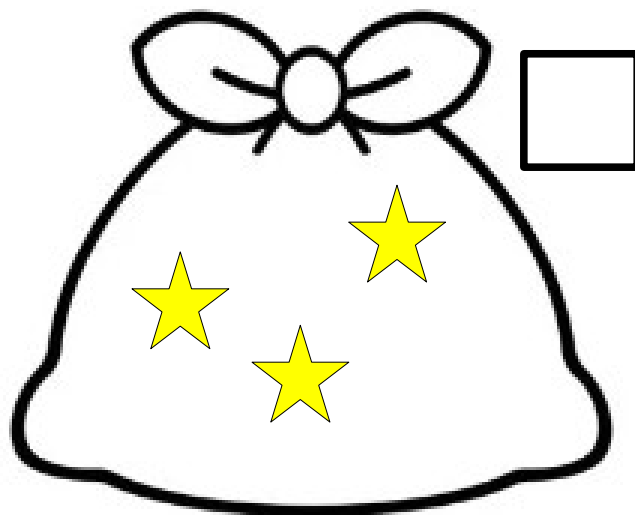

Validation :



Commentaire :

Compétence : Annoncer le nombre de doigts, les constellations jusqu'à ...
(Cette compétence est un bilan des acquis, elle ne sera validée qu'au semestre 2 et sans dénombrer).

Consigne : Donner le nombre représenté.

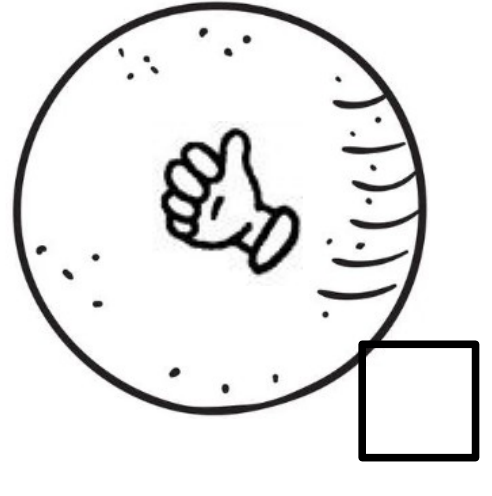
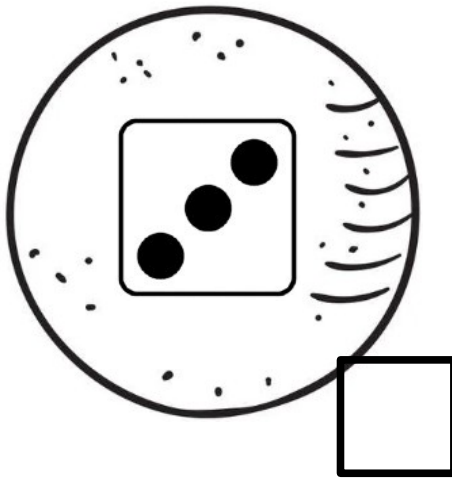
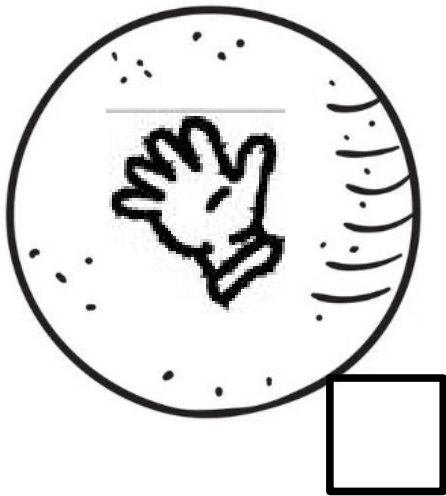
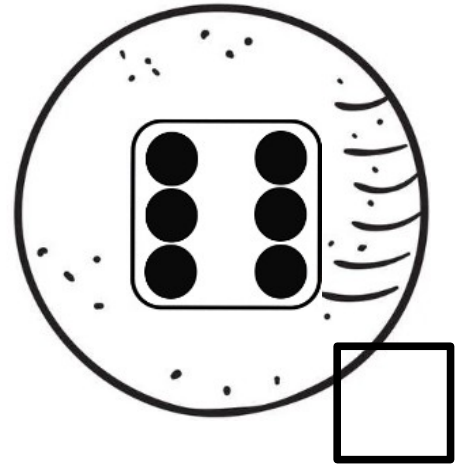
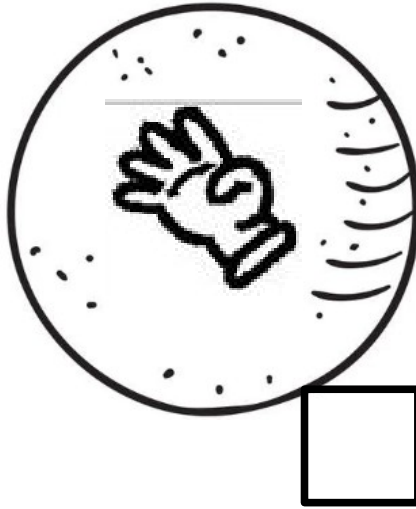
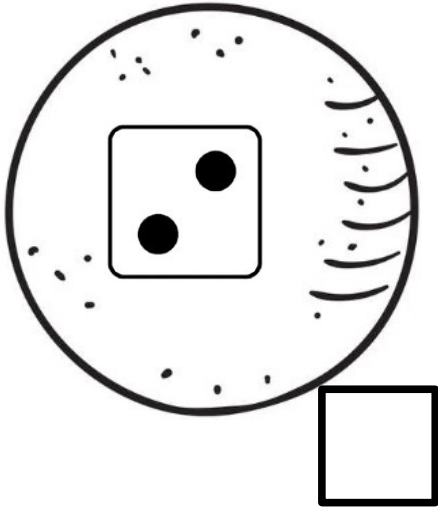

Validation : 

Commentaire : _____

Compétence : Lire les nombres jusqu'à ... (Cette compétence est un bilan des acquis, elle ne sera validée qu'au semestre 2 et sans dénombrer).

Consigne : Donner oralement le nombre écrit.

3

2

1

4

6

1

2

5

4

3

6

8

Validation :



Commentaire :

Compétences : Reconnaître et nommer les formes.

Consigne : Coller les formes correspondantes et les nommer.

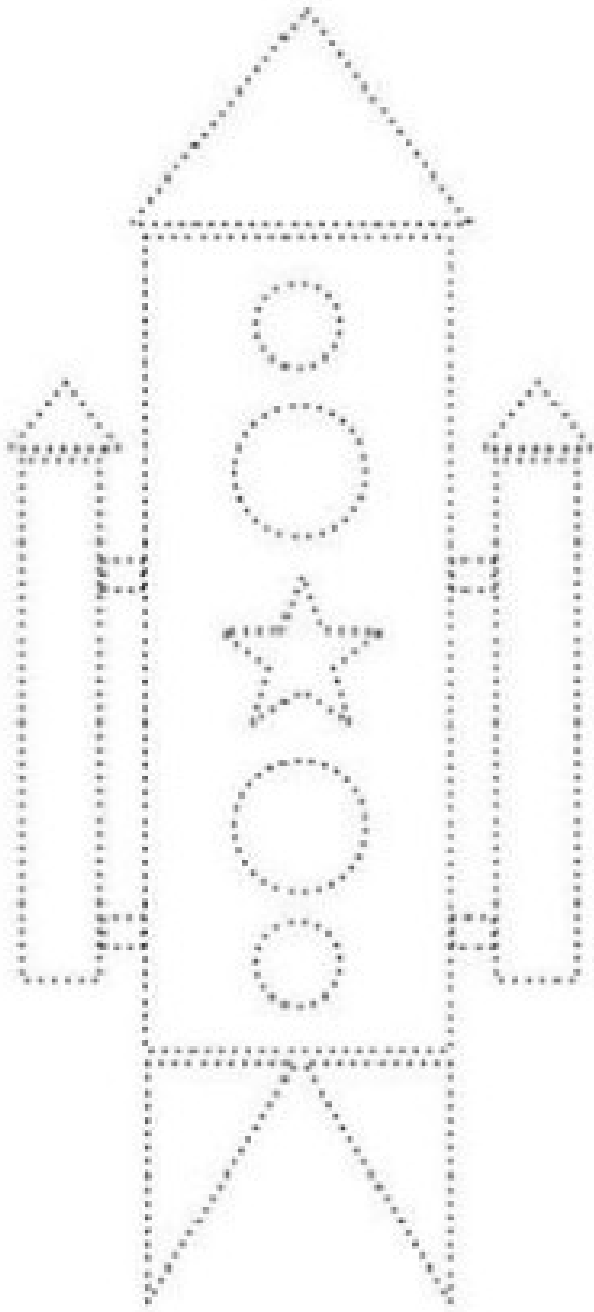

Rond.

Triangle.

Carré.

Rectangle.

Validation : 

Commentaire : _____

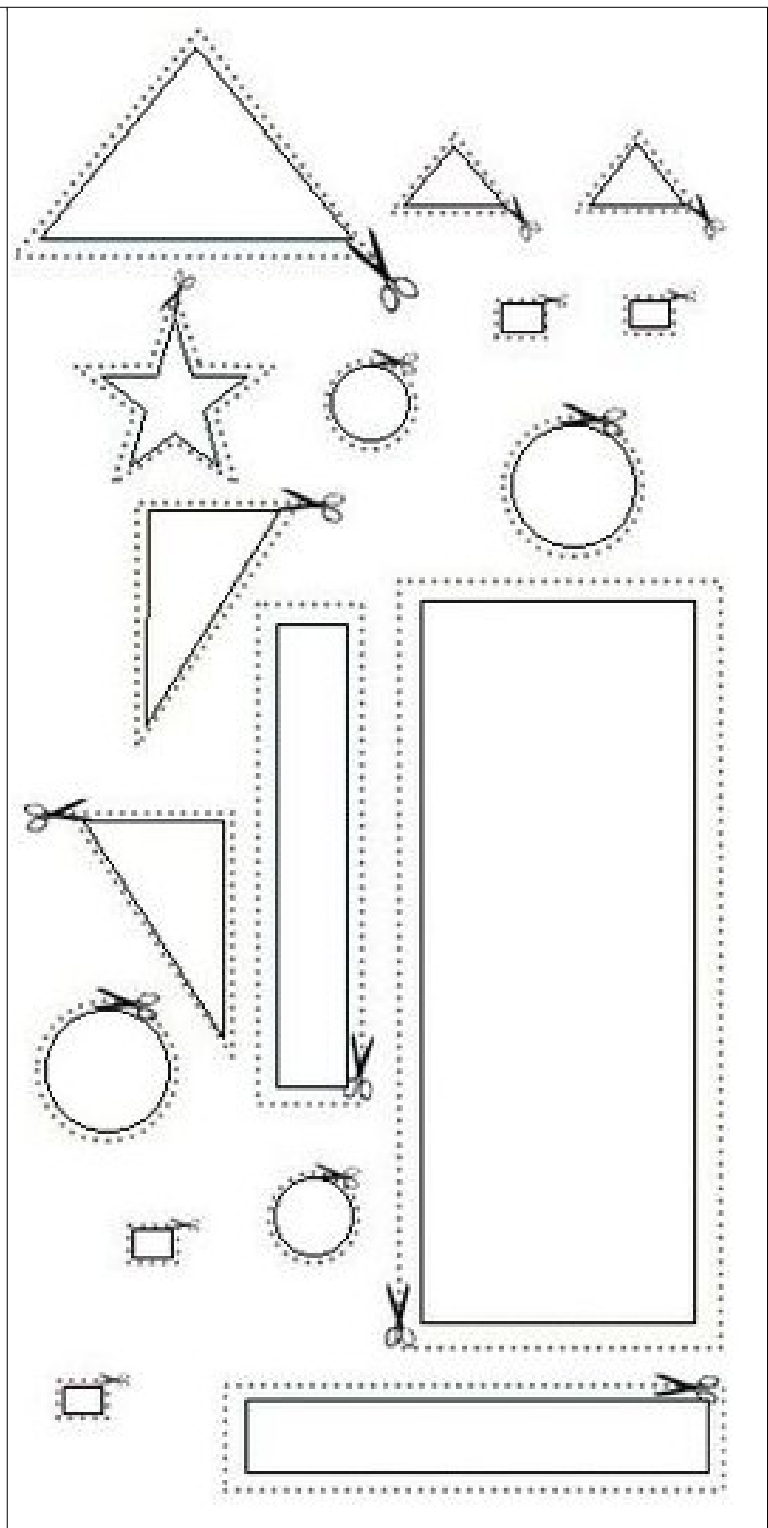
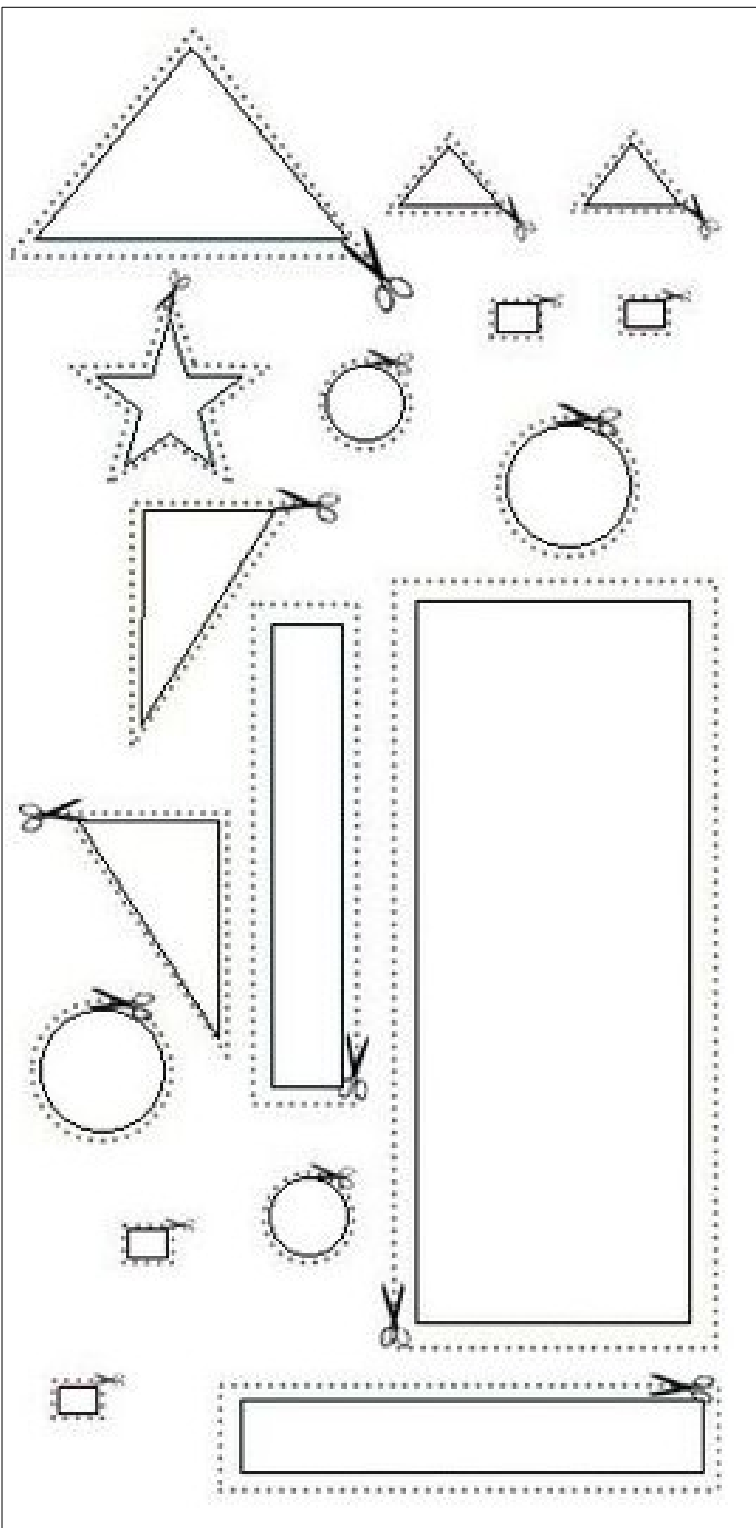

Compétence : Ranger selon 5 tailles. (Cette compétence est un bilan des acquis, elle ne sera validée qu'au semestre 2).

Consigne : Colle les fusées de la plus petite à la plus grande.

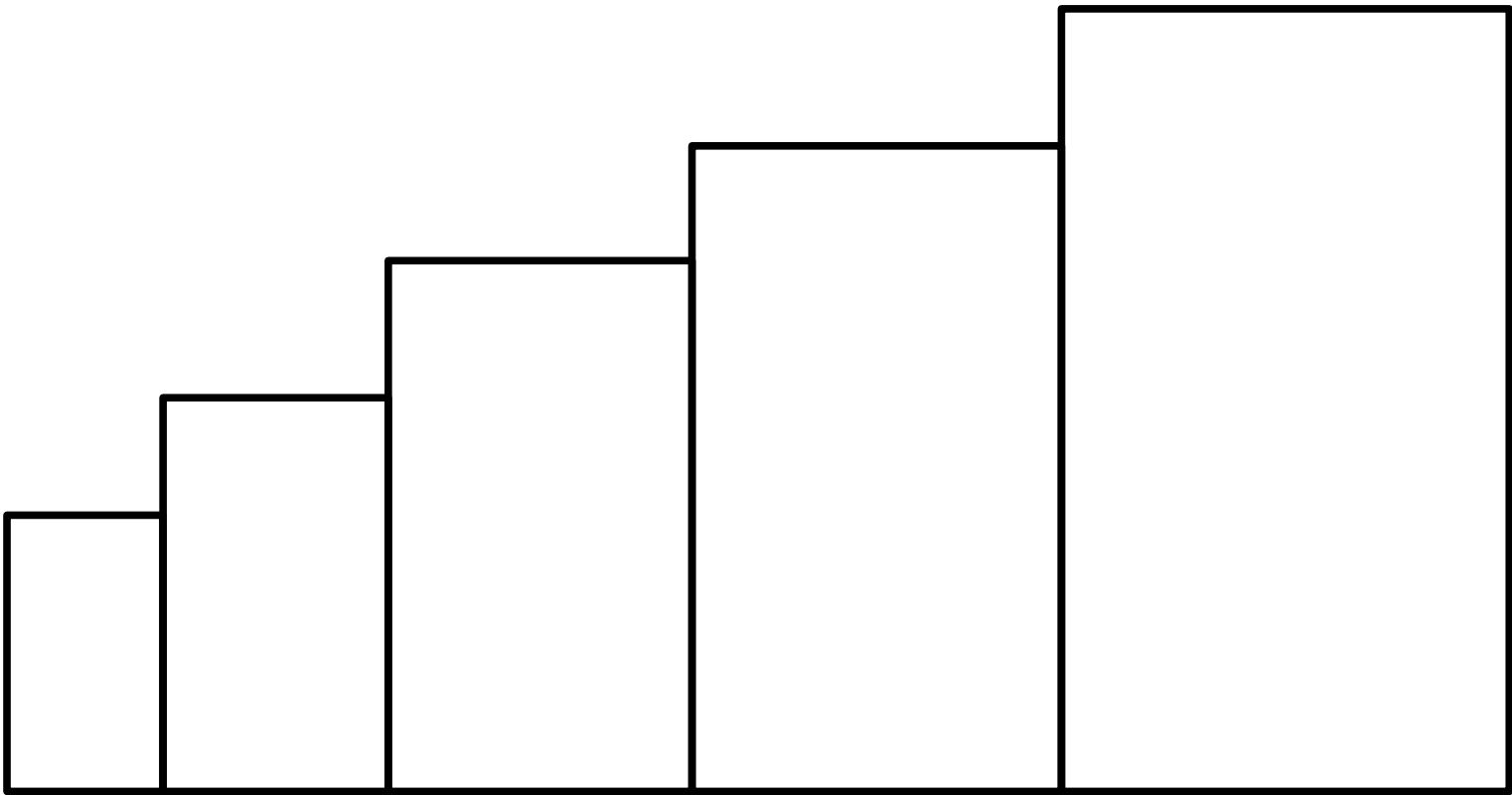

Validation :



Commentaire :

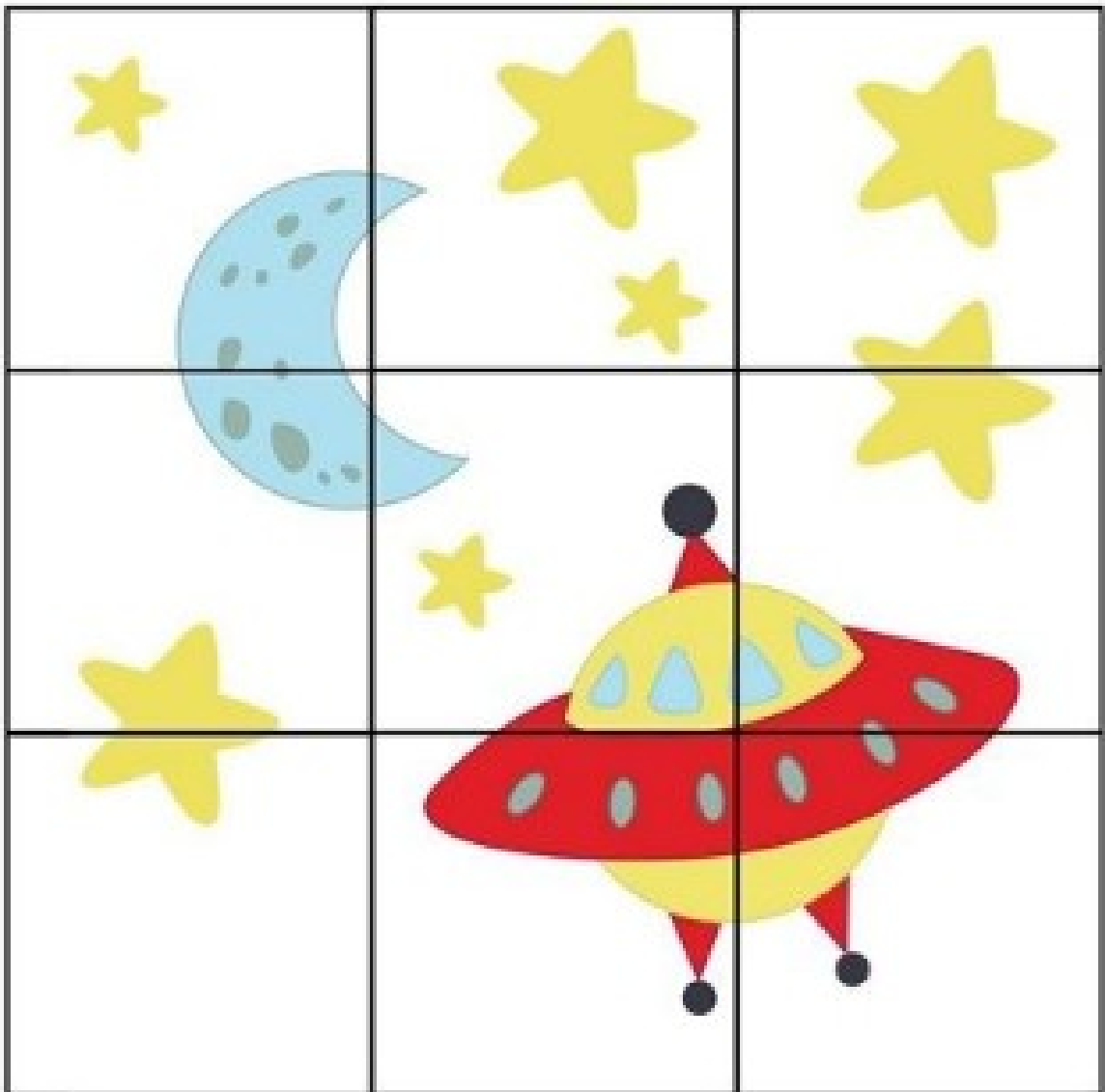
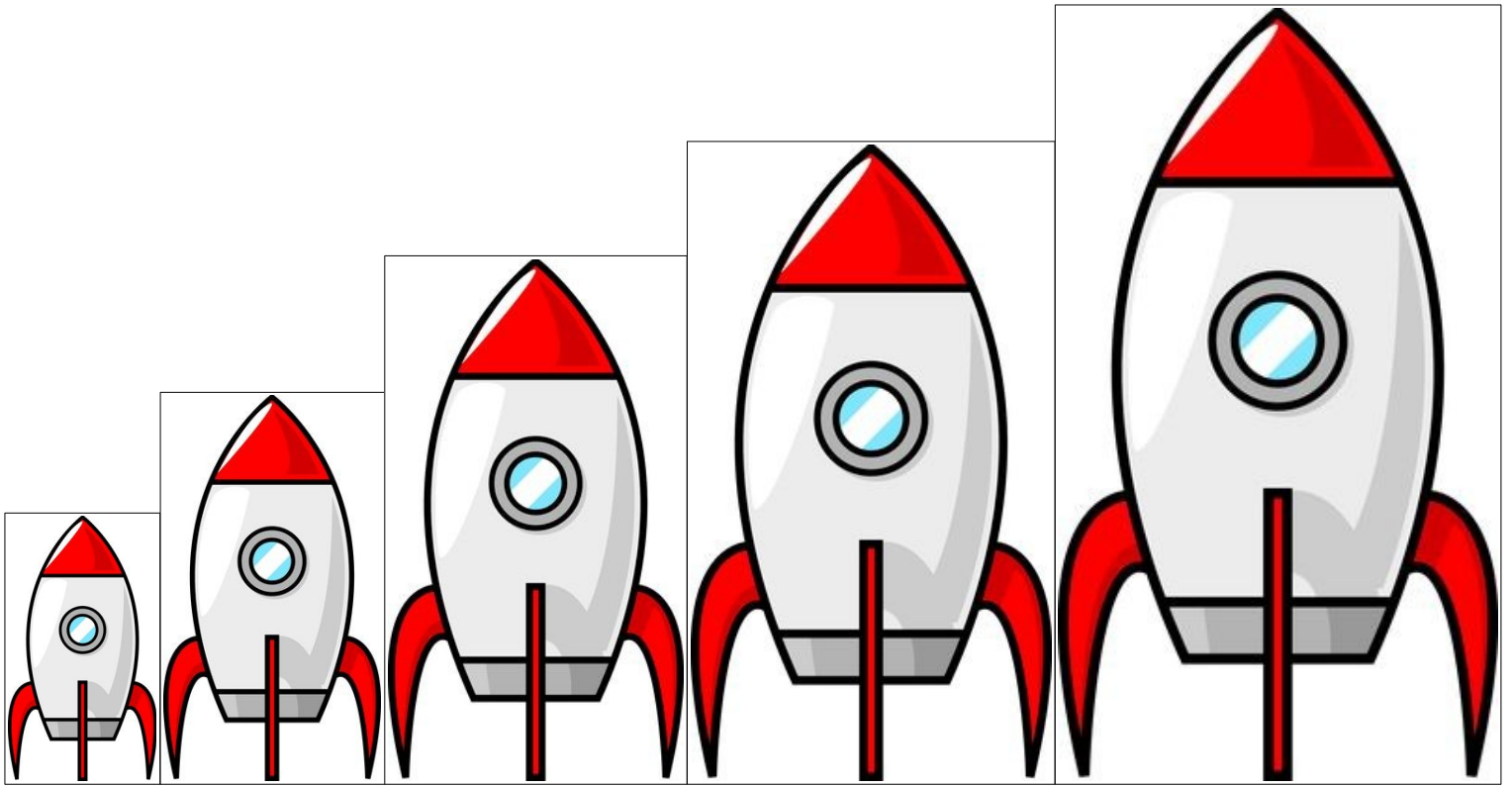

Compétence : Réaliser un puzzle de 9 pièces sans modèle. (Cette compétence est un bilan des acquis, elle ne sera validée qu'au semestre 2).

Consigne : Colle les pièces du puzzle au bon endroit.

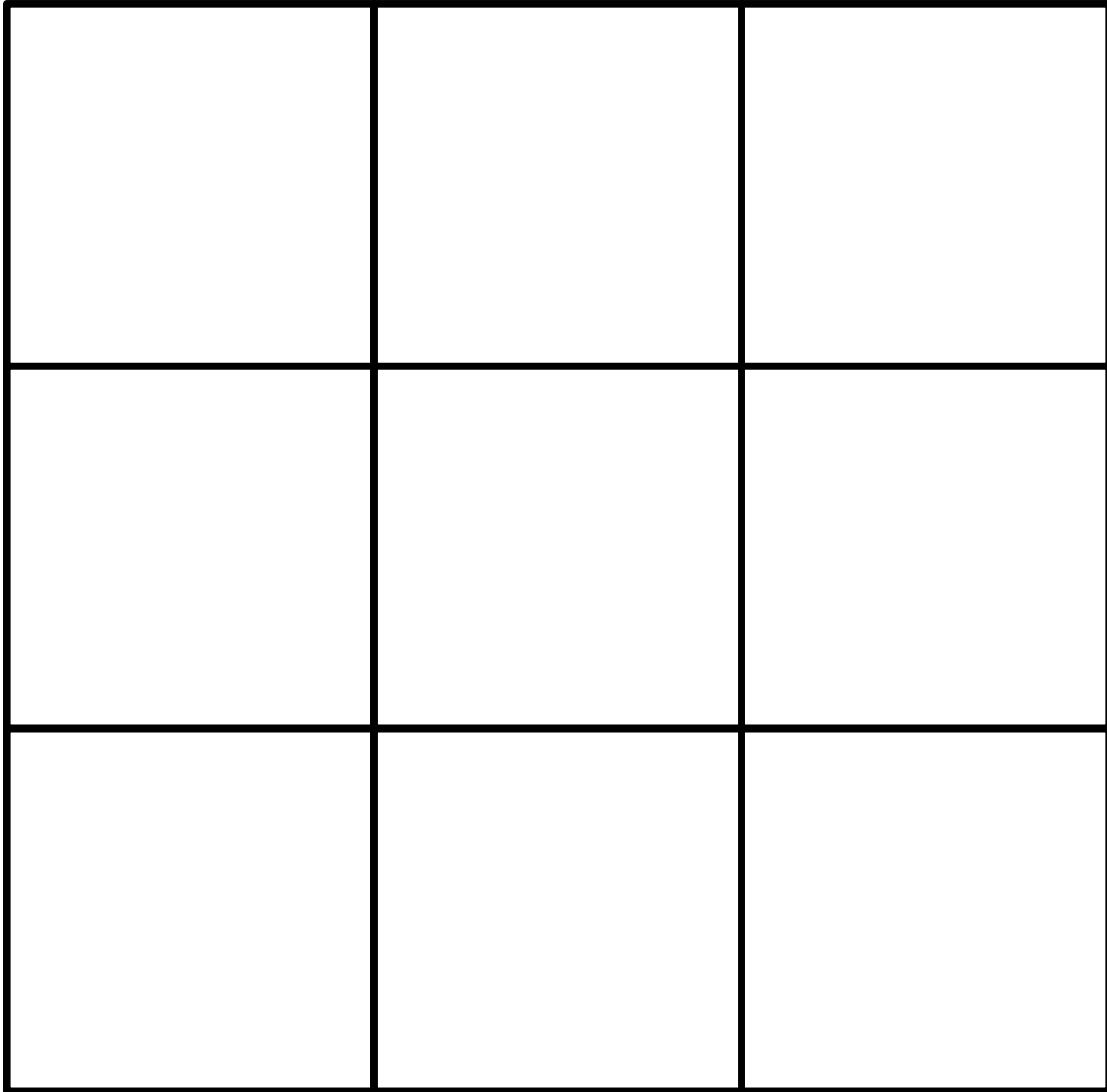

Validation : 

Commentaire : _____

Compétence : Réaliser un algorithme 1-1. (Cette compétence est un bilan des acquis, elle ne sera validée qu'au semestre 2).

Consigne : Colorie les étoiles en alternant le jaune et le bleu.

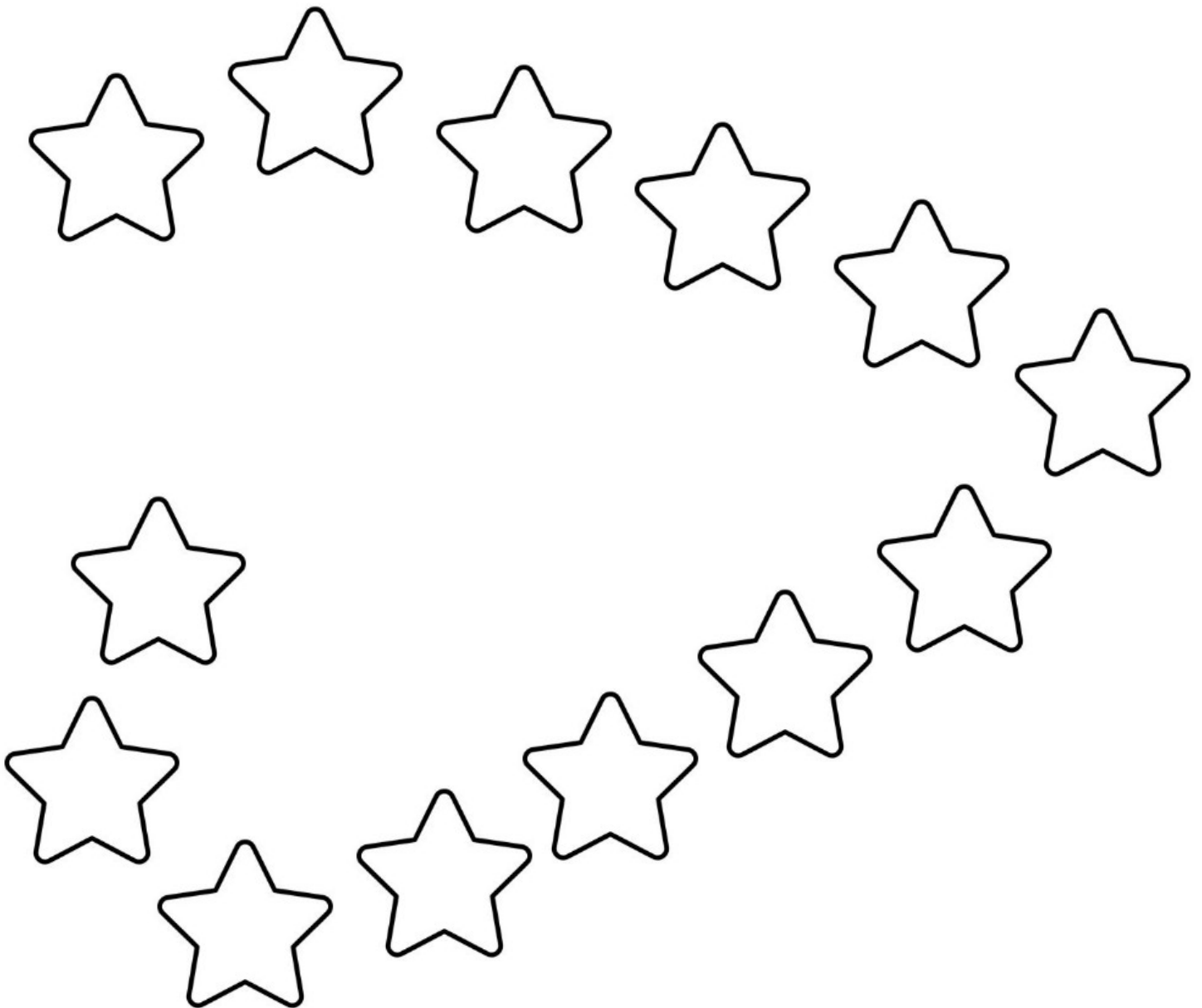

Validation : 

Commentaire : _____

Compétence : Dire sa position dans l'espace.

Consigne : Dire où se situe l'astronaute.



A côté



Au dessus



En dessous



Le chien est en 1^e.

Le chat est en 2^e.

Validation : 

Commentaire : _____

Compétence : Ordonner les moments de la journée.

Consigne : Colle les images dans l'ordre chronologique.

| | | | |
|---------|-----------|-----------|---------|
| | | | |
| Accueil | Motricité | Activités | Cantine |

Validation : 

Commentaire : _____

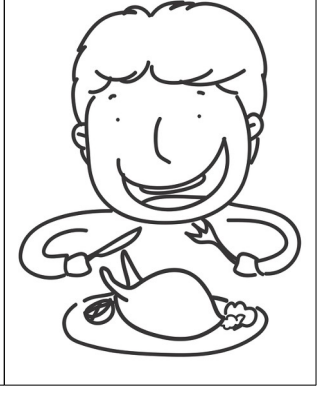
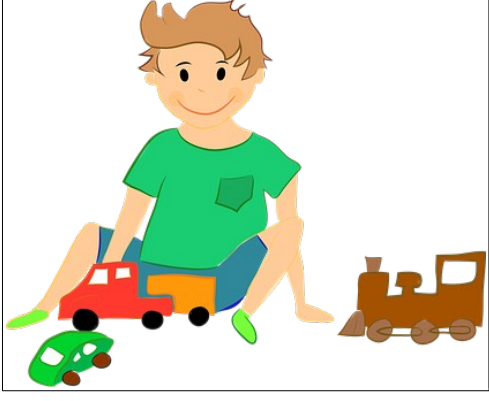
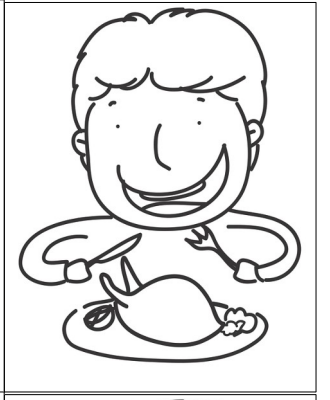
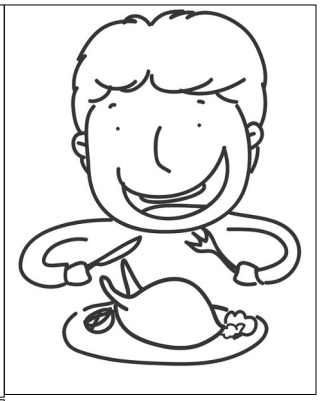

Compétence : Ordonner 3 images séquentielles. (Cette compétence est un bilan des acquis, elle ne sera validée qu'au semestre 2).

Consigne : Colle les images dans l'ordre chronologique.

| | | | | |
|--|--|--|--|--|
| | | | | |
|--|--|--|--|--|

Validation :



Commentaire :

